

# Final report

## 1. Project details

<b>Project title</b>	HFC Marine
<b>File no.</b>	64018-0721
<b>Name of the funding scheme</b>	EUDP
<b>Project managing company / institution</b>	Ballard Power Systems Europe (BPSE)
<b>CVR number</b> (central business register)	30804996
<b>Project partners</b>	Aarhus University (AU), Hvide Sande Shipyard (HVSA), Maritime Cluster Funen (MCF), Odense Maritime Technology A/S (OMT)
<b>Submission date</b>	05 April 2022

## 2. Summary

The HFC Marine project explored the feasibility of using marine fuel cells in marine environments with a focus on hydrogen safety and certification, fuel cell cooling, air compression, installation integration and cost of ownership. A test bench and a 200kW concept module were built in a test lab environment to run simulations. The HFC Marine project activities have been vital for us to uncover the market realities and expectations from the project stakeholders in order to uncover the detailed requirements for the function of a hydrogen fuel cell module for the marine market. We have explored smaller vessel parameters, power management requirements for fuel cell driven vessels and made large strides in the push to certify the fuel cell as a power source. All results will be integrated into the continued development and integration of the fuel cell into varied marine vessels.

Projektet HFC Marine har undersøgt muligheden for at bruge brændselsceller til maritime applikationer i et maritimt miljø. Projektet har fokuseret på sikkerhed og certificering, køling af brændselsceller, luftkomprimering, samt installation og ejerskab. Projektet har udviklet et første 200kW konceptmodul og en testbænk til moduler i 200kW størrelsen og blev brugt til at køre forskellige simuleringer. Projektaktiviteterne i HFC Marine har været afgørende i at afdække markedrealiteterne og forventningerne fra projektets interessenter samt afdække de detaljerede krav til funktionen af et brintbrændselscellemodul til det marine marked. Konsortiet har undersøgt mindre skibsparmetre, krav til strømstyring for brændselscelle drevne maritime applikationer og gjort store fremskridt med at certificere brændselscellen som en strømkilde. Alle resultater vil blive integreret i den fortsatte udvikling og integration af brændselscellen i forskellige marinefartøjer.

## 3. Project objectives

The objective of the project was to take the first important steps towards a fully fuel cell electric ship design that meets customer requirements in power, range, speed, reliability, operability, payload, weight and cost. These first steps comprise the conceptual design of the battery-fuel cell system, mapping the maritime challenges and aligning with certification bodies and industry standards. They also include the development of maritime specific safety features, controls and development of ambient protection devices for the fuel cell system in order to prevent salty air or water to contaminate the fuel cell. The battery-fuel cell propulsion system will be adapted and prepared for maritime application with respect to re-fuelling, operation at sea and in harbour, incl. maritime specific service and maintenance.

## 4. Project implementation

The project began in Q3 2018. It began with a clear plan to develop and test the newest generation of hydrogen fuel cell technology. We worked with the members of the consortium to understand the ship specification needs, risks and safety, and the challenges of implementing the technology into an existing market. The biggest risks we encountered over the life of the project had to do with the challenges of certifications and integration activities for a very new technology that has a limited history. The project developed as expected with the creation and submission of deliverables on schedule. The global COVID 19 pandemic caused some problems and there was an approved 3-month extension of the project in 2020.

## 5. Project results

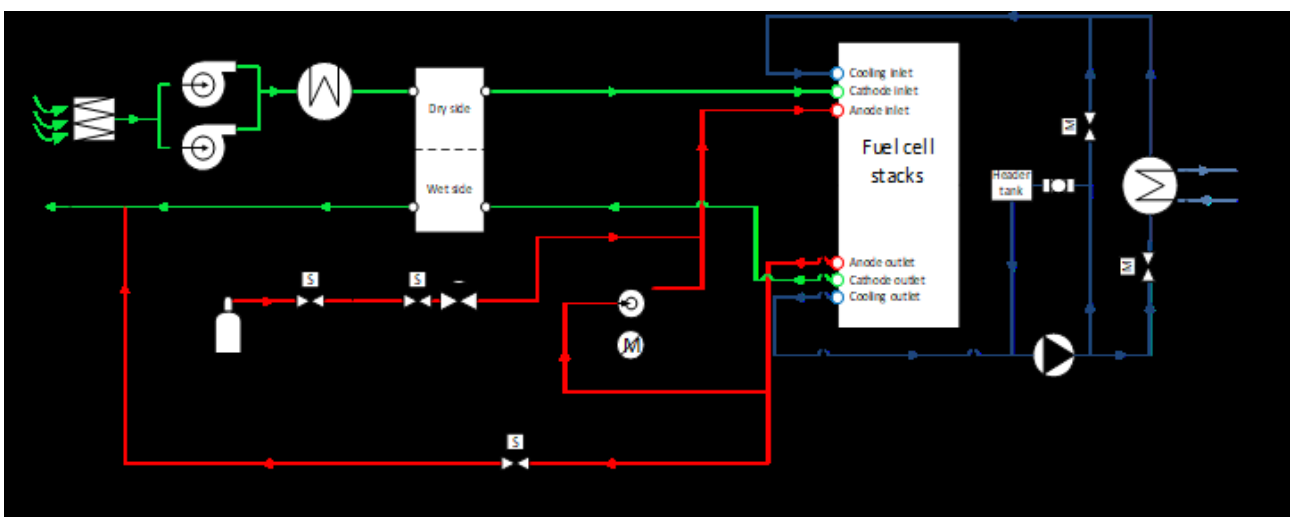

Figure 1. System Description

The original objective of the project, to develop necessary preconditions to prepare the hydrogen fuel cell technology to operate in the maritime environment, was obtained.

Work Package (WP) 2 was a close collaboration with OMT as they provided a ship design with which BPSE was able to extrapolate, using software, the required kW and battery size to run the theoretical vessel. This laid the groundwork for WP 3 and the work AU did with power electronics and safety. BPSE built and maintained a test bench for this project to verify hypotheses and software operability. Moving into WP4, BPSE investigated the air cleaning and compressor unit. Investigations centered around the necessary parameters and available materials to complete an air and compressor system that could support the work inside the fuel cell. WP5 was the investigation of the possibility of the development of a sea water cooling system. This was shelved rather quickly as it became clear that any sort of filtration system small enough to filter out sea life would inhibit the flow of water to the point where it became moot. WP6 opened up the hydrogen requirement and availability study and a comprehensive report was submitted on the mapping of H<sub>2</sub> providers. WP7 focused on the test bench and its capabilities to provide lab-based data to prove or disprove the designs efficacies and feasibilities. Each WP built on the discoveries and work of the previous WPs and brought a fuller picture of the future of the hydrogen fuel cell in marine environments.

OMT has contributed to the project with a detailed investigation of how a hydrogen-based fuel cell operated propulsion system can be installed in a new design of a typical diesel-electric driven minor domestic ferry. This included an analysis of the complete system-design of the hydrogen powering solution, including the storage, bunkering, transporting, venting etc. installations. An electric load balance and a high-level electric design, including requirements for battery capacity has been established. Further a number of overall safety aspects has been discussed, including vessel and passenger safety, fire detection and extinguishing, hazardous area definitions etc. The overall conclusion is that hydrogen powered fuel-cell solutions are technical feasible for coastal ferries and smaller ferries.

A Total Cost of Ownership for the operation of the vessel on a typical Danish ferry route has been made. The overall conclusion based on the TCO analysis, is that the hydrogen fuel technology in general is capable of fulfilling the requirements for propulsion and power for the selected vessel. However, the CAPEX indicates a considerable larger installation cost compared to the diesel-electric setup. For the specific case, CAPEX of the comparable machinery installation was around three times higher than hybrid diesel-electric propulsion, when considering today's cost of fuel cells and associated equipment. In both cases a battery installation will be required, ie. to handle peak loads in the propulsion system.

Looking at the OPEX, the FC/battery installation may require additional maintenance and service, but the largest cost driver is currently the hydrogen fuel price, which roughly is ten times higher than for marine diesel. Considering that the cost of hydrogen is expected to decrease significantly during the coming years, due to large ongoing and upcoming investments in production of "green hydrogen", hydrogen fuel-cell power solutions are likely to become a good technical and commercially solution for zero-carbon emission coastal vessels.

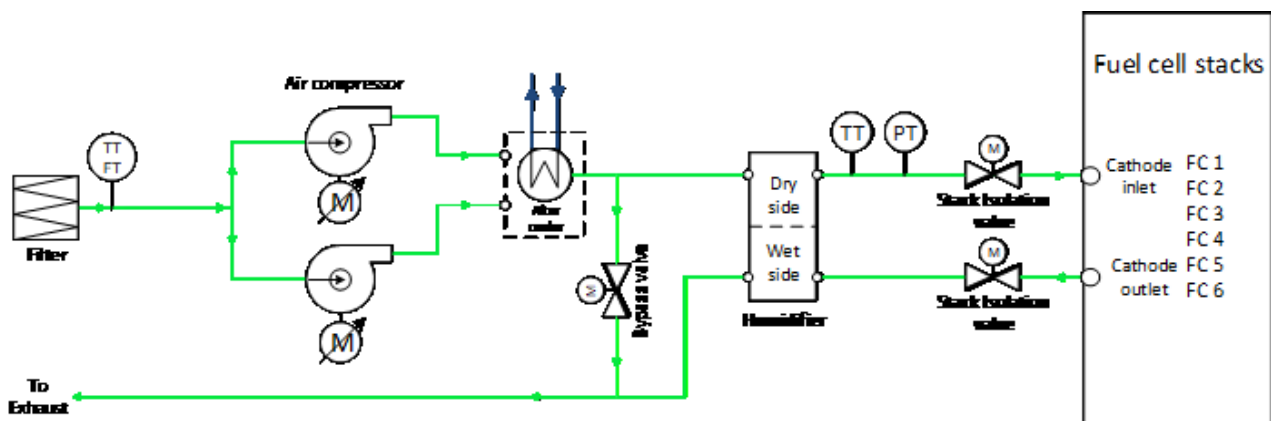

*Figure 2. Air System Schematic*

The technological results obtained included an adapted cooling system design to mesh with existing onboard cooling systems, an outline and concept of air quality measuring systems (a 2 stage air quality cleaning and salt removal system), electrical integration of systems into ships using existing battery and hybrid know how, and advancement of the knowledge base of this new technology with leading certification bodies. The certification process for the next generation fuel cell is well underway due to the work done under this project.

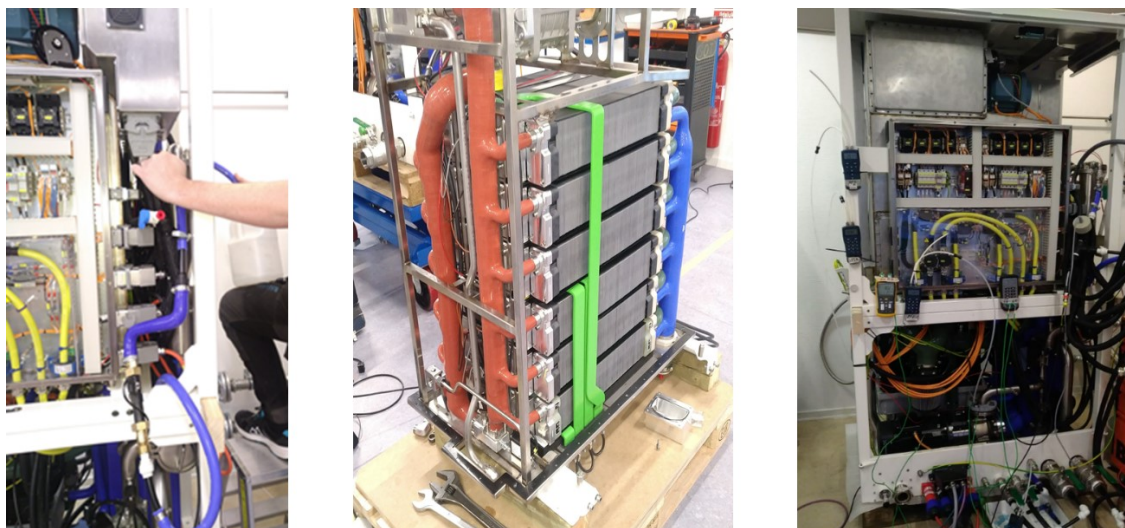

*Figure 3. Fuel cell stacks and module in test setup*

The target group for this project is mainly the shipping and marine commuter industry as the expectations for reduction of carbon emissions continue to grow and clean energy solutions are expected to become the preferred choice for vessels operating in the target geographical area.

The feasibility study verified/validated hydrogen fuel cells as a feasible propulsion/power management system for marine application. However, hydrogen fuel cells face some limitations especially high CAPEX due to the early-stage development of hydrogen fuel cells and lack of hydrogen infrastructure. Fuel cells can be an future attractive technology for especially ferries, inland water vessels and offshore support ships and crew transfer vessels.

Hydrogen, when produced from renewable sources, is a clean fuel with no emissions of SoX, NoX and particle matters.

Fuel Cells has an electrical efficiency off about 60%. Hydrogen is a feasible clean fuel, but some limitations must be overcome especially regarding bunkering infrastructure. Another challenge of hydrogen compared to MDO is its low volumetric and gravimetric density, which means that vessels will have to carry larger fuel tanks than compared to a vessel with a regular marine engine running on MDO.

Regulations for maritime application of hydrogen fuel cells are still missing. For the time being, fuel cell systems must be approved using the IFG Code for alternative design and the hydrogen system onboard ships must be approved following the MSC.1 Circ. 1455.

Link to published articles: [https://pure.au.dk/portal/en/persons/jalil-boudjadar\(1d003dbe-9d0a-42ec-a90a-106e4253b056\)/publications.html](https://pure.au.dk/portal/en/persons/jalil-boudjadar(1d003dbe-9d0a-42ec-a90a-106e4253b056)/publications.html)

## Summary of WP results and work

### WP1. Project Management, BPSE

The project management went as planned during the project with half year consortium meetings being held and yearly reports being submitted as well as the quarterly financial reporting.



*Meeting in Hvide Sande 15.10.2019: tour of electrical ferry under construction*

For the dissemination an article was released on the 20 May 2019: [New project to prepare hydrogen fuel cells for maritime application \(hvsa.dk\)](https://www.hvsa.dk). The project and its results were also mentioned during presentations at several conferences in Denmark and abroad including:

Event	Presentation	Date	Place
Developing Hydrogen Ports and Maritime Policy in The North Sea Region	Kristina Fløche Juelsgaard	26. March 2019	Scotland
Brintbranchens års dag	Kristina Fløche Juelsgaard	10. April 2019	Denmark
Den danske brint- og brændselscelledag.	Søren Winther Nielsen	19. November 2019	Denmark
Skagerak Business Summit 2019	Kristina Fløche Juelsgaard	12. November 2019	Denmark
PtX I tung Transport Conference	Kristina Fløche Juelsgaard	29. Oktober 2020	Denmark
SEA Europe Maritime Fund working group	Kristina Fløche Juelsgaard	16. November 2020	Belgium
Decarbonizing Esbjerg Port	Kristina Fløche Juelsgaard	27. November 2020	Denmark
Power-2-Mobility Conference, COWI	Kristina Fløche Juelsgaard	1 December 2020	Denmark

Maritime Hybrid Electric & Fuel cell Conference	Kristina Juelsgaard	Fløche	7-8 December 2020	Norway
---	---------------------	--------	-------------------	--------

All deliverables and objectives in WP1 were met and achieved during the project.

## WP2. Specifying ship solution, OMT

The work in WP2 was done in a close collaboration between Ballard, OMT and HAS and included the specification of the modular ferry, propulsion system, test procedure and certification requirements. The results and findings included determining the power requirements of a hybrid fuel cell electric ferry to support the development of the 200-kW fuel cell and prepare for an eventual demonstration of a fully operational hydrogen and fuel cell electric ferry in Denmark. The work also laid the foundation of the work of getting BPSEs 200-kW FC-Wave product type approved for maritime usage. This is a process that is still ongoing with the type approval expected to be obtained during 2021.

The work resulted in a report and spread sheet data summary and a high-level arrangement drawing as guides for the other WPs.

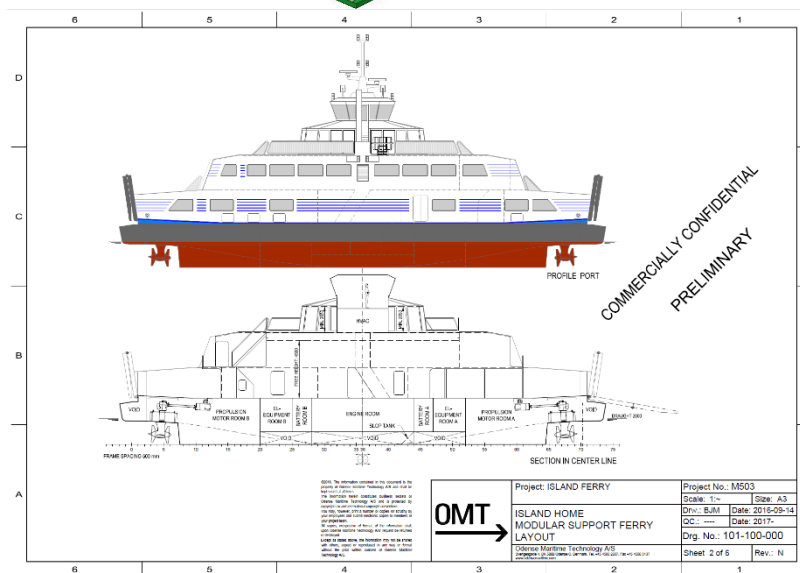
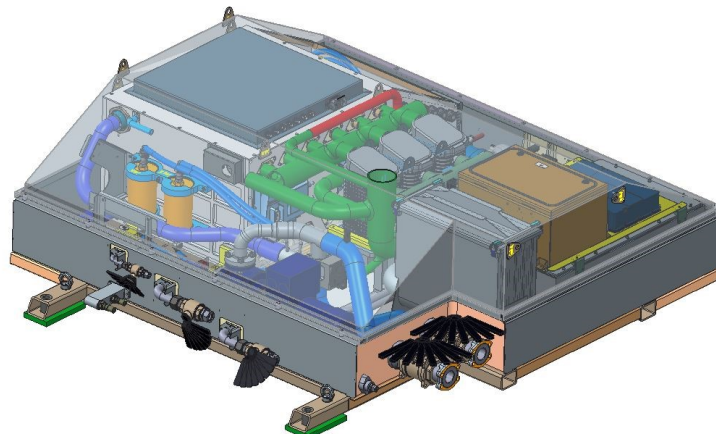

*Preliminary Design of ferry and maritime fuel cell*

In the end several changes were made to the preliminary fuel cell design most visibly the system is now standing up instead of laying down.



*Final design 200 kW module*

All deliverables and objectives in WP 2 were met and achieved during the project.

### **WP3. Power Electronic and safety, AU**

In this WP AU, BPSE, HVSA and OMT jointly worked on power electronic and safety aspects of the hybrid fuel cell electric propulsion system. A report documenting the safety considerations of risk assessment study and test results was developed.

Under the WP the AU team has developed a simulation model including the different functions of both FC and battery. Different devices have been considered as well to make the models realistic. The team also developed a safety-driven energy scheduling algorithm, which considers actual energy cost, safety (high temperature, over-charge and -discharge) and resource availability. Such an algorithm has been successfully tested on artificial data (for publication purposes) and actual data from HVSA.

BPSE built and maintained a test bench for this project to verify hypotheses and software operability.

All deliverables and objectives in WP 3 were met and achieved during the project.

### **WP4 Develop air system, BPSE.**

The work in WP 4 was centred around the development of an air system to control and secure the right air quality for the fuel cells to achieve high lifetime and efficiency. A specification of the air system requirements was made and sent to the air system/filter manufacturer. Several systems were identified as suitable and has later been verified during test. An air system was found and integrated into the fuel cell module.

All deliverables and objectives in WP 4 were met and achieved during the project.

### **WP5 Sea water cooling, BPSE**

WP 5 included the investigation of the possibility of the development of a sea water cooling system. As specified earlier in the report this work was abandoned after initial investigations. But the consortium did discover/discuss the opportunity of using the waste heat generated from the fuel cell during operation. This has led to Ballard including these initial thoughts in its test setup at their lab in Hobro supplying the waste heat from the test of the fuel cells to the local heating district to the benefit of the local residents in Hobro and giving insight into how this could be done at a ship, see illustration under WP7 description.

No deliverables and objectives in WP 5 were met and achieved during the project.

### **WP6 On-board hydrogen storage BPSE**

The work in this WP was centered around investigating the different options for H<sub>2</sub> supply for maritime applications and provide a recommendation on the preferred option. The results of this investigation were summarized in a comprehensive report that included investigations into onboard hydrogen requirements, certification requirements for hydrogen onboard, Commercially Available (or Near Commercial) for Onboard Storage and Mapping and Comparison of H<sub>2</sub> Storage Suppliers.

All deliverables and objectives in WP 6 were met and achieved during the project.

### **WP7 Integration and test, BPSE**

The objective of WP7 was to provide a scaled down lab test version of the required propulsion system. The test of any high-power generating technology is demanding for the test equipment, and PEMFC is no exception. Therefore, a sustainable testing platform for the 200 kW system was developed. The system enabled the utilization of electrical and thermal energy, converted during tests. This is done through a large thermal buffer (in the form of a 4.000 m<sup>3</sup> accumulation tank), which is connected to the district heating network of Hobro.

The modules are rated at 200kW electrical power, with approximately 300 kW thermal energy from primary cooling. This means that Ballard is supplying, in excess of 500 kW high-quality thermal energy, during testing. Which is then used to heat up houses in the city, or stored for future use.

In addition to the environmental benefits of this setup, it is also a state-of-the-art development platform for prototype-testing new PEMFC systems for marine and maritime solutions. It is capable of testing the systems in all operational conditions to ensure that the modules provided by BPSE are high performance and impeccable reliability.



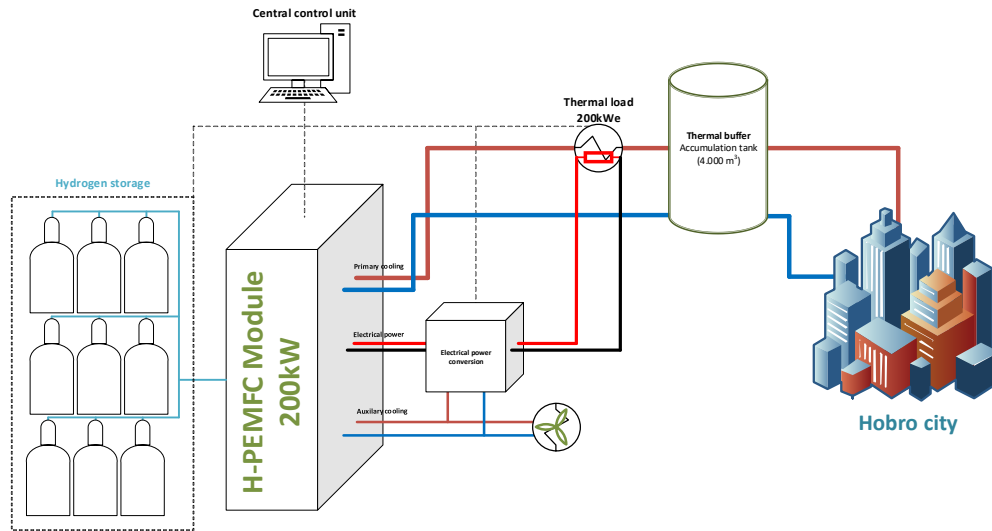

*200 kW Hydrogen PEM Fuel Cell (PEMFC) test setup*

The individual subsystems were tested in this setup giving valuable data for future real life demonstration projects as well as the certification of the module.

All deliverables and objectives in WP 7 were met and achieved during the project.

### **WP8 Feasibility study MCF**

WP8 set out to Investigate whether hydrogen fuel cell (HFC) is to be consider as a viable technology for zero emission vessels. Identifying barriers and advantages from a market, technical, economic and legal point of view.

BPSE provided into to the legal study benefitting from their ongoing relation and meetings with classification society of DNV GL.



*DNV GL and Ballard Europe kickoff meeting*

The feasibility study verified/validated hydrogen fuel cells as a feasible propulsion/power management system for marine application. However, hydrogen fuel cells face some limitations especially high CAPEX due to the

early-stage development of hydrogen fuel cells and lack of hydrogen infrastructure. Fuel cells can be an future attractive technology for especially ferries, inland water vessels and offshore support ships and crew transfer vessels.

All deliverables and objectives in WP 8 were met and achieved during the project.

### **Summary of Technical and Commercial Milestones:**

1. *MS1 Specification reported. Responsible OMT – M7 (Achieved)*  
WP2 finished with report and spread sheet data summary and high-level arrangement drawing.
  
2. *MS2 Safety reported. Responsible AU – M19 (Achieved)*  
WP3 finished with report documenting the safety considerations of risk assessment study
  
3. *MS3 Air cleaning system. Responsible BPSE – M17 (Achieved)*  
WP4 Developed air system constructed and tested
  
4. *MS4 Cooling system. Responsible BPSE – M17 (Abandoned)*  
WP5 Task 5.2 complete a recommendation for a cooling solution for next steps
  
5. *MS5 Comparative study on on-board hydrogen solution. Responsible BPSE – M24 (Achieved)*  
WP5 finished with report documenting the comparative study
  
6. *MS6 Lab test system complete and ready for test. Responsible BPSE – M20 (Achieved)*  
WP 7 task 7.2 finished with a picture documentation of the test bench system
  
7. *MS7 Project finished, Responsible BPSE – M25 (Achieved)*  
Final report incl. relevant test results completed

### **Commercial milestones:**

8. *CM1 Feasibility report. Responsible MCF – M24 (Achieved)*  
WP8 Feasibility report and guideline for implementation of HFC in marine environments

## 6. Utilisation of project results

The technological results of this project will first be used in the small commuter ferry industry in and around Scandinavia and Northern Europe. As the technology matures, it has potential to spread into larger marine applications, including longer haul ferries and cargo shipping. Within Ballard, these results will act as a springboard for the continued development of the latest generation of fuel cells. In the LH2 Vessel project where several of the partners in , the results will support the following activities:

- System modelling and control (hybrid systems with batteries and fuel cells to meet operational load profile) and define the modular approach with required redundancy (system control adaption to meet redundancy requirement and fuel cell operational optimum)
- Design module interfaces and concept of coupling multiple modules and packaging strategies (develop module stacking best practice for larger power outputs, from 200 kW to 1.2 MW with the same building blocks and optimize packaging of modules to enable service and maintenance access and replaceability)
- Design a Liquid Hydrogen storage system for maritime solutions with special focus on energy efficiency and fuel consumption. Design concepts for optimal fuel consumption from liquid hydrogen storage for improved energy efficiency and better fuel (Hydrogen) economy. This will include hydrogen pressure considerations and safety evaluations.
- Design air supply system for salty environment (bring learnings from HFC Marine)

The development work in LH2 Vessel will also to a large extent use the test bench facilities from the HFC Marine activities.

The two projects HySeas III and Flagships will also demonstrate the use of hydrogen fuel cells for zero emission ferry services. In both projects the usage of gaseous hydrogen or liquid hydrogen will be discussed, making it clear that the fuel cell modules for maritime need to prepare for both types of fuel. HFC Marine will provide the underpinning of these explorations as well.



*Figure 4 Flagships push boat.*

### Competition and market

The shipping industry is currently at the early stage of a transition from diesel powered vessels to low-carbon fuels. Significant efforts and investments are already being made within the industry for development, testing and roll-out of low-carbon fuels. The transition impacts the whole energy value chain, including the production of the low-carbon fuel, storage and distribution, and generation of power on-board the vessels, which are unique for each fuel type.

For shorter sea passages, hereunder short ferry connections which is the application that this project focuses on, fully battery-electric ferries are also an option. A number of full battery-electric ferries are already in operation, hereunder the Helsingør-Helsingborg ferry connection and the Søby-Fynshav ferry connection. However, for longer distances the power capacity and charging speed of fully electric ferries is a limiting factor.

Vessels powered by hydrogen fuel cells can provide somewhat longer sailing distances, with shorter fueling time. For larger vessels, ammonia is generally considered as a good and viable fuel. Ammonia is bunkered and stored in large, compressed tanks, and used in large two-stroke engines which are being developed for application of ammonia. The draw back to ammonia is that it is highly toxic and can only be carried with special care considering strict guidelines. The cost of green ammonia produced via green hydrogen must be expected to be more expensive than green hydrogen as it adds an additional production step.

Other low-carbon fuels like methanol and biofuels are also being considered. However, compared to hydrogen these fuels are considered less scalable in terms of volume.

The competition to hybrid battery - fuel cell propulsion systems is from combustion engines and from battery-electric propulsion systems. While diesel combustion engines have evolved over the last 100 years, the battery electric propulsion systems for maritime applications are in that light rather new and have mainly been commercially deployed in diesel electric hybrid systems over the last 20 years. Diesel electric hybrid propulsion system has proven to be a very reliable and cost-effective way of lowering the CO<sub>2</sub> emissions for maritime applications. The introduction of hydrogen and fuel cells will be able to take advantage of the yearlong development and improvement in diesel-electric propulsion for ships in an early effort towards electrification and towards a significant reduction of emissions. With the fuel cell in principle replacing the diesel generator in a hybrid solution, a fully zero emission solution is now within reach. The development will also be able to take advantage of the extensive experience with hydrogen and fuel cells for heavy duty land transport application such as fuel cell buses to support a cost competitive (TCO) business case for the fleet owners.

Looking at the competition from other FC providers, the use of hydrogen-powered fuel cells for ship propulsion is still at an early design or trial phase – with applications in smaller passenger ships, ferries or recreational crafts. The low- and high-temperature fuel cell (PEMFC) and the solid oxide fuel cell (SOFC) are seen as the most promising fuel cell types for maritime applications (EMSA 2017).

Fuel cell companies as Hydrogenics, PowerCell and Nedstack have, in the last couple of years, started projects in the maritime sector.

In June 2018, Hydrogenics has announced that they will provide Fuel Cells for First High-Speed Maritime Vessel in the U.S: <https://www.hydrogenics.com/2018/06/25/hydrogenics-to-provide-fuel-cells-for-first-high-speed-marine-vessel-in-the-u-s/>. The Swedish company PowerCell is offering fuel cell systems for marine applications: <https://www.powercell.se/en/markets/marine/>. And a fuel cell boat, touring the canals in Amsterdam is powered by fuel cell systems provided by Nedstack. <http://nedstack.nl/marine/>. Siemens offers fuel cells for military submarines these have been used in the German designed type 212A-class used by the German and Italian navy: <https://new.siemens.com/global/en/markets/marine/submarines.html>

Methanol powered fuel cells are also being marketed from both Serenergy and Blue World Technologies. This may be relevant in the future when the technology has had it's first trials in commercial operation over a period of time in less critical applications.

## 7. Project conclusion and perspective

This project proved that hydrogen fuel cells are a viable option as the focus turns to green and clean energy sources and reducing carbon emissions. The project work produced results that will pave the way to implementing a viable solution to meet the goals of decarbonising the marine industry while bringing Danish shipping to the forefront of the push to find cleaner solutions while maintaining a strong maritime presence.

The next steps for this technology will involve the completion of the certification process, the maturing of the concept modules into a commercially available product and the maturation of the hydrogen supply routes and storage options.

These project results prove that with the ingenuity of the Danish clean energy industry, the race to decarbonize the marine shipping environment is an attainable goal.

## 8. Appendices

- - International conference of Systems Engineering, Dec 2020. USA
- - International Symposium on Distributed Simulation and Real Time Applications, Aug 2020 Italy.
- - International Conference on Power and Energy Systems Engineering, Sept 2019 Japan.
- - IEEE Transaction on Power Electronics.
- - IEEE Transaction on Transportation Electrification.
- - IEEE Systems Journal.