



TASK 38 Final Report

Power-to-Hydrogen and

Hydrogen-to-X:

System Analysis of the techno-economic, legal, and regulatory conditions

Report coordinated by

Olfa Tlili, Christine Mansilla and Paul Lucchese

CEA-Université-Paris-Saclay

September 2020

Task members



Acknowledgments

This work is done in the framework of the Task 38 of the Hydrogen Technology Collaboration Programme, tackling Power to Hydrogen and Hydrogen to X systems and suggesting a system analysis of techno-economic, legal, and regulatory conditions related to Power to X deployment.

The Task 38 leadership team was composed of Paul Lucchese, working at CEA and chair of IEA Hydrogen TCP, creator and mentor of the task, Christine Mansilla and Olfa Tlili, from ITESE laboratory (laboratory on economic studies for energy systems) of French CEA, operating agent of the task.

The subtasks and task force leaders contribute a lot to the success of task 38: Joris Prost, Martin Robinius, JRC, Sheila Samsatli, Jonathan Leaver, Rob Dickinson, Laurence Grand Clement

This Task gathers more than 60 members coming from 39 organisations from 17 countries around the world.

We would like to thanks to all contributors to this final report and also Samantha Hilliard from Clean Horizon Lmt.

We would like to also thank IEA Hydrogen TCP executive Committee for their task approval and support as well as Hydrogen TCP secretariat, former one MRS Company, and the current secretariat Ariema.

We would like also to thank Capenergies, energy cluster in South of France and the secondee hired during 6 monthes, Zaher Chehade, who contribute a lot to establish the demo project database.

Last but not least, the CEA task management team was supported and partially funded by french energy agency Ademe. Special thanks for Ademe and Luc Bodineau for their help.

Foreword

When I proposed in 2015 to Hydrogen TCP Executive Committee to create a new task on “Power To gas”, this expression, “Power to gas” was pretty new and covered different meanings and acceptations. The word “Power to gas” appeared in early 2010’s to make concrete a new idea aligned with the dramatic growth of variable renewables sources in some countries: “why shouldn’t we use the excess of electricity we can observe in some period of time now (leading to some abnormal economic trends like negative electricity price!) to produce hydrogen, taken into account electricity is quite for free?”

Of course, the idea, free electricity to produce low carbon, low-cost hydrogen, was not quite right but many new type of projects appeared compared to previous period (before 2010) when mainly mobility projects and stationary applications were in the forefront of hydrogen landscape.

The rationale behind the creation of the task was to clarify and understand what was under Power to Gas concept: Power to Hydrogen and Hydrogen to X, to analyse the multiple demonstration projects from technical, economical and regulatory point of view.

Understanding better leads to recommendations, both for policy makers and business developers.

And so, the task was created, numbered Task 38, structured and received a very positive feedback from the very beginning.

This task was a success story from different points of view:

- Incredible human adventure: more than 50 people from 4 continents, 15 countries participated to task work
- Commitment and enthusiasm of experts more along the 4 years projects with high rate of participation in meetings
- Team building spirit around the management team composed of 10 people
- Geographical coverage: we organized plenary meetings and dedicated workshop around

the world in USA, in UK (Bath), in Japan, in New Zealand (Rotorua), in France (Aix en Provence (France) in Spain (Puertollano)

- Lot of deliverables: more than papers etc...a dedicated plenary session in Whcc 2016 in Brazil (Rio de Janeiro) and another one in IAEE 2021 in Paris.
- We are also very proud that one of our deliverables, the demo projects database, was extensively used in The IEA report “The future of Hydrogen”, delivered to G20 summit in Japan in 2019.

As I followed very closely the task and I was involved in its management, so I was called “father of the task” by my colleagues, or mentor of the task, much more official term. And I would like to thank especially Christine Mansilla, from CEA ITESE, the operating agent for the first 3 years who managed the task, the meetings with an extraordinary efficiency and human qualities, kind and helpful to everyone. She could be called “the mother of the Task”.

But the story is not over: Task 38 will have children: Task 41 focussed on data and modelling will continue to investigate some aspects of task 38, data base will be extended to deployment projects and used jointly as a reference data base by IEA secretariat and TCP, import/export scheme will be developed in a new task etc...

This report was done collectively and is reflecting well what we achieved during the last 4 years

Paul Lucchese

Hydrogen TCP Chair

Executive Summary

During four years of work, the Task38 experts have addressed and analysed different topics related to Power to X systems from techno-economic aspects to regulatory issues tackling the different hydrogen pathways. This report presents the results obtained from this collaborative exercise.

P2X pathway definitions have the aim to clarify terminologies that are often used but with different meanings or intentions which leads to misunderstanding and ambiguity. The Task Force Definitions have addressed this issue in the first chapter of this document, clarifying the terminologies adopted for the rest of the document. Once the hydrogen pathways from the production step to the application side are defined, the current hydrogen status is inspected. As numerous its energy applications are, hydrogen is mainly used today as a chemical component in industries like ammonia production and refineries. The energy related hydrogen pathways are currently mainly seen through demonstration projects. The Power to X demos around the world is reviewed and analysed within the framework of ST2. The results show that the investigated pathways are diversified with a recent trend towards hydrogen industrial applications attracting interest.

These demonstration projects aim at unlocking not only techno-economic but also regulatory and political bottlenecks.

In Chapter 3, a review of the incentives and regulatory barriers with regards to hydrogen deployment is proposed for twelve regions represented by Task38 experts (ST3B). This work has shown that the most acknowledged pathway, from a legal standpoint, is mobility applications. Only few countries are implementing legal frameworks for diverse H₂ applications, although in the recent years many countries have announced hydrogen specific roadmaps with high targets.

Besides the regulatory aspects, this report addresses the techno-economic side of P2X pathways analysis, starting with a review of studies tackling this issue (ST3A), and then focusing on electrolyser cost projections (Task Force EL data) assessing their impact on renewable hydrogen price settings. The objective is to offer policy makers and industry the comprehensive trends and guidelines for further electrolyser cost reduction into the MW-scale, while providing objective technological & economic arguments for converging towards a realistic electrolytic (and renewable) H₂ market price.

Addressing the electrolytic hydrogen could not be done without shedding light on the flexibility potential of its production process. Indeed, electrolysers can provide the electricity system with

security services and the third part of Chapter 4 details the services in question (Task Force Services to the Grid).

Regardless of the part of the supply chain to be tackled, three major kinds of stakeholders can influence the hydrogen deployment in a specific region:

- 1) industries setting the hydrogen system price (that depends on its costs),
- 2) policy makers that show ambition or not in hydrogen deployment and that act accordingly to make sure the regulatory framework is suitable for it,
- 3) and last but not least, analysts, academics and organizations running models and publishing energy system scenarios, so often used to enlighten industries and policy makers.

Hence, chapter 5 presents a review on the role of hydrogen in the renowned global energy scenarios analyzing whether hydrogen is suitably presented or not, based on the available techno-economic data, but also conducting a deeper analysis to inspect whether hydrogen pathways are well presented in the models used to generate the scenarios. Some conclusions and best practices for scenarios development and hydrogen modelling are provided (ST4). For accurate modelling, accurate data is needed, a discussion on data is hence proposed based on the learning from Task Force Data.

The report then presents the results of the specific case studies that were chosen by Task38 experts participating to the ST5. This part addresses the profitability conditions of specific applications in different countries with different geographical and political contexts.

Finally, yet importantly, the final part of the report proposes a set of techno-economic and policy related recommendations regarding Power to X development based on the expertise of Task38 members.

Table of contents

INTRODUCTION.....	14
General context.....	14
Part I: General framework for the development of the global hydrogen pathway.....	15
Part II: Literature and initiative review.....	20
Task 38 presentation.....	22
• Task Objectives and Description.....	22
• Framework.....	22
• Participants.....	24
Work done and outline of the report.....	24
REFERENCES.....	26
CHAPTER I.....	29
Task force: Power-to-Hydrogen and Hydrogen-to-X pathways: Clearing the Definitions from ambiguities.....	29
Abstract.....	30
Key words.....	30
Introduction.....	31
The limits of the power-to-gas concept.....	32
Screening the “power-to-hydrogen and hydrogen-to-x” pathways.....	33
A. The common step: Power-to-Hydrogen.....	33
B. Screening the Hydrogen-to-X pathways.....	33
C. Expanding the value chain via the provision of ancillary services.....	36
Conclusions: PTH-HTX opportunities for the energy system and beyond.....	37
Acknowledgements.....	37
REFERENCES.....	38
CHAPTER II.....	40
Subtask 2: Mapping and review of existing demonstration projects.....	40
Abstract.....	41
Keywords.....	41
Introduction.....	42

Methodology	44
Results	45
General outlook.....	45
Pathway trends (“Hydrogen-to-X”).....	46
Focus on Power-to-Hydrogen	50
Demonstration objectives	57
Conclusion	58
Acknowledgements	58
Appendix 1. list of the reviewed demonstration projects and location.....	59
REFERENCES.....	70
CHAPTER III	81
Subtask 3B: Review of the existing legal context and policy measures	81
Abstract	82
Keywords	82
Introduction.....	83
Incentives.....	84
Promoting low-carbon hydrogen production (PtH)	84
Incentives towards the use of hydrogen in the transport sector	85
Incentives towards the use of low-carbon hydrogen in the industry and for electricity production	87
Incentives towards blending with natural gas	87
Legal barriers	88
Regarding hydrogen production	88
Regarding hydrogen blending with natural gas	89
Regarding hydrogen use for the transport sector.....	90
General outlook.....	91
Conclusion and policy recommendations	92
Acknowledgements	94
REFERENCES.....	95
CHAPTER IV	100
Part 1: Subtask 3A: Review and analysis of the existing techno-economic studies on PtH and HtX ...	100
Abstract	101

Keywords	102
Introduction	103
Methodology for a structured international and collaborative review	105
Detailed analysis of review Step 2	108
Electricity Supply	108
Electrolysis	109
Power-to-X pathways	112
Discussion	115
Conclusion	116
Acknowledgements	117
Appendix	118
REFERENCES	132
Part 2: Task Force Electrolyser Data	145
Abstract	145
Keywords	145
Introduction	146
Results & discussion	148
Comparing CAPEX for electrolytic and SMR H ₂ production systems:	148
Comparing CAPEX for PEM and alkaline electrolyzers	150
Impact of CAPEX on electrolytic H ₂ price settings	153
Conclusions	157
Acknowledgements	157
REFERENCES	159
Part 3: Task Force Electrolyser Data	161
Abstract	161
Keywords	161
Introduction	162
Hydrogen production	163
Hydrogen production today	163
Green hydrogen production scale-up	166
Fossil parity for green hydrogen	168

The cost of electrolytic hydrogen.....	168
The scale of fossil parity for green hydrogen.....	174
Conclusion	176
Acknowledgements	176
REFERENCES.....	178
Part 4: Task Force Security Services	180
Introduction.....	181
Electrical energy commodity trading (EECT).....	181
Electricity system security markets (ESSM / Markets for ancillary services).....	187
Summary of potential roles for power to hydrogen	191
A more detailed review of key global market and non-market security mechanisms.....	196
1. Definitions and technical requirements of ancillary services (focus on frequency regulation) in several electricity markets.....	196
2. Definition of energy balancing services (focus on demand management)	208
Verordnung zu abschaltbaren Lasten – "AbLaV" (Switchable loads and fast disconnectable loads)	210
Electrolyser and fuel cell technical specifications	210
Economics and efficiency of power to gas systems	212
Previous studies pertaining to hydrogen participation in electricity markets and services to the grid	213
Demonstrations which have investigated aspects regarding services to the grid	215
Conclusions and remarks.....	219
REFERENCES.....	220
CHAPTER V	224
Part 1: Subtask 4 - Systemic approach - The curious case of the conflicting roles of hydrogen in global energy scenarios.....	224
Abstract	225
Introduction.....	226
Global energy scenarios and the representation of hydrogen.....	227
Energy scenarios.....	227
Hydrogen representation in global energy scenarios	230
Conflicting roles of hydrogen in global scenario results	232

Discussion: what must scenarios do to represent hydrogen fairly?	234
Scenarios must use appropriate modelling tools	234
Models must capture sufficient temporal detail	235
Models must capture sufficient spatial detail.....	235
Models must appropriately represent technologies and inter-sectoral connectivity	236
Models must represent the complexity of consumer behaviour	236
Models must remain manageable and user-friendly	237
Model methodologies must be transparent	237
Challenges and pitfalls.....	238
Scenarios must be designed appropriately	239
Scenarios must include all relevant sectors	239
Scenarios must be technology rich: a technology not included will not appear in the results	240
Scenarios must have an appropriate level of ambition	241
Scenarios must consider other objectives	242
Scenarios must use consistent and substantiated data assumptions.....	242
Conclusions.....	244
Authors' contribution	245
Conflicts of interest	245
Acknowledgements	245
REFERENCES.....	247
Part 2: Task Force – Data – The challenge of a collaborative database to support evolving modeling needs	254
Database – General considerations.....	254
Database in the IEA Hydrogen TCP Tasks	255
The need for an ad hoc effort around data management	256
CHAPTER VI	258
Subtask 5: Power to X Case studies	258
Introduction.....	259
Methodology	260
Specific Business Case 1. Power to Green Ammonia for Blasting Industry in Chile	262
Specific Business Case 2. Power to Green Ammonia Produced in Australia and Transport to Japan (to	

use as hydrogen).....	267
Specific Business Case 3. Power to Green Hydrogen in Austria	279
Specific Business Case 4. Power to Green Hydrogen from Patagonia to Japan	284
Specific Business Case 5. Power to Hydrogen with Waste CO2 from Green Methanol in China	293
Conclusions.....	299
REFERENCES.....	301
GENERAL CONCLUSIONS AND RECOMMENDATIONS.....	303
Techno-economic recommendations.....	303
Political recommendations.....	308
Pathway specific policy recommendations	309
Modelling related recommendations.....	313
1) Scenarios must use appropriate modelling tools.....	313
2) Scenarios must use consistent and substantiated data assumptions	314
REFERENCES.....	315
MAJOR TASK ACCOMPLISHMENTS	317
• Round table organization and participation at WHEC 2018: “The Role of Hydrogen in the Energy Policies”	317
• Workshop on demonstrations (ST2) in Aix-en-Provence	318
• Workshop on hydrogen in energy models in Bath (ST4)	319
• Workshop on Hydrogen in the Mediterranean region (ST5) in Puertollano	320
• Communication:	321
Papers.....	321
Participation to conferences (WHEC, P2G, EEM, IAEE)	322
Technology briefs	323
• Award for the Operating Agent: Christine Mansilla	323
FORWARD LOOKING	325
APPENDICES	328

INTRODUCTION

General context

Making the energy system more sustainable, with a significant reduction of CO₂ emissions in accordance with the Paris COP21 agreement [1], is the guiding principle of national energy policies. 175 of 197 Parties have ratified the COP21 agreement, with the following goals: to limit global warming within 2°C above pre-industrial levels and aim to limit it to 1.5 °C; set global emissions to collectively peak as soon as possible; and to reduce emissions in accordance with the best available science.

Within this general framework, three major challenges can be highlighted:

1. The main challenge is the limitation of the collective costs of the global warming effects, whose hulking forecasted scale has been outlined by the work of the IPCC. Due to the global and external nature of pollution in the production system, it is mainly from political action that depends decarbonisation of energy on. Given the need to involve huge investments needed to build new infrastructure, political action has a major role in meeting coordination needs and developing a strong and clear vision, allowing market players to position themselves in the market over the long term.
2. The emergence of technological solutions free of greenhouse gas emissions, which are presented as serious alternatives to carbon energies, in terms of costs and potential quantities, is the collateral challenge. These solutions give rise to a new market presenting an exceptional economic development opportunity for companies. The global potential turnover will be around trillions of dollars per year by 2030¹, shared between investments in infrastructures and equipment and final operations. Because of the high level of investments required, from upstream research to new infrastructure to be built downstream, it depends ultimately on the private sphere, and more specifically on the choices and flexibility of entrepreneurs, investors and consumers. In a transition phase, investments in infrastructures from local or national authorities [3] can be a major catalyst for starting a dynamic on new energies. Given the learning costs, policy facilitations will also play a major role in the dynamics of transition in terms of standardization and incentives.
3. There is a third and equally crucial challenge, which could be described as the "overall acceptability" of the transition, and in particular, of the technical, economic and organizational solutions adopted. This growing acceptability includes the adherence, or even the demands, of

¹ According to the 2017 OECD report *Investing in Climate, Investing in Growth* [2], total investment needs for infrastructure are estimated to be around USD 6.3 trillion annually between 2016 and 2030

citizens, but also of industries and States, including most of the countries currently exporting fossil fuels, which have an opportunity for effective prospects for the conversion of their economies, in accordance with their requirement to maintain energy income over time.

Part I: General framework for the development of the global hydrogen pathway

The zero-carbon horizon and its challenges

In line with the climate actions, targeting a zero carbon energy system (such as in Europe for the timeframe of 2050 [4]²³) is characterized first of all by the achievement of a substantial overall gain in energy efficiency and energy sobriety. This gain must offset the energy needs linked to growth, particularly in developing countries, in order to stabilize or even reduce global primary energy consumption.

The Zero Carbon Horizon (ZCH) is also and above all characterized by the substitution of primary sources of fossil origin (oil, gas and coal) by non-carbon sources. This substitution is conditioned by the capacity of the world economic system to mobilize the investments necessary for the development of new production infrastructures. Among these alternative sources, focus is on developing solar photovoltaic and wind power, and, probably to a lesser extent, nuclear, bioenergy, hydroelectric and tidal power.

As part of the energy transition and ZCH, it is expected that electricity will gain importance as an energy vector [5]. The overall production structure of renewable electricity (RES-E) will also be different from today's system structure. Two new forms of production with relatively opposite profiles will in fact complement national productions, presenting opportunities for energy provision but also some challenges to overcome:

1. The first form of complementary production goes towards decentralization, on the scale of individual dwellings or, of local communities (village, isolated zone, urban district), whether in developed countries, for example like what was massively set up Germany [6], or in emerging countries. The motivations can be economic, social and environmental. In many scenarios, it is more rational to invest in decentralized local production than in new distribution and transport infrastructure. A typical illustration is found in photovoltaic household-production systems, but

² <https://eur-lex.europa.eu/legal-content/EN/TXT/?qid=1588581905912&uri=CELEX:52020PC0080>

³ The European Green Deal : https://www.europarl.europa.eu/doceo/document/TA-9-2020-0005_EN.pdf : « The European Parliament [] calls for the necessary transition to a climate-neutral society by 2050 at the latest and for this to be made into a European success story”

also in energetically efficient combined heat and power (CHP) systems [7]. In addition, in this decentralized context, a certain number of complementary technical production solutions, rather marginal on a global scale, such as the energy treatment of biomass or waste for example (for electricity-heat cogeneration, hydrogen production, etc.), are of particular local and environmental importance.

The potential benefits of renewable energies for local ecosystems (public service mission, development of know-how, activities and jobs, public revenue returns, energy independence), legitimizes the mobilization of facilitation resources by public authorities. Their assistance is especially awaited on the development of the required infrastructures in organizational or financial (e.g. premium) forms. Although propitious to the development of regions and their independency, the decentralized structure may have some limits. Indeed, renewable resources do not have the same abundance everywhere, and some regions might be in excess of energy potential while others lack resources. Hence, there is still a need for transporting the energy from one region to the other to balance the system, and this will highly depend on the capacity of the electric system, for example, to cope with such new electricity flows.

2. The second form of energy production structure, on the contrary, looks like massive oligo-centric production, intended for international trade, a little like the structure of the current oil market. The motivations, economic, social and environmental, of this oligo-centric form are twofold:
 - The national supply issues lead the first motivation of this global production structure, mainly linked to temporal and geographic global asymmetries between supply and demand. These asymmetries are manifested for certain nations by the expected deficit of domestic energy capacities with, for example, the closure of traditional power stations (fossil or nuclear thermal) or the local scarcity of renewable resources. It leads to the need for imports, for example in the form of hydrogen as Japan has planned [8] for its own demand.
 - The need for economic efficiency leads the second motivation. It comes from the fact that there exists on the earth specific privileged sites for mass renewable energy production, meeting a double constraint: the cost minimization of energy production related to an attractive capacity factor (making systems already competitive in 2020), and the land availability that does not compete with vital areas like agricultural zones, forestry and inhabited areas. Among these sites, we can mention in a non-exhaustive manner, the Arabian Peninsula, the southernmost part of South America, the west of the US, Australia or North Africa. Although very attractive, these production centers can be far from the demand hubs, hence requiring energy transmission and distribution options. The latter must be economically feasible and environmentally friendly otherwise the low carbon and economic logic will be hard to keep.

Finally, beyond this triangular production structure (national centralized, national decentralized, internationally imported), another specificity of variable renewable production is its fatal and intermittent nature, which requires the development of techniques for smoothing/buffering the

production/consumption differential and preserving the balance of the energy system.

For instance, different complementary competitive solutions can ensure the balance of the electricity system:

1. Large-scale real-time transport and distribution lines,
2. Storage options,
3. Power plants flexibility
4. Adaptation between final consumption and production, probably more marginally in terms of quantity, using so-called smart grid techniques and fine management of the supply/demand balance.

Accordingly, the mass development of renewable energies requires both temporal and geographic flexibility in order to be put in place in the most optimal way (technically, economically, environmentally and socially).

Nonetheless, in order to reach a zero-carbon energy system, thinking beyond the electric system is required. Other sectors like transport which accounts for nearly 22.7% of the total energy related CO₂ emissions [9] will need to be considered in the decarbonisation strategy. Transportation is challenging, being so far highly dependent on fossil fuel combustion engines. However, governmental pledges have been set in several regions worldwide. The European Union (EU) has set CO₂ reduction targets for the transport activity aiming to reach a 95 gCO₂/km cap by 2020. These targets are ambitious compared to the ones announced by the United States (US), China and Japan (121, 117 and 105 gCO₂/km respectively) [10]. Accordingly, new transport technologies have emerged aiming for a “cleaner” mobility provision.

The same logic is applicable to the industrial and residential sectors. However, tackling each sector apart might not be the most efficient way, compared to adopting a multi-sectorial decarbonisation approach. Synergies between sectors can be created.

Understanding these challenges and projections concerning the development of the energy system, hydrogen can present a promising option allowing to contribute to fulfilling the ZCH target.

Opportunities for hydrogen in energy systems

Apart from small reserves of “natural” hydrogen [11], hydrogen is not a resource that can be extracted at scale in the same way as fossil fuels. Today, hydrogen is mainly produced via steam methane reforming (SMR) which is highly carbonized. However, it can be produced with minimal GHG emissions, for example through electrolysis powered by renewable electricity [12], or from bioenergy or fossil fuels with carbon capture and storage (CCS) [13]. Hydrogen has many possible energy applications, including for heating, transport, industry, and electricity generation [14], [15].

There are many possible pathways for hydrogen in energy systems and in some cases; they are already being realized in real projects. In this section, the main pathways are summarized; an overview is provided in Fig. 1, whilst next chapter describes them in more detail.

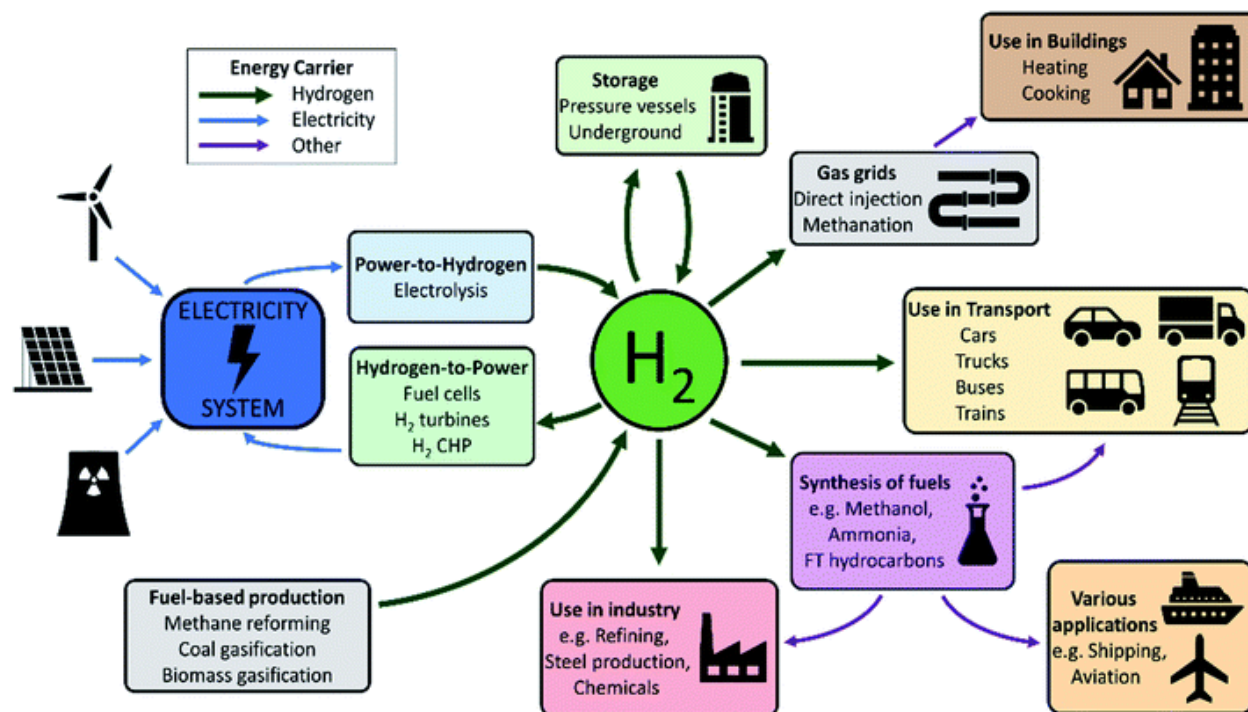

Fig. 1 Overview of key hydrogen production and usage pathways. With multiple production options and applications, hydrogen could be valuable in providing flexibility and sector-coupling to energy systems.

Today, hydrogen is already a key chemical component in many industrial markets: the main applications include ammonia synthesis (55% of hydrogen demand); hydrocracking and hydrodesulphurization in refineries (25%); and methanol production (10%) [16].

However, hydrogen systems can also be key enablers to promote promising synergies between sectors, thanks to the hydrogen versatility [17]. The produced hydrogen can be used for both chemical purposes and energy applications: industry, transport, heating, power generation, etc. [17], [18].

Accordingly, provided that hydrogen (H_2) is produced via low carbon technologies such as electrolysis coupled with a decarbonized power mix, multi-sectorial decarbonisation can be achieved.

Once produced, hydrogen can be stored in quantities from MWh to TWh, for example in pressurized cylinders or underground in salt caverns, depleted oil and gas reservoirs and saline aquifers [19],

[20]. Pressurized hydrogen storage has a volumetric energy density greater than 500 kWh m^{-3} , far exceeding low-carbon energy storage alternatives (up to 1.5 kWh m^{-3} for pumped hydro storage (PHS) and 12 kWh m^{-3} for compressed air energy storage (CAES)) [21].

Hydrogen's high energy density makes it particularly interesting for system-wide energy balancing. Hydrogen could be manufactured from electricity at times of excess supply, stored, and later converted back to electricity or used for other purposes at times of high demand [12]. However, hydrogen storage round-trip efficiencies are around 30-56%, depending on the electrochemical technology used, which is low compared to alternatives (PHS: 70–85%; CAES: 65–80%; battery: 86–95%) [22]. Therefore, the value of hydrogen energy storage depends on the trade-off between the benefits of time-shifting bulk energy, and the costs of the efficiency losses.

Whilst hydrogen for electricity storage has not yet been deployed at large scale, already several projects have deployed electrolyzers to absorb electricity from wind farms, to be stored and used at a later date in various applications (for example Energiepark Mainz [23] and Lam Takhong [24]). For the 2020 Olympics, postponed to 2021, Tokyo planned to power the Olympic village with hydrogen from solar-powered electrolysis [25].

As an attractive means of storage, but also transport and distribution of energy, hydrogen can present a fundamental complement to RES-E production, in a new global energy paradigm. The hydrogen trade, which could be one of the most promising solutions for energy exchanges, would follow the logic of international trade [26], [27]. The issue is linked to the choice of technologies and standards for conditioning, storage, and transport (CSTs), which will minimize both GHG emissions and the costs of long-distance exchanges. The economic maturity of CSTs is to be investigated more closely in the development of the international hydrogen trade.

1. For the international long-distance market, green hydrogen production from RES-E, according to the most current estimates by 2030, would be considered, in gaseous (CHG), liquid or synthetic form (NH_3 , CH_4 , LOHC...), as a competitive technical transport and distribution solution to complement the direct electricity distribution infrastructure. Direct electric transport in particular can be very costly and less effective over very long distances (apart from social acceptance issues towards electricity lines installation nearby households).

2. For decentralized production solutions, PtH and HtP will complement the RES-E electrical system as a means of balancing production and consumption, while avoiding new investments in the electrical network. The distribution networks actually, where they exist, will have to absorb additional decentralized productions which is not evident in some cases.

Hence hydrogen allows to provide the energy system with both temporal and geographic flexibility in the context of the rising shares of renewables.

Hydrogen's suitability for storage also makes it appealing as a transport fuel. A hydrogen fuel tank and fuel cell can provide the electricity supply for an electric vehicle, or hydrogen can be burned in an internal

combustion engine. Hydrogen is seen as a possible low-carbon fuel in transport sectors that require long ranges, such as road freight, rail and shipping [15], [28]. Hydrogen in passenger vehicles could also offer greater driving ranges, faster refueling times and in some cases lower cost of ownership compared to battery electric vehicles [18], [29].

The transport sector has seen the greatest interest in hydrogen so far and there is considerable interest globally in expanding the use of hydrogen as a transport fuel. There are over 350 hydrogen fueling stations worldwide, across the Americas, Europe, Asia and Oceania [30]. Hydrogen buses are in use in many cities around the world including in USA, Japan, China and several countries in Europe [31], [32]. Alstom have developed a hydrogen train, the first of which went into operation in Lower Saxony, Germany in 2018 [33].

Hydrogen can also be combined with captured CO₂ in carbon capture and utilization (CCU) processes. CCU can produce useful energy carriers that are already in use and have existing infrastructures, such as methane, methanol and liquid hydrocarbons [34], [35]. The CO₂ used in CCU could be captured from fossil sources, but increased environmental benefit would be achieved if the CO₂ were captured from biomass or directly from the air [36]. Hydrogen can also be combined with nitrogen to produce ammonia, which has advantages for storage and transport, and can be used for heat and power generation [37].

Hydrogen can also be injected in the natural gas systems contributing to greening the latter. This injection can be either direct up to specific percentages depending on the final use, or after methanation to produce CH₄ that can be injected with no limitations. This helps decarbonize all the downstream uses of natural gas in buildings and industry (heating, cooking, etc.).

To sum up, hydrogen has a promising potential allowing a simultaneous and multi-sectoral decarbonisation [27]. It also contributes in promoting the renewable energy penetration by providing the flexibility to the electric system as well as creating new roots for this energy towards final uses in different sector, also named “sector coupling”. A concept in which the energy system is more connected, where electricity systems, gas systems and all sectors can contribute in a coherent and efficient way to the energy system decarbonisation.

Part II: Literature and initiative review

Facing its promising potential, the interest in hydrogen have increased drastically lately. Many reports have been published by renowned organizations, analyzing the potential of hydrogen in the context of the energy transition.

For instance, the IEA report “The Future of Hydrogen” (2019) [27] prepared for the G20 meeting addresses the whole hydrogen supply chain from the production step to final uses detailing the different pathways and involved technologies with a focus on the potential future volumes and costs for each pathway. A set

of policy recommendations is then proposed.

Following this big report, the Hydrogen Council have recently published a study on hydrogen costs evolution [26], detailing the promising cost reduction potential in the years to come once the required volumes are reached. The report conveys the message that competitiveness is already reached for several applications and that industries are ready to upscale but there is still a need for a clearer political vision (clear strategies and adequate regulation ...) and support to trigger the markets.

The novelty about these reports compared to previous ones [38]–[41] on hydrogen is the uptake on the role of international trade, and the interesting potential of several regions in terms of renewable hydrogen generation at competitive costs.

Next to the multiplicity of publications, many initiatives have also been growing around hydrogen, on the international as well as the regional levels.

The following is a selection of international hydrogen collaboration platforms:

- Mission Innovation 8th Challenge on Hydrogen
- Clean Energy Ministerial, Hydrogen Initiative
- World Economic Forum, Hydrogen task force
- Hydrogen Council
- International Energy Agency (IEA) Hydrogen Technology Collaboration Programme (TCP)
- International Partnership for Hydrogen and Fuel Cells in the Economy (IPHE)
- International Association for Hydrogen Energy (IAHE)
- Hydrogen Europe (European Hydrogen and Fuel Cell Association)
- U.S. Department of Energy's (DOE's) Fuel Cell Technologies Office
- Fuel Cells and Hydrogen Joint Undertaking (FCH JU)

Among these initiatives, the IEA Hydrogen Technology Collaboration Programme (TCP) is an international global resource for expertise on hydrogen. For over 40 years, the hydrogen TCP of the IEA have provided a unique management of coordinated hydrogen research, development, and demonstration activities on a global basis.

With over 40 tasks (annexes) created so far, the Hydrogen TCP addressed a comprehensive wide range of research fields.

The Task 38 is one of these tasks, tackling Power to Hydrogen and Hydrogen to X systems and suggesting a system analysis of techno-economic, legal, and regulatory conditions related to Power to X deployment.

Task 38 presentation

The “Power-to-hydrogen” concept means that hydrogen is produced via electrolysis. Electricity supply can be either from the grid, off-grid, or mixed systems.

“Hydrogen-to-X” implies that the hydrogen supply concerns a large portfolio of uses:

- transport (hydrogen for fuel cells, biofuels, synthetic methane for transport etc.),
- natural gas grid (by blending hydrogen directly with natural gas or synthesizing methane and blending it into the natural gas grid),
- re-electrification through hydrogen turbines or fuel cells,
- general business of merchant hydrogen for energy or industry, especially refinery, steel industry, ammonia, etc.,
- ancillary services or grid services for the electricity grid, transport or distribution grid. Hydrogen provides a flexible energy storage and carrier option which could defer the need for new lines and would alleviate the transmission difficulties.

- [Task Objectives and Description](#)

The general objectives of the Task are to:

- Provide a comprehensive understanding of various technical and economic pathways for power-to-hydrogen applications in diverse settings
- Provide a comprehensive assessment of existing legal frameworks for hydrogen systems
- Present business developers and policy makers with general guidelines and recommendations which enhance hydrogen system deployment in energy markets.

The final objective is to develop hydrogen visibility as a key energy carrier for a sustainable and smart energy system, within a two or three horizon time frame: e.g. 2020, 2030 and 2050.

- [Framework](#)

The task is organized in subtasks (ST) and task forces (TF). Task forces aim at supplying the subtasks with data and methodology throughout the task duration. Subtask workshops are organized in order to advance the project as well as plenary meetings which are organized on a semi-annual basis.

The subtasks and task forces are presented below.

Subtask	Subtask Name	Subtask Leader	Subtask Activities
1	Management, strategy and communication	Paul Lucchese, Christine Mansilla and Olfa Tlili, CEA, France (support from Samantha Hilliard, Clean Horizon)	<ul style="list-style-type: none"> - Involving new experts - Coordination (meeting organization, private website update, ST/TF activity follow-up) - Interfacing (IEA, HyLaw, Hydrogen Council, Task 36, CEN/CENELEC)
2	Mapping and review of existing demonstrations	Joris Proost, Université Catholique de Louvain, Belgium	<ul style="list-style-type: none"> - Review of existing databases - Proposal of a roadmap
3A	Review and analysis of the existing techno-economic studies on PtH HtX	Martin Robinius, Forschungszentrum Jülich, Germany	<ul style="list-style-type: none"> - Literature review and analysis - Determine database requirements
3B	Review of the existing legal context and policy measures	Francesco Dolci, JRC, European Commission	<ul style="list-style-type: none"> - Review of existing legal frameworks and policy measures for hydrogen systems
4	Systemic approach	Sheila Samsatli, University of Bath, United Kingdom	<ul style="list-style-type: none"> - Analysis of energy system models - Outlook for hydrogen from a system perspective
5	Case studies	Gema Alcalde and Carlos Fúnez Guerra, Centro Nacional del Hidrógeno, Spain	<ul style="list-style-type: none"> - Identification and analysis of relevant case studies
Task Force	Task force Name	Task force Leader	Task force Activities
Definitions	Definitions	Rob Dickinson, Hydricity Systems, Australia	<ul style="list-style-type: none"> - Specifying the terming and definitions related to PtH and HtX systems
Data	Data	Laurence Grand-Clément, PersEE, France	<ul style="list-style-type: none"> - Developing tool for data management and sharing according to group requirements
Electrolyzer data	Electrolyzer data	Joris Proost, Université Catholique de Louvain, Belgium	<ul style="list-style-type: none"> - Analysis and communication of recent technical and economic electrolyzer data

Services to the grid	Services to the grid	Rob Dickinson, Hydricity Systems, Australia Pierluigi Mancarella, University of Melbourne, Australia	- Identify the possibilities for PtH, in different regional contexts
-----------------------------	----------------------	---	--

- **Participants**

Over 60 experts from 15 countries are involved in Task 38. The Task is coordinated by the French CEA/Itésé, supported by the French ADEME. Participating IEA Hydrogen TCP ExCo Members are: Australia, Austria, Belgium, European Commission, France, Germany, Hychico, Japan, The Netherlands, New Zealand, Norway, Southern Company, Spain, Sweden, United Kingdom and the United States.

Work done and outline of the report

In what follows, the results of the Task38 will be presented, not necessarily in the chronological order they were conducted or in the order of the subtasks.

The document hence starts with a work on P2X pathway definitions with the aim to clarify terminologies that are often used but with different meanings which leads to misunderstanding (Task Force Definitions). Once the hydrogen pathways from the production step to the application are defined, the second chapter tackles the current hydrogen status. As numerous its energy applications are, hydrogen is mainly used today as a chemical component in industries like ammonia production and refineries. The energy related hydrogen pathways are currently mainly seen through demonstration projects. Hence, the second chapter of this document suggests a review of the P2X demos around the world. Within the framework of ST2, a workshop was organized, in which the organizations behind the reviewed demos-project expressed the challenges of P2X pathways deployment. These challenges are mainly related to cost and regulatory issues.

In Chapter 3, a review of the incentives and regulatory barriers with regards to hydrogen deployment is proposed for several regions represented by Task38 experts (ST3B). Chapter 4 addresses the techno-economic aspect of P2X pathways, starting with a review of studies tackling this issue (ST3A), and then focusing on electrolyser cost projections (Task Force EL data) assessing their impact on renewable hydrogen price settings. A fourth part of Chapter 4 also addresses the flexibility potential of electrolysis and the possibility to provide services to the grid, services that can help improve the profitability of hydrogen production (Task Force Services to the Grid).

Three kinds of stakeholders can influence the hydrogen deployment in a specific region:

- 1) industries setting the hydrogen system price (that depends on its costs),
- 2) policy makers that show ambition or not in hydrogen deployment and that act accordingly to make sure the regulatory framework is suitable for it,
- 3) and last but not least, academics and organizations running models and publishing energy system scenarios, so often used to enlighten industries and policy makers.

Chapter 5 presents a review on the role of hydrogen in the renowned global energy scenarios analyzing whether hydrogen is suitably presented or not, based on the available techno-economic data, but also conducting a deeper analysis to inspect whether hydrogen pathways are well presented in the models used to generate the scenarios. Some conclusions and best practices for scenarios development and hydrogen modelling are provided (**ST4**). For accurate modelling, accurate data is needed, a discussion on data is hence proposed based on the learning from **Task Force Data**.

In Chapter 6, the **ST5** case studies are conducted and analyzed.

Finally, yet importantly, the final chapter of the results part proposes a set of recommendations regarding P2X development based on the expertise of Task38 members.

REFERENCES

- [1] U. Nations, « Paris agreement », *U. N.*, 2015.
- [2] OECD, « Investing in Climate, Investing in Growth ». 2017, Consulté le: juill. 30, 2020. [En ligne]. Disponible sur: https://read.oecd-ilibrary.org/economics/investing-in-climate-investing-in-growth_9789264273528-en.
- [3] D. Röttgers, A. Tandon, et C. Kaminker, « OECD Progress Update on Approaches to Mobilising Institutional Investment for Sustainable Infrastructure », n° 138, 2018, doi: <https://doi.org/https://doi.org/10.1787/45426991-en>.
- [4] European Commission, « 2050 long-term strategy », *European Commission, Climate Strategies & Targets*. https://ec.europa.eu/clima/policies/strategies/2050_en (consulté le mai 29, 2019).
- [5] International Energy Agency (IEA), « World Energy Outlook ». 2019.
- [6] C. Burger et J. Weinmann, « Chapter 3 - Germany's Decentralized Energy Revolution », in *Distributed Generation and its Implications for the Utility Industry*, F. P. Sioshansi, Éd. Boston: Academic Press, 2014, p. 49-73.
- [7] P. E. Dodds *et al.*, « Hydrogen and fuel cell technologies for heating: A review », *Int. J. Hydrog. Energy*, vol. 40, n° 5, p. 2065-2083, févr. 2015, doi: 10.1016/j.ijhydene.2014.11.059.
- [8] M. Nagashima et Institut français des relations internationales, *Japan's hydrogen strategy and its economic and geopolitical implications*. 2018.
- [9] International Energy Agency - IEA, *World Energy Outlook*. 2016.
- [10] McKinsey, « Electric vehicles in Europe: gearing up for a new phase? » 2014.
- [11] A. Prinzhofer *et al.*, « Natural hydrogen continuous emission from sedimentary basins: The example of a Brazilian H₂-emitting structure », *Int. J. Hydrog. Energy*, vol. 44, n° 12, p. 5676-5685, 2019, doi: <https://doi.org/10.1016/j.ijhydene.2019.01.119>.
- [12] S. Schiebahn, T. Grube, M. Robinius, V. Tietze, B. Kumar, et D. Stolten, « Power to gas: Technological overview, systems analysis and economic assessment for a case study in Germany », *Int. J. Hydrog. Energy*, vol. 40, n° 12, p. 4285-4294, avr. 2015, doi: 10.1016/j.ijhydene.2015.01.123.
- [13] IEA, « IEA Greenhouse Gas R&D Programme, Techno-Economic Evaluation of SMR Base Standalone (Merchant) Hydrogen Plant with CCS ». 2017, [En ligne]. Disponible sur: <https://ieaghg.org/component/content/article/49-publications/technical-reports/784-2017-02-smr-based-h2-plant-with-ccs>.
- [14] M. Ball et M. Weeda, « The hydrogen economy – Vision or reality? » This paper is also published as Chapter 11 'The hydrogen economy – vision or reality?' in *Compendium of Hydrogen Energy Volume 4: Hydrogen Use, Safety and the Hydrogen Economy*, Edited by Michael Ball, Angelo Basile and T. Nejat Veziroglu, published by Elsevier in 2015, ISBN: 978-1-78242-364-5. For further details see: <http://www.elsevier.com/books/compendium-of-hydrogen-energy/ball/978-1-78242-364-5>. », *Int. J. Hydrog. Energy*, vol. 40, n° 25, p. 7903-7919, juill. 2015, doi: 10.1016/j.ijhydene.2015.04.032.
- [15] N. P. Brandon et Z. Kurban, « Clean energy and the hydrogen economy », *Phil Trans R Soc*, vol. 375, 2017, doi: <https://doi.org/10.1098/rsta.2016.0400>.
- [16] « Hydrogen Europe », *Hydrogen in Industry*, 2019. <https://hydrogeneurope.eu/hydrogen-industry> (consulté le juin 14, 2019).
- [17] SBC Energy Institute, « Leading the Energy Transition Factbook, Hydrogen-based energy conversion - More

than storage: system flexibility ». 2014.

[18] International Energy Agency, « Technology Roadmap Hydrogen and Fuel Cells ». 2015, [En ligne]. Disponible sur:

<https://www.iea.org/publications/freepublications/publication/TechnologyRoadmapHydrogenandFuelCells.pdf>.

[19] F. Zhang, P. Zhao, M. Niu, et J. Maddy, « The survey of key technologies in hydrogen energy storage », *Int. J. Hydrog. Energy*, vol. 41, n° 33, p. 14535-14552, sept. 2016, doi: 10.1016/j.ijhydene.2016.05.293.

[20] R. Tarkowski, « Underground hydrogen storage: Characteristics and prospects », *Renew. Sustain. Energy Rev.*, vol. 105, n° C, p. 86-94, 2019.

[21] A. B. Gallo, J. R. Simões-Moreira, H. K. M. Costa, M. M. Santos, et E. Moutinho dos Santos, « Energy storage in the energy transition context: A technology review », *Renew. Sustain. Energy Rev.*, vol. 65, p. 800-822, nov. 2016, doi: 10.1016/j.rser.2016.07.028.

[22] A. Abdon, X. Zhang, D. Parra, M. K. Patel, C. Bauer, et J. Worlitschek, « Techno-economic and environmental assessment of stationary electricity storage technologies for different time scales », *Energy*, vol. 139, p. 1173-1187, nov. 2017, doi: 10.1016/j.energy.2017.07.097.

[23] « Energiepark Mainz: Energiepark Mainz ». <https://www.energiepark-mainz.de/> (consulté le juill. 26, 2020).

[24] Electricity Generating Authority of Thailand, « EGAT to develop the first wind hydrogen hybrid in Asia to support the future of renewable energy ». <https://www.egat.co.th/en/news-announcement/news-release/egat-will-develop-the-first-wind-hydrogen-hybrid-in-asia-to-support-the-future-of-renewable-energy> (consulté le juill. 26, 2020).

[25] Ministerial Council on Renewable Energy, « Hydrogen and Related Issues, Basic Hydrogen Strategy », 2017, [En ligne]. Disponible sur: http://www.meti.go.jp/english/press/2017/pdf/1226_003b.pdf.

[26] Hydrogen Council, « Path to hydrogen competitiveness A cost perspective ». 2020, [En ligne]. Disponible sur: https://hydrogencouncil.com/wp-content/uploads/2020/01/Path-to-Hydrogen-Competitiveness_Full-Study-1.pdf.

[27] IEA, « The Future of Hydrogen », p. 203, juin 2019.

[28] G. Anandarajah, W. McDowall, et P. Ekins, « Decarbonising road transport with hydrogen and electricity: Long term global technology learning scenarios », *Int. J. Hydrog. Energy*, vol. 38, n° 8, p. 3419-3432, mars 2013, doi: 10.1016/j.ijhydene.2012.12.110.

[29] E. Ruffini et M. Wei, « Future costs of fuel cell electric vehicles in California using a learning rate approach », *Energy*, vol. 150, p. 329-341, mai 2018, doi: 10.1016/j.energy.2018.02.071.

[30] « Hydrogen Refuelling Stations Worldwide », *H2stations.org*. <http://www.netinform.de/h2/h2stations/default.aspx>.

[31] T. Hua *et al.*, « Status of hydrogen fuel cell electric buses worldwide », *J. Power Sources*, vol. 269, p. 975-993, déc. 2014, doi: 10.1016/j.jpowsour.2014.06.055.

[32] B. Verheul, « Overview of hydrogen and fuel cell developments in China », *Holl. Innov. Netw. China*, 2019, [En ligne]. Disponible sur: <http://www.nederlandwereldwijd.nl/binaries/nederlandwereldwijd/documenten/publicaties/2019/03/01/waterstof-in-china/Holland+Innovation+Network+in+China+-+Hydrogen+developments.+January+2019.pdf>.

[33] ALSTOM, « Alstom's hydrogen train Coradia iLint first successful run at 80 km/h », mars 14, 2017. <http://www.alstom.com/press-centre/2017/03/alstoms-hydrogen-train-coradia-ilint-first-successful-run-at-80-kmh/>.

- [34] S. M. Jarvis et S. Samsatli, « Technologies and infrastructures underpinning future CO2 value chains: A comprehensive review and comparative analysis », *Renew. Sustain. Energy Rev.*, vol. 85, p. 46-68, avr. 2018, doi: 10.1016/j.rser.2018.01.007.
- [35] C. J. Quarton et S. Samsatli, « The value of hydrogen and carbon capture, storage and utilisation in decarbonising energy: Insights from integrated value chain optimisation », *Appl. Energy*, vol. 257, p. 113936, janv. 2020, doi: 10.1016/j.apenergy.2019.113936.
- [36] H. A. Daggash, C. F. Heuberger, et N. Mac Dowell, « The role and value of negative emissions technologies in decarbonising the UK energy system », *Int. J. Greenh. Gas Control*, vol. 81, p. 181-198, févr. 2019, doi: 10.1016/j.ijggc.2018.12.019.
- [37] Institute for Sustainable Process Technology, « Power to Ammonia ». 2017, [En ligne]. Disponible sur: <http://www.topsectorenergie.nl/sites/default/files/uploads/Energie%20en%20Industrie/Power%20to%20Ammonia%202017.pdf>.
- [38] IRENA, « Hydrogen from renewable power ». IRENA, sept. 2018, [En ligne]. Disponible sur: <http://www.irena.org/publications/2018/Sep/Hydrogen-from-renewable-power>.
- [39] SHELL, « SHELL Hydrogen Study, Energy of the Future? Sustainable Mobility through Fuel Cells and H2 », 2017.
- [40] Hydrogen Council, « Hydrogen scaling up, A sustainable pathway for the global energy transition », nov. 2017. [En ligne]. Disponible sur: <http://hydrogencouncil.com/wp-content/uploads/2017/11/Hydrogen-scaling-up-Hydrogen-Council.pdf>.
- [41] International Energy Agency (IEA), « Renewable Energy For Industry, From green energy to green materials and fuels ». 2017, [En ligne]. Disponible sur: https://www.iea.org/publications/insights/insightpublications/Renewable_Energy_for_Industry.pdf.

CHAPTER I

Task force: Power-to-Hydrogen and Hydrogen-to-X pathways: Clearing the Definitions from ambiguities

Authors: Robert R. Dickinson¹, Paul Lucchese², Christine Mansilla², Olfa Tlili², Sheila Samsatli³, Denis Thomas⁴, Francesco Dolci⁵, Eveline Weidner⁵, Nikolaos Lymperopoulos⁶, Nouri John Samsatli⁷, Marcel Weeda⁸, Alain Le Duigou², Pierluigi Mancarella⁹

Affiliations:

(1) Hydricity Systems Australia; and University of Adelaide, Centre for Energy Technology, Adelaide, Australia, robert.dickinson@hydricity.com.au

(2) CEA, Université Paris Saclay, Gif-sur-Yvette, France christine.mansilla@cea.fr

(3) Dept. of Chemical Engineering, University of Bath, Bath, UK, s.m.c.samsatli@bath.ac.uk

(4) Hydrogenics Europe N.V. Oevel, Brussels, dthomas@hydrogenics.com

(5) JRC - Energy, Transport and Climate, EC Petten, The Netherlands, eveline.weidner@ec.europa.eu francesco.dolci@ec.europa.eu

(6) Fuel Cells and Hydrogen Joint Undertaking (FCH JU), Brussels, Belgium, nikolaos.lymperopoulos@fch.europa.eu

(7) Process Systems Enterprise, London, UK, n.samsatli@psenterprise.com

(8) Energy Transition Advisory Group, Energy Research Centre of the Netherlands (ECN), Amsterdam, The Netherlands, weeda@ecn.nl

(9) Department of Electrical and Electronic Engineering, The University of Melbourne, Australia; and School of Electrical and Electronic Engineering, The University of Manchester, UK, pierluigi.mancarella@unimelb.edu.au

Key messages

- This paper specifically identifies the main pathways and interconnections in a way that overcomes the ambiguities inherent in the term “Power-to-Gas”.
- In turn, this provides solid and easier to understand foundations for building legal and regulatory frameworks for new business opportunities along the lengths of the numerous pathways from supply to consumption.

Abstract

Energy systems are evolving rapidly around the world, driven mainly by CO₂-e reduction targets. This has led to opportunities for integrated low carbon electricity-and-fuel systems founded on large scale “Power-to-Hydrogen, Hydrogento-X” (PtH-HtX). Power-to-Hydrogen (PtH) refers to large scale electrolysis. Hydrogen-to-X (HtX) refers to a range of high value products and services. If these pathways start with low-carbon electricity, then the fuel consumed at the downstream end also low-carbon. Use of intermittently low valued power lowers all production costs. This paper specifically identifies the main pathways and interconnections in a way that overcomes the ambiguities inherent in the term “Power-to-Gas”. In turn, this provides solid and easier to understand foundations for building legal and regulatory frameworks for new business opportunities along the lengths of the numerous pathways from supply to consumption.

Key words

- Energy markets
- Low carbon fuels
- Fuel cells
- Hydrogen storage
- Load management
- Power-to-gas

Introduction

Energy systems are rapidly and substantially changing around the world due to a variety of factors [1-8]:

- Increasing demand for energy worldwide due to globalization and emerging and developing countries;
- Increasing share of renewable electricity production;
- GHG / Carbon dioxide equivalent (CO₂-e) emissions reduction targets;
- Local pollution constraints;
- Deregulation in the energy system, allowing new industries and technologies to enter the market;
- Energy security constraints and system reliability requirements;
- Decentralisation of energy production system (both fuel and electricity).

The balancing of the electricity grid is becoming increasingly challenging with increasing proportions of renewable energy production. Solutions such as transmission super-grids and interconnectors, energy storage ('electrical power to storage to electrical power', (PtStP)), smart grids and demand management, and back-up capacity implementation can certainly support the above transition. However, fundamentally new measures are expected to be needed to manage the grid as proportions of renewable energy sources continue to increase monotonically. Further, the need for decarbonizing the whole energy system, including transport, needs to be considered, as does the difficulties and opportunities from dealing with the requirements in heavy industries. Power-to-hydrogen (PtH) system components thus clearly become part of the broader picture.

Hydrogen production via electrolysis makes it possible to quickly adjust the power consumption: electrolyzers can indeed reach full load operation within a few minutes, even a few seconds [9]. They can also decrease power consumption in the sub-second time-frame and thus provide frequency control ancillary services. Another key advantage relative to PtStP technologies is that whereas PtStP just time-shifts the electricity grid balancing challenge, PtH takes the excess renewable power out of the electricity grid once and for all is expected to have benefits under many conditions. Accordingly, hydrogen production is expected to be economically and technically attractive way to contribute to power systems management.

In this paper we use "low carbon" as follows: Electrolysis is operationally low CO₂-e only if the inherited CO₂-e from power used as input to the electrolysis plant is less than the CertifHy benchmark of 36.4 gCO₂-e / MJ of hydrogen produced [11]. Similarly, while "renewable electricity" can in general refer to a broad collection of energy harvesting technologies, for Task 38 purposes it refers to the two dominant (for

economics analysis purposes) technologies of wind and solar power.

The “Power-to-hydrogen” (PtH) concept means that once hydrogen is produced from low carbon electricity, a potentially large portfolio of uses is possible. Applications across diverse sectors include transport, blending with natural gas, and PtStP. Additional products and services include the general business of merchant hydrogen for energy or industry, and provision of ancillary services to power networks. At large scales, PtH can also facilitate deferral of upgrades to distribution and transmission network components.

Accordingly, the primary objective of this paper is to present the “Power to Hydrogen - Hydrogen to X” as broadly as space permits in this context. Our broad approach results in a more rigorous analysis foundation than the “Power-to-Gas” concept, which is specific when taken literally, as well as completely general if interpreted to mean “anything”. Each pathway is defined and presented in sufficient detail to understand how each opportunity fits into the overall integrated system.

The limits of the power-to-gas concept

Producing hydrogen from electricity and then mixing hydrogen directly with natural gas, or synthesizing methane by reacting hydrogen with carbon dioxide and then injecting the methane into the natural gas grid, are two key options that are sometimes termed as “Power-to-Gas” [12,13]. However, the “Power-to-Gas” concept is rarely properly and precisely defined. In fact, in the literature Power-to-Gas can refer to power to hydrogen for injection in the natural gas network, or for a range of different applications, sometimes even including fuel for mobility. Further, Power-to-Gas sometimes exclusively refers to renewable power to hydrogen to gas. At other times this term is used to refer more generally to “excess” or “surplus” power. In yet other instances the term refers to producing hydrogen from power without any quantitative specificity of the CO₂-e inherited from the electricity. To overcome these ambiguities and lack of semantic precision, Task 38 is instead promoting the phrase “Power-toHydrogen and Hydrogen-to-X (PtH-HtX)”. This keeps “hydrogen” at the center and thus emphasizes its flexibility as an energy carrier and an input industrial chemical production. It also ensures that the monetary value of “gas” does not dominate the perceived value of the processes being investigated. The next section presents an enumeration of pathways from intermittently low value power to high value products and services.

Screening the “power-to-hydrogen and hydrogen-to-x” pathways

A. The common step: Power-to-Hydrogen

The common component of all “PtH-HtX” pathways is the Power-to-Hydrogen step.

Hydrogen from electrical power uses electrolysis: a process that until recently has been only deployed at small scales, but 100+ MW systems are now realistic and can be expected to be deployed within a few years. Electrical energy is used to split water into hydrogen and oxygen.

Task 38 will review the roles of all electrolysis technologies, primarily: 1) alkaline and 2) proton exchange membrane (PEM), each of which are allocated a full chapter each in [8]. Co-electrolysis [14] refers to the co-production of both hydrogen and carbon monoxide from water and carbon dioxide, from which hydrocarbon fuels can be synthesized. High temperature electrolysis uses cogenerated heat from power production to increase the efficiency of the electrochemical reaction.

The key motivation for developing PtH-HtX pathways is to in turn develop cost effective decarbonization of both the power and fuel sectors of the energy system. Accordingly, PtH needs to be economically and environmentally competitive with other low-carbon production processes, such as emerging solar hydrogen [15] and thermo-catalytic methane decomposition [16], also known as methane cracking, potentially co-producing high purity graphite [17]. In turn, a key to the economic competitiveness of PtH is the intermittent availability of low, zero, or negatively priced electricity. Diverse types of PtH systems can be considered, namely, off-grid, on-grid, and directly connected with a renewable power source with backup connection to the grid.

B. Screening the Hydrogen-to-X pathways

With the aim of decarbonization of a complete integrated energy system covering both power and fuel, all the sectors can be targeted. The three main pathways are the transport sector, the industry sector, and the energy sector (power, gas and heating/cooling).

For the transport sector, hydrogen offers diverse pathways for decarbonization. Hydrogen can be used in fuelcells in vehicles, as either the only source of electricity to the electric drive train and any onboard batteries for regenerative braking, or as range extension to plugin battery electric vehicles [18]. Low-carbon hydrogen can also be an input to synthetic liquid fuel production. Similarly, synthetic and biomass sourced hydrocarbon fuel production can be enhanced by using low carbon hydrogen [19,20,21]. Low carbon synthetic fuels are particularly attractive for aviation. Another pathway for the transport sector is the production of synthetic gas fuels, where hydrogen is reacted with carbon dioxide to generate synthetic methane. Again, given that decarbonisation is the key motivation, the life-cycle balance of these systems needs to review with due diligence.

Industrial chemical technologies use hydrogen across many segments. The two major examples are hydrocarbon refineries, and ammonia for fertilizers. Together they represent over three quarters of global hydrogen demand [22]. Most hydrogen consumed to date by these industries has been produced using emissions-intensive steam methane reformation. Other carbon intensive production methods include coal gasification and oil cracking. Clearly, providing low carbon hydrogen with PtH would decrease the carbon footprint of these industries.

Finally, the versatility of low carbon hydrogen can make it a unique energy carrier for contributing to the decarbonisation of the entire energy sector in the broadest sense: power, fuel, and heating/cooling.

After having been generated from low carbon power, hydrogen can be used to regenerate clean electricity through fuel cells or gas turbines. Power production from hydrogen is particularly promising for off-grid applications (e.g. supply of remote communities and back-up power). But for grid-connected applications, a very large difference in power buy/sell price is required for PtHtP to be competitive.

Low carbon hydrogen can contribute to decarbonizing gas supply through blending. Two options are open. The first option is to directly blend hydrogen with natural gas in the natural gas grid. The amount of hydrogen that can be directly injected is limited. The second option is to inject synthetic methane produced from methanation, in which low carbon hydrogen is reacted with carbon dioxide (or also in principle, carbon monoxide). The scale of this second option is unbounded with respect to proportions injected.

Finally, hydrogen can also be used to for heating and cooling, and for combined heat and power (CHP) applications.

A visualization of the main PtH-HtX pathways with interconnections from low carbon intermittently low valued electricity to (potentially) high valued products and services, is presented in Figs.1 and 2.

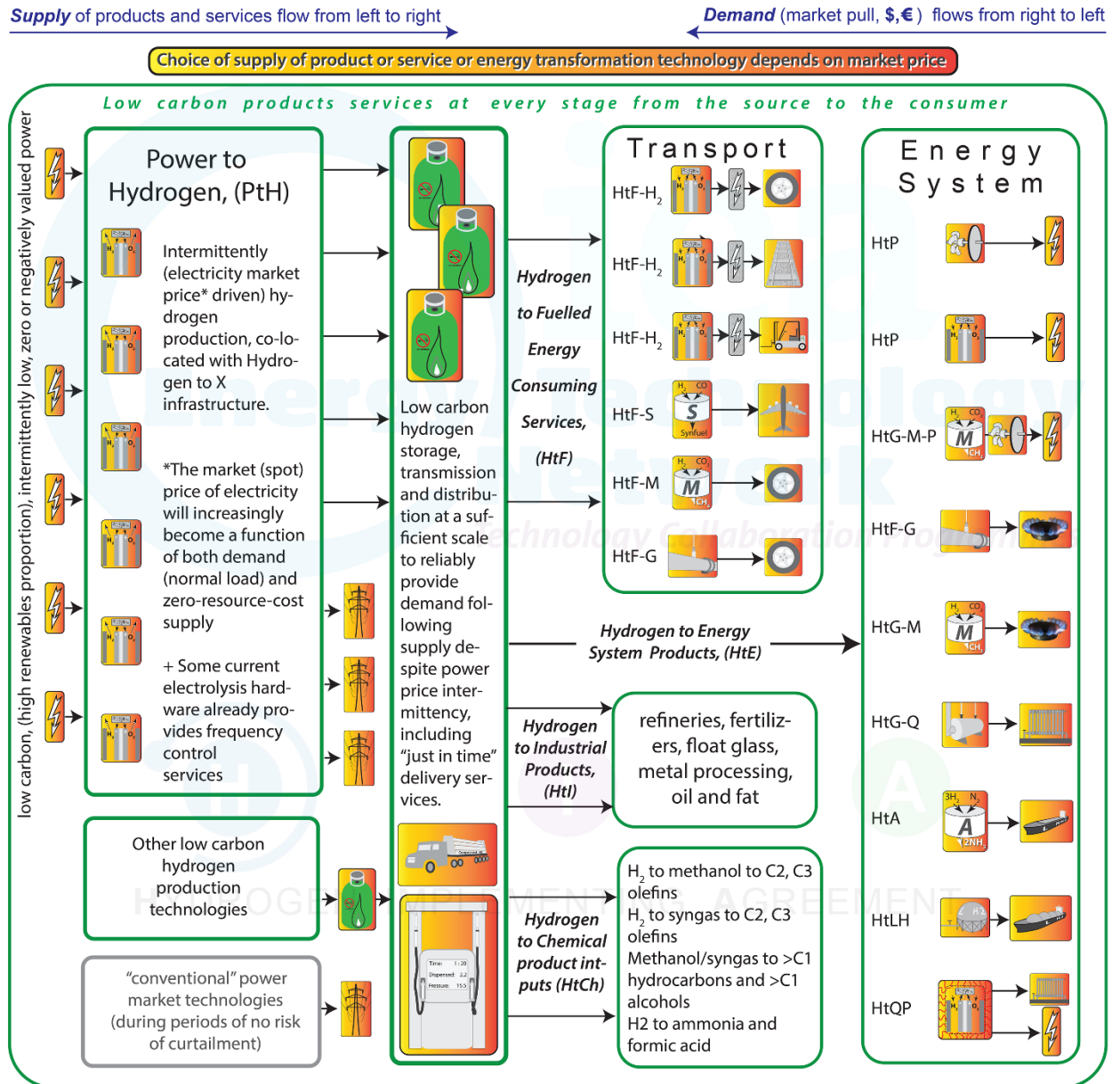

Figure 1: PtH-HtX: Enumeration of the main pathways from low carbon, intermittently low valued power to high value products and services

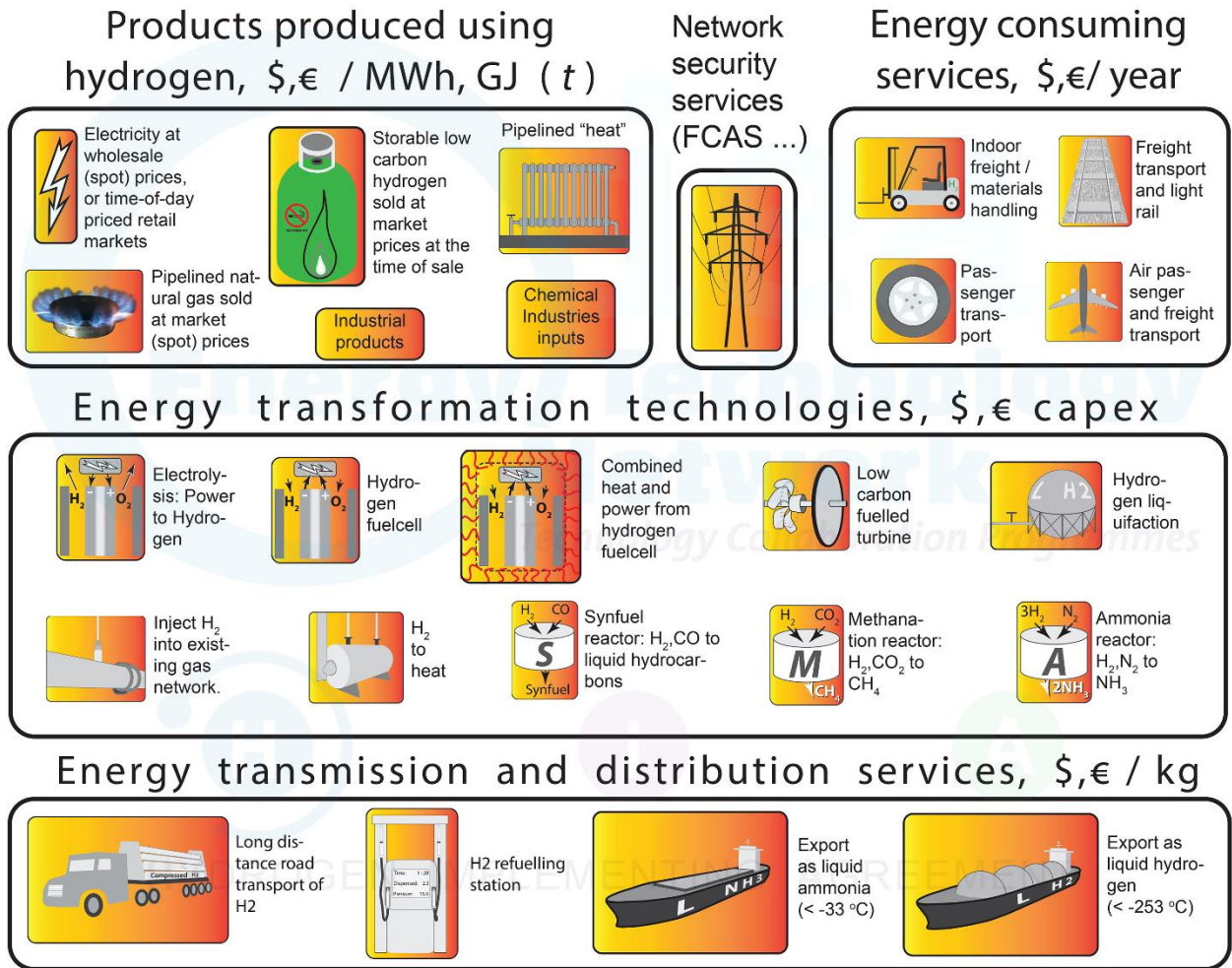

Figure 2: Pth-HtX: Icons legend of products, services, and energy transformation technologies

C. Expanding the value chain via the provision of ancillary services

As also presented in Figs. 1 and 2, extra revenues from PtH could potentially be obtained by providing system support services to the grid, in particular "Frequency Control Ancillary Services" (FCAS) (see for instance [23]) concurrently with hydrogen production. Depending on the specific power system and market, different types of ancillary services may be required which can potentially be provided by PtH. These include primary and secondary frequency response (usually with a collection of event-response times in the order of seconds, tens of seconds, and minutes), as well as different types of reserves with event-response times in the order of minutes, and tens of minutes. Recently, new fast frequency response services are also emerging (see for example [24,25]). The event-response times for these are in the sub-second time scale, particularly to address a loss of system inertia in the presence of high instantaneous

penetration of renewable electricity output, which exacerbates the frequency balance challenge. These services could be provided by electrolyzers that represent the initial step in all PtH pathways.

By providing FCAS, PtH could thus enable both the productive consumption of excess renewable power when demand is low, and grid security and reliability services that overcome the resistance by some to the ongoing deployment of increasingly high proportions of renewable power capacity.

Conclusions: PTH-HTX opportunities for the energy system and beyond

The main drivers for Power-to-Hydrogen and Hydrogen-toX is decarbonizing the energy system and productively enabling ongoing increases proportions of renewable power capacity. This paper discussed the potential role of hydrogen systems to decarbonize the transport, industry and energy sectors (power, gas, and heating/cooling). Assessing the hydrogen potential on each of the identified sector, as well as the feasibility for hydrogen to enter the identified markets was beyond the scope of this paper. The aim was rather to highlight the potential of hydrogen of being a key enabler towards a lowcarbon economy.

In this context, this paper has begun to precisely identify the main PtH-HtX pathways that can be considered, in order to overcome the ambiguities related to the phrase “Power-to-Gas”. Each pathway has been defined in order to examine the associated opportunity for the energy system. Specific attention is given to the definitions of the words and the interconnections along the main pathways, to prepare for providing inputs to future Codes and Standards committees, and to provide solid foundations for building legal and regulatory frameworks for new business opportunities. This is an ongoing work of Task 38, through the collaboration with the standardization organizations CEN (the European Committee for Standardization) and CENELEC (the European Committee for Electrotechnical Standardization).

Acknowledgements

The present work was carried out in the framework of the Task 38 of the Hydrogen Implementing Agreement of the International Energy Agency. The task is coordinated by Institute for techno-economics of energy systems (I-tésé) of the CEA, supported by the ADEME. Hydricity Systems receives support in part from the ATO/AusIndustry’s Research and Development Tax Incentive program. Pierluigi Mancarella would like to acknowledge the partial support by the UK EPSRC through the MY-STORE project (EP/N001974/1).

REFERENCES

- [1] A. Finkel, K. Moses, C. Munro, T. Effenev, and M. O’Kane, "Independent Review into the Future Security of the National Electricity Market: Preliminary Report," Canberra, Australia 2016.
- [2] International Energy Agency, "Renewable Energy: Medium-Term Market Report 2016: Market Analysis and Forecasts to 2021," 2016.
- [3] US Federal Energy Regulatory Commission, "Electric Storage Participation in Markets Operated by Regional Transmission Organizations and Independent System Operators," ed. Washington DC, 2016, p. 139.
- [4] AECOM Australia Pty Ltd, "Energy Storage Study - Funding and Knowledge Sharing Priorities," 2015.
- [5] CSIRO and Energy Networks Australia, "Electricity Network Transformation Roadmap: Interim Program Report," Canberra, Australia, 2015.
- [6] New York State, "Reforming the Energy Vision: Whitepaper March 2016," New York 2016.
- [7] AEE Institute, "Toward a 21st Century Electricity System in California," San Francisco, 2015.
- [8] T. Brown, S. A. Newell, D. L. Oates, K. Spees, and The Brattle Group Inc., "International Review of Demand Response Mechanisms: prepared for the AEMC," 2015.
- [9] A. Godula-Jopek, Ed., Hydrogen Production by Electrolysis (Sustainable / Green Chemistry. Wiley, 2015, p.^pp. Pages.
- [10] P. Lucchese, A. Le Duigou, and C. Mansilla, "Power-to-Hydrogen and Hydrogen-to-X: System Analysis of the techno-economic, legal and regulatory conditions: A new task of the IEA Hydrogen Implementing Agreement," presented at the 21st World Hydrogen Energy Conference (WHEC 2016), Zaragoza, Spain, 2016.
- [11] J. Castro, D. Fraile, F. Barth, W. Vanhoudt, M. Altmann, and W. Weindorf, "Technical Report on the Definition of ‘CertifHy Green’ Hydrogen," Brussels, Belgium 26 October 2015 2015.
- [12] S. Schiebahn, T. Grube, M. Robinus, V. Tietze, B. Kumar, and D. Stolten, "Power to gas: Technological overview, systems analysis and economic assessment for a case study in Germany," International Journal of Hydrogen Energy, vol. 40, pp. 4285-4294, 4/6/ 2015.
- [13] G. Gahleitner, "Hydrogen from renewable electricity: An international review of power-to-gas pilot plants for stationary applications," International Journal of Hydrogen Energy, vol. 38, pp. 2039-2061, 2/19/ 2013.
- [14] M. Reytier, S. Di Iorio, A. Chatroux, M. Petitjean, J. Cren, M. De Saint Jean, et al., "Stack performances in high temperature steam electrolysis and co-electrolysis," International Journal of Hydrogen Energy, vol. 40, pp. 11370-11377, 9/21/ 2015.
- [15] M. M. May, H.-J. Lewerenz, D. Lackner, F. Dimroth, and T. Hannappel, "Efficient direct solar-to-hydrogen conversion by in situ interface transformation of a tandem structure," Nature Communications, vol. 6, p. 8286, 09/15/online 2015.
- [16] A. H. Fakeeha, A. A. Ibrahim, W. U. Khan, K. Seshan, R. L. Al Otaibi, and A. S. Al-Fatesh, "Hydrogen production via catalytic methane decomposition over alumina supported iron catalyst," Arabian Journal of Chemistry.

- [17] Hazer Group Ltd, "Hazer Group Ltd Prospectus," 2015.
- [18] EU Fuelcells and Hydrogen Joint Undertaking (FCH JU), "A portfolio of power-trains for Europe: a fact-based analysis. The role of Battery Electric Vehicles, Plug-in Hybrids and Fuel Cell Electric Vehicles," Brussels, Belgium 2010.
- [19] Federal Ministry of Education and Research (BMBF), "Technologies for Sustainability and Climate Protection - Chemical Processes and Use of CO₂," Federal Ministry of Education and Research (BMBF), Germany 2014.
- [20] J. Imbach, "BtL – Biomass to Liquid: What is possible in the future?," presented at the Fuels of the Future 2012: 9th BBE/UFOP International Congress on Biofuels, International Congress Center Berlin, 2012.
- [21] B. Decourt, B. Lajoie, R. Debarre, and O. Soupa, "Hydrogen Based Energy Conversion, More than Storage: System Flexibility," Paris, France 2014.
- [22] J.-L. Durville, J.-C. Gazeau, J.-M. Nataf, J. Cueugnet, and B. Legait, "Filière hydrogène-énergie. Rapport au Madame la ministre de l'écologie, du développement durable et de l'énergie, et Monsieur le ministre de l'économie, de l'industrie et du numérique. (The hydrogen energy sector. Report to the Minister of Ecology, Sustainable Development and Energy, and the Minister of Economy, Industry and Digital Technology)," France INIS-FR--16-0808, 2015.
- [23] Australian Energy Market Operator (AEMO), "Demand Response Mechanism and Ancillary Services Unbundling - Detailed Design," 15 November 2013, 2013.
- [24] Modern Power Systems. (2016). Batteries for fast frequency response in the UK. Available: <http://www.modernpowersystems.com/features/featurebatteries-for-fast-frequency-response-in-the-uk-4944789/>
- [25] "ITM achieves rapid response electrolysis in P2G energy storage," Fuel Cells Bulletin, vol. 2016, p. 9, 1// 2016.

CHAPTER II

Subtask 2: Mapping and review of existing demonstration projects

Authors: Zaher Chehade¹, Sébastien de Rivaz², Christine Mansilla^{2*}, Paul Lucchese^{1,2,3}, Samantha Hilliard⁴, Joris Proost⁵, Darja Markova⁶, Rob Dickinson⁷, Olfa Tlili²

Affiliations:

- (1) Capenergies, France
- (2) CEA, Université Paris Saclay, Institute of Techno Economics of Energy Systems, Saclay, France;
- (3) IEA Hydrogen TCP, France
- (4) Clean Horizon, France
- (5) Université catholique de Louvain, Louvain-la-Neuve, Belgium
- (6) Energieinstitut an der Johannes Kepler Universität Linz, Austria
- (7) Hydricity Systems Australia; and University of Adelaide, Centre for Energy Technology, Adelaide, Australia

As numerous its energy applications are, hydrogen nowadays is mainly used as a chemical component in industries like ammonia production and refineries. The energy related hydrogen pathways, detailed in the previous chapter, are today mainly seen through demonstration projects. Hence, the second chapter of this document suggests a review of the PtX demonstration projects around the world. Within the framework of ST2, a workshop was organized, in which demo-project stakeholders expressed their opinions on the lessons learnt as well as the challenges of PtX pathways deployment. This chapter presents this outcome and details the results of the review.

Key messages

- 249 Power-to-X demonstrations in 33 countries were identified
- Results show that the investigated pathways are diversified
- A trend towards hydrogen industrial applications is recently attracting interest
- Balancing services are increasingly investigated via grid-connected demos

Abstract

Demonstration is a key first step towards large-scale market introduction. This chapter presents the results of a review of 249 Power-to-X demo projects in 33 countries until year 2020. Results show that the features of demonstrations have evolved significantly over the years: electrolysis capacity has increased, both for PEM and alkaline systems, and the potential for balancing and ancillary services is increasingly investigated via grid-connected demos. The scope of Hydrogen-to-X pathways has also evolved over the years, mainly to include industry applications.

Keywords

- Power-to-hydrogen
- Hydrogen-to-X
- Power-to-gas
- Renewable energy
- Demonstration
- Pilot plant

Introduction

Hydrogen systems are included in the global discussion on energy system progression [1], [2]. The application of Power-to-Hydrogen concepts for managing demand, providing seasonal storage, and the linking element between different sectors (electricity generation, gas grids, transport and industry), has attracted significant interest during the last decade [2].

Further down the value chain the hydrogen can be deployed in a large portfolio of applications – termed as “Hydrogen-to-X” (HtX). Possible applications for hydrogen are: fuel cells in transport (HtF-H₂); other transport pathways include using hydrogen to produce synfuels such as methanol or biofuels (HtF-S), or gas fuels for transport (HtF-G), “green” gas through methanation (PtG-M) or direct blending of hydrogen with natural gas (PtG-H₂) [3], in the industry e.g. refineries (HtI), heat generation (HtQ), production of chemicals (HtCh), and for re-electrification into the electricity grid or remote areas (HtP). Thereby, hydrogen interlinks the power sector to other energy intensive sectors (heat, transport, industry). This leads to consider an integrated energy system with interconnections between the energy carriers [4].

The total value chain from power generation to the usage of hydrogen in diverse applications is commonly termed “Power-to-X”. Figure 1 summarizes the different Power-to-X pathways and the respective nomenclature used in this chapter. 6 categories and 9 sub-categories are identified downstream hydrogen production (“Hydrogen-to-X” part).







Category		Acronym	Definition
Power-to-Hydrogen		PtH	Hydrogen production (and storage when requested) from low-carbon electricity either from the grid or off-grid.
Hydrogen-to-Power		HtP	Supply of electricity to the grid from hydrogen with a fuel cell or a gas turbine
Hydrogen-to-Gas		HtG-H2	Hydrogen injection in natural gas grid
		HtG-M	synthetic methane injection in natural gas grid, synthetic methane is obtained from Hydrogen from PtH through methanation processes
Hydrogen-to-Fuel		HtF-H2	Hydrogen in a vehicle to be injected in a fuel cell
		HtF-S	Hydrogen for liquid synfuel applications: liquid biofuels, synthetic liquid fuels, methanol
		HtF-G	Hydrogen for mobility through gas fuels (Hythane®, biogas, synthetic methane)
Hydrogen-to-Industry		HtI	Hydrogen from PtH and for industrial applications (e.g. Refinery)
Hydrogen-to-Heat		HtQ	Hydrogen-to-heat via H2-fired boilers; Hydrogen-to-heat and power via CHPs (fuel cells, turbine etc.)
Hydrogen-to-Chemicals		HtCh	Other pathways to industrial chemical intermediates from hydrogen which we may want to include explicitly: <ol style="list-style-type: none"> 1. H2 to methanol to C2, C3 olefins 2. H2 to syngas to C2, C3 olefins 3. Methanol/syngas to >C1 hydrocarbons and >C1 alcohols 4. H2 to ammonia and formic acid (which could also be used as alternative renewable energy storage)

Figure 1. Power-to-X pathways.

In this context, Power-to-X demonstrations are developed throughout the world to explore the potential of Power-to-X by identifying previously established knowledge and remaining concepts which should be further developed, before reaching the market.

This work carried out under the umbrella of Task 38 of the International Energy Agency's Hydrogen Technology Collaboration Programme [5], aims at reviewing all the PtH and HtX demonstrations that have been implemented around the world, to analyse the general trends and coverage, and remaining unknowns. The focus is put on the existing demonstrations, i.e. projects having a purpose of learning about the technology or system. Investigating the commercial plants is beyond the scope of this chapter. So is a prospective study on planned projects. Indeed, the ultimate goal is to propose a roadmap depicting the needs for future projects based on what was demonstrated so far (be it in technical, economic or other terms such as regulation), which will be done in collaboration with the IEA.

The following section briefly describes the methodology and selected parameters for a review of 249 demonstration projects in 33 regions (see [Appendix 1](#)). Section [Results](#) then provides the analysis of the results, focussing first on the Hydrogen-to-X part, and then on the electrolysis system (Power-to-

Hydrogen). The aim is to provide insights about the general trends, and obviously not an in-depth analysis of each demonstration project.

Methodology

This section describes the methodology and selected parameters for a review of 249 demonstration projects in 33 regions (see Appendix). As stated in the introduction, 249 demonstration projects were reviewed using a methodology developed in several steps. These 249 identified references target all demonstrators around the world, the date of which is characterized by their effective commissioning, until 2020.

The demonstration projects were first identified, using the expertise of the Task 38 members. Over 40 parameters characterizing the demonstrations were identified:

- Overview: Project location, start date, duration of demonstration, investigated pathways, consideration of services to the grid;
- Technical specifications: Type of electrolysis system, installed capacity of electrolyser, power supply scheme (on-grid, off-grid, on-grid + connection to renewable energy source (RES)), in case of renewable connection: type of power supply (e.g. all-in, excess power) and RES capacity, type of hydrogen storage (CHG, MH, CNG, salt cavern, etc.), capacity of hydrogen storage, hydrogen production mode (baseload, flexible), load factor and efficiency;
- Objectives: overall scope and demonstration objective(s); for example, technical, economic, other, and more specifically, when relevant: focus of technical objective (component, system, pathway), type of technical objective (operation validation, efficiency improvement, upscaling, etc.), type of economic objective (e.g. hydrogen production cost optimisation), type of regulatory objective;
- Results and maturity: Major technical results of the demonstrations, major economic results, technology readiness level (TRL) and market readiness level (MRL).
- Legal aspects: Specific regulations taken into account, certification scheme considered, green labeling for hydrogen production, policy support scheme, avoidance of grid fees, maximum hydrogen concentration in the natural gas grid, and incentives if any.
- Future plans: Planned future demonstrations, connection with other demonstrations, links to a roadmap, steps towards the market and messages to policy makers.

To collect the data for all the demonstrations, the demonstration coordinators were contacted directly using a template questionnaire. Also, data was collected from the literature. Over 200 references were consulted, including scientific papers, specific studies on Power-to-Gas projects, articles and news,

dedicated platforms (European Power to Gas, DOE global energy storage database, EASE, Dena, etc.) [6]-[229].

The results are detailed and discussed in the following section. Note that the information regarding each demonstration project is not always available; therefore, the demonstration numbers may not always sum up to 249. Moreover, multiple nominations may be allowed on certain indicators (such as the investigated pathways), which explains that, on the contrary, totals higher than 249 may be noticed.

Results

General outlook

249 demonstration projects were examined in 33 different countries, the HYSOLAR project being the first demonstration being identified in 1985, designed by the German Aerospace Center (DLR) and the University of Stuttgart, and implemented in two different countries (Saudi Arabia and Germany). Demonstration projects are implemented in each continent (cf. Figure 2), Europe leading the way with 202 projects, and more specifically Germany being far from the other countries with 74 demonstration plants. Demonstration projects have been installed for over twenty years, and we can notice a considerable increase from 2010 onwards.

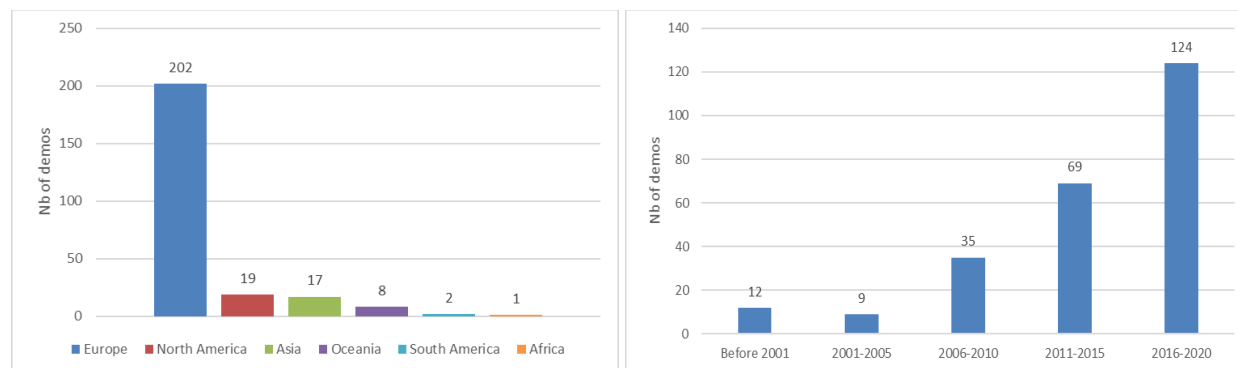

Figure 2. Geographical spread (left) and temporal evolution (right) of the number of demonstration projects

Pathway trends (“Hydrogen-to-X”)

Hydrogen is versatile. To investigate which pathways are more explored, Figure 3 shows the number of demonstrations for each of the Hydrogen-to-X (HtX) pathways being identified in Figure 2. Since each demonstration project can address more than one pathway, multiple nominations in different categories have been taken into account. Overall, the pathways that have been addressed most extensively are Hydrogen-to-Power (HtP) and Hydrogen-to-Fuel (HtF). As to the first, this is even more so if we take into account that 85% of the Hydrogen-to-heat (HtQ) projects are related to HtP as well through Combined Heat and Power (CHP) concepts. At first glance, hydrogen use for industry or chemical applications seems less investigated, with only 9% of demonstrations covering this pathway.

If we look at the temporal progression of the different pathways (cf. Figure 4), HtP and HtF have also been the pathways that have raised interest first, which contributes to explain that they appear more often among the demonstrations: they have been investigated since the beginning and still are. Hydrogen-to-Gas (HtG) applications have emerged in the early 2000's and had a boom ten years later. Most recently, the number of demonstrations on Hydrogen-to-Industry (HtI) and Hydrogen-to-Chemicals (HtCh) have risen significantly, and are now close in number to the other pathways. Since they raised interest later, it is quite logical that, overall, there are fewer of them. Since 2010, there has therefore been a marked increase in mobility applications, gas injection into networks and industrial applications.

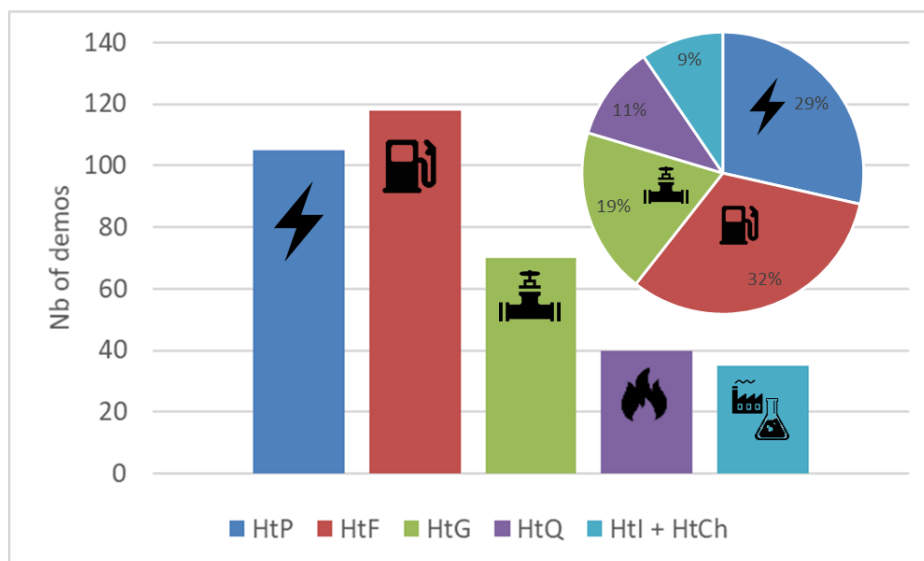

Figure 3. Share of each HtX application of the demonstration projects (multiple nomination allowed)

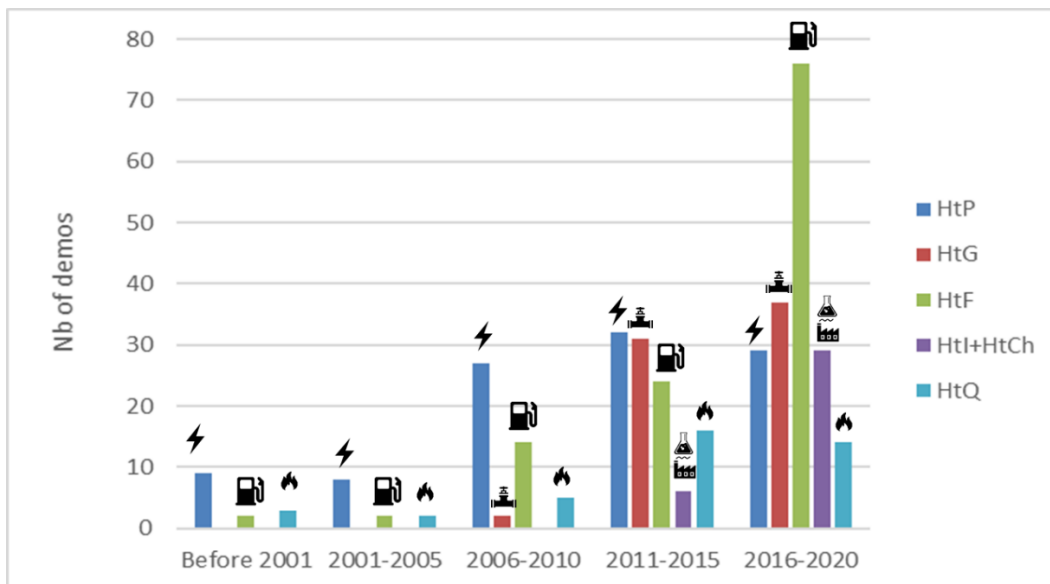

Figure 4. Evolution of HtX applications as a function of time (multiple nominations allowed)

When we consider more specifically the role of H₂ as a fuel (HtF) or a gas (HtG), it can be seen in Figure 5 that pure hydrogen as a fuel is the most investigated pathway, rather than H₂-based mixtures. It should be noted however that demonstrations on liquid synfuels only started in 2010, along with the interest in Hydrogen-to-Industry and Hydrogen-to-Chemicals as in the literature [229], making them as of today a viable alternative to pure H₂ gas for fuelling applications. With respect to Hydrogen-to-Gas, Figure 5 indicates that the injection of synthetic methane is more investigated than the direct injection and blending of pure hydrogen into the natural gas grid. This may be explained by the regulation challenges regarding the latter pathway (the allowed hydrogen concentration in the natural gas network may vary significantly from one region to another) [230]. However, this state of affairs also calls for demonstrations in order to establish the actual technical limits, push them back, and make regulation advance on this topic.

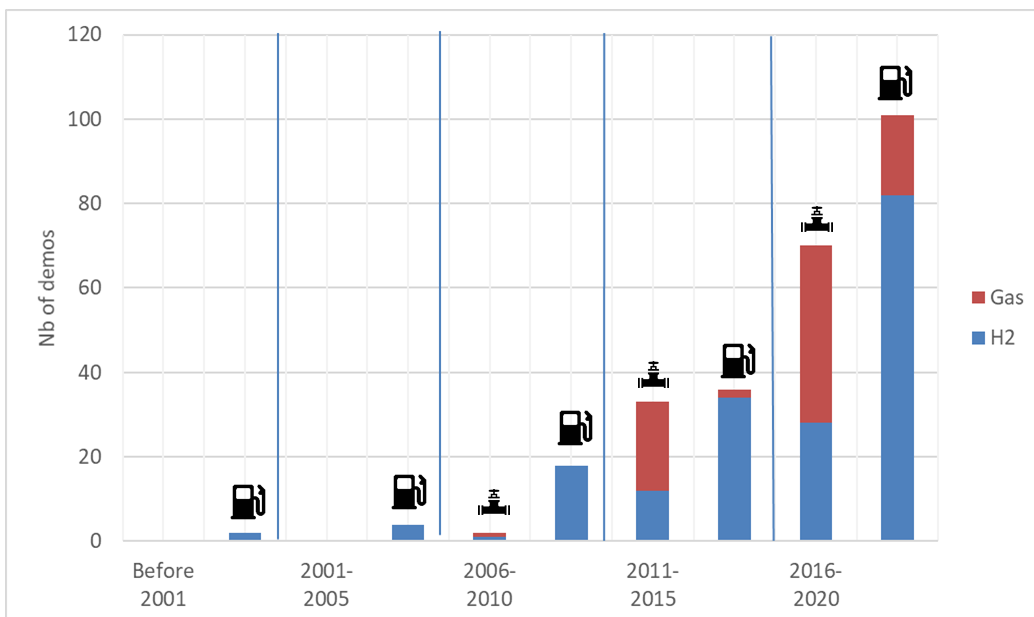

Figure 5. Time evolution of subcategories in Hydrogen-to-Fuel and Hydrogen-to-Gas

Figure 6 illustrates how the different HtX pathways are being spread throughout the world. It is striking that the 2 demo projects identified in South-America are focussing only on HtP. This corroborates in a sense to the fact that HtP has also been the very first HtX pathway being investigated. There has been so far only one demonstration project on Hydrogen-to-Industry or Chemicals in America, and none on Hydrogen-to-Heat in Asia. As to the first, Europe is clearly leading the way.

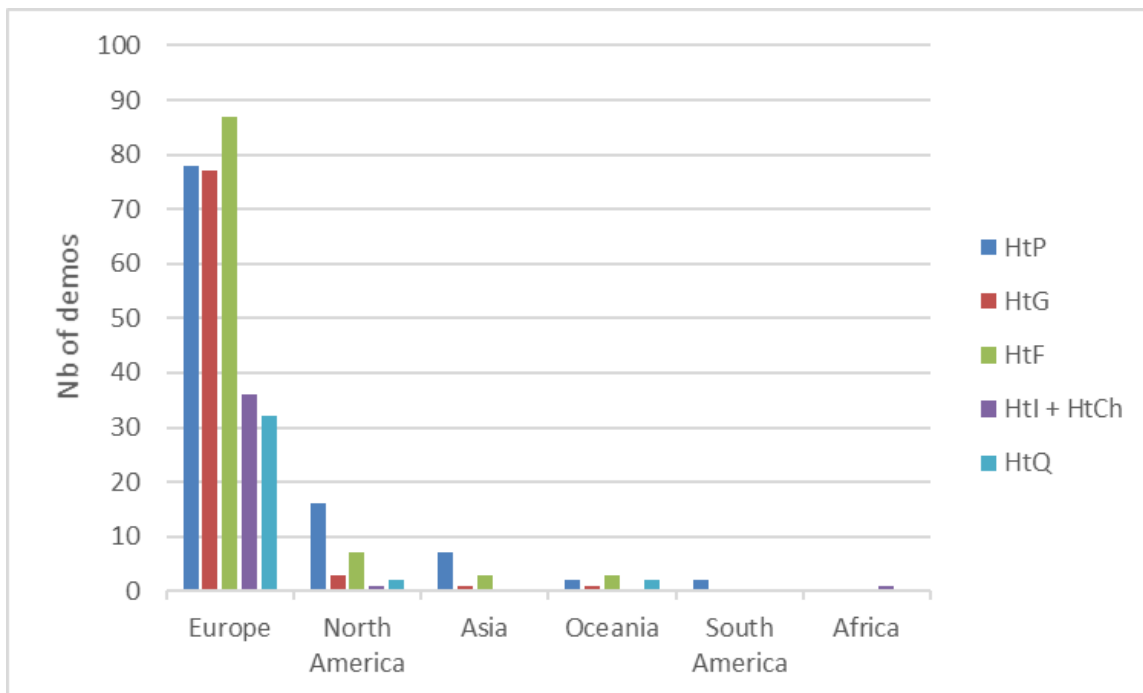

Figure 6. Geographical spread of HtX applications around the world

Finally, with respect to the multiple nominations, it can be seen in Figure 7 that in most cases demonstration projects still focus on one specific application. However, demonstrations have gradually examined multiple pathways (up to 5) within the same project. In the recent years, even if the majority of demonstrations are dedicated to single applications, the trend reveals an increasing interest in investigating hydrogen versatility in the field.

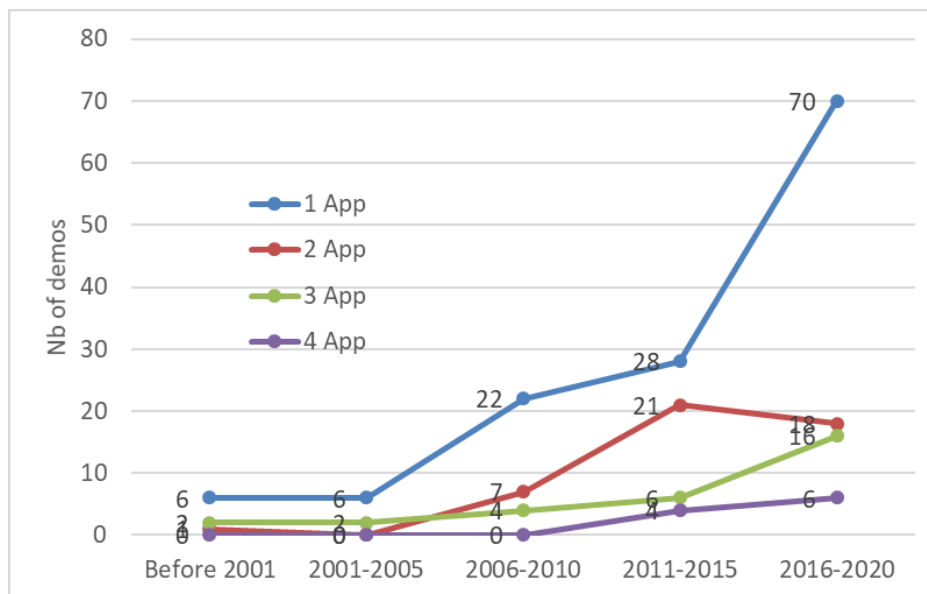

Figure 7. Time evolution of the versatility (number of HtX applications) of demonstrations

Focus on Power-to-Hydrogen

In this section, the focus is put on the demonstration upstream: the Power-to-Hydrogen part, i.e. the production (and storage when requested) of hydrogen from low-carbon electricity, either from the grid or off-grid. As the power supply scheme is a crucial topic for the production of “green” or low-carbon hydrogen, the power source of the projects was identified and classified in three main categories: on-grid supply (connected to the power grid), off-grid supply (only powered by renewable energy installed nearby or micro-grids isolated from the public power grid), and “on-grid + RES”, meaning that two connections co-exist: a direct connection with a renewable capacity, as well as a grid connection.

As shown in Figure 8 (left), the majority of demonstrations have focused so far on off-grid systems (53% vs. 28% for on-grid demonstrations and 19% for on-grid + RES). Moreover, almost all of the renewables considered were coming from wind power (cf. Figure 8 right). In recent years however, on-grid systems start to prevail (cf. Figure 9). This may be due to the fact that the pathways may be investigated with a more holistic approach (what could be the contribution of hydrogen to the energy system), including the potential input to help balancing the electric system. Indeed, 41% of the demonstration projects that started after 2015 include grid balancing services, while only 22% in the period 2011–2015, 8% between 2001 and 2015, and zero before 2001.

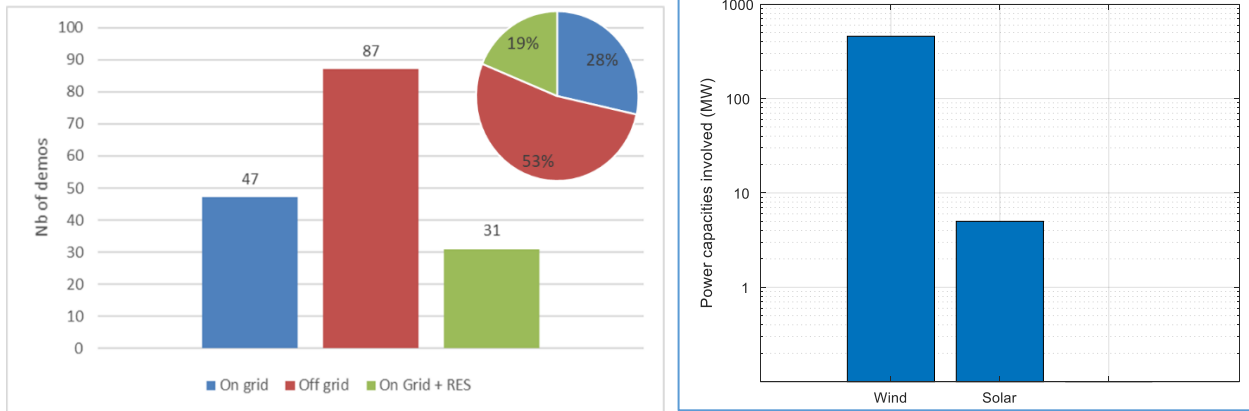

Figure 8. Power supply schemes (left) and origin of green power (right) for the P2H part of the demonstrations

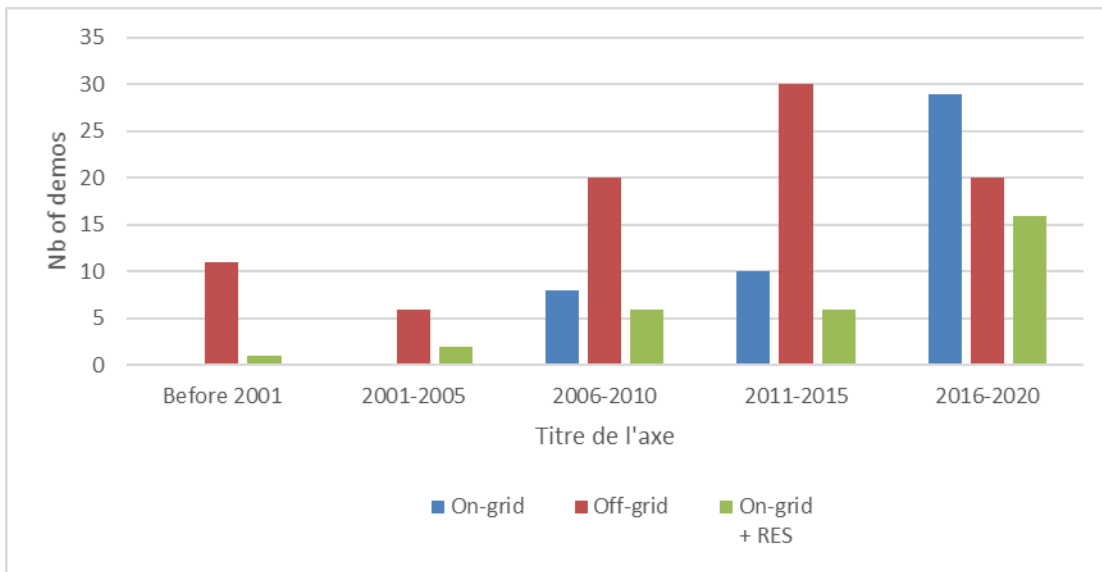

Figure 9. Evolution of the power supply schemes as a function of time

Regarding the electrolyser technology, it can be seen in Figure 10 that alkaline and PEM (Proton Exchange Membrane) electrolysers are almost as often selected (47% of the demonstrations assess alkaline electrolysers; 46% PEM). On the other hand, the total capacity installed over the years is still significantly higher for alkaline electrolysis with 184 MW installed vs 81 MW for PEM. The situation differs greatly for SOEC (Solid Oxide Electrolysis Cell) electrolysers. This technology, even though promising, is much less

mature. As a result, demonstrations are still at a different scale: SOEC are investigated in 8% of the demonstration projects, with a mere 3 MW being installed.

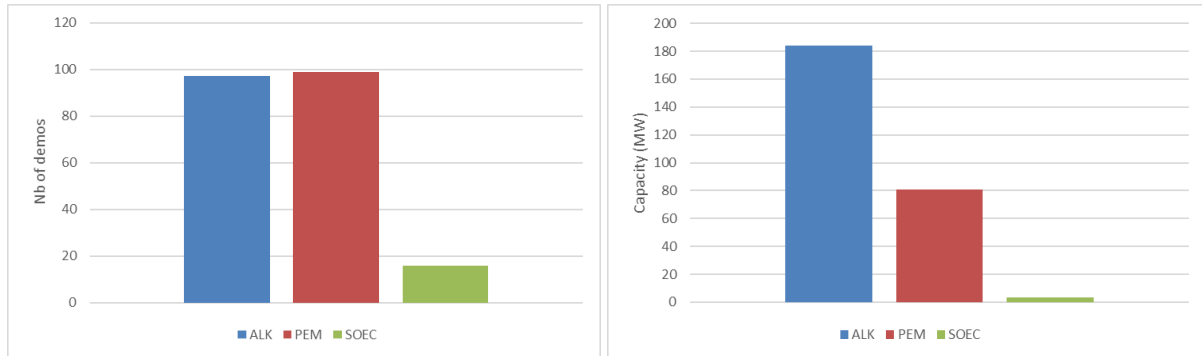

Figure 10. Number of demos (left) and total installed capacity (right) for the 3 types of electrolyser technologies

Figure 11 and Figure 12 consider in more detail the installed PtH electrolyser capacity as a function of starting date, both on a year-to-year basis (Figure 11) and cumulatively (Figure 12). Although alkaline is a more mature technology that was also installed first, very similar trends can be observed with a 5-year interval. Moreover, an upscaling phenomenon can be seen, the installed capacity per demonstration reaching several MW in years 2018 and 2019 and up to more than 10 MW in 2020 (Figure 13). The installed demo electrolysis capacity on each of the two technologies more than doubled in 2020.

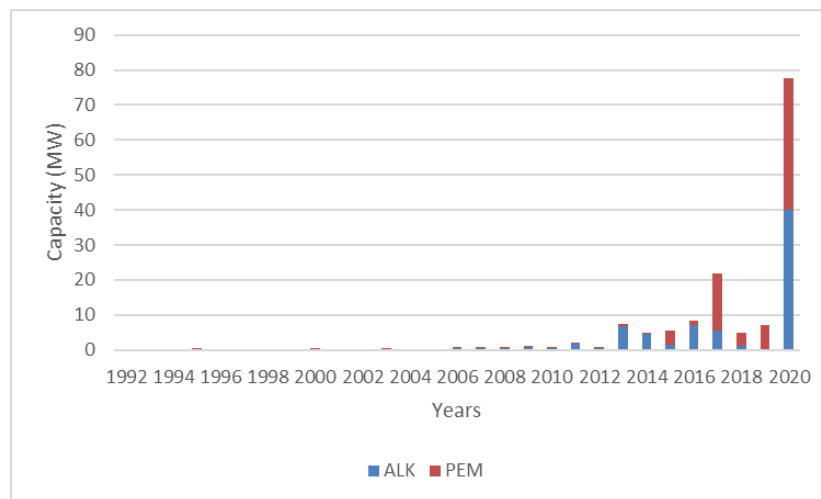

Figure 11. Total aggregated installed electrolyser capacity per year

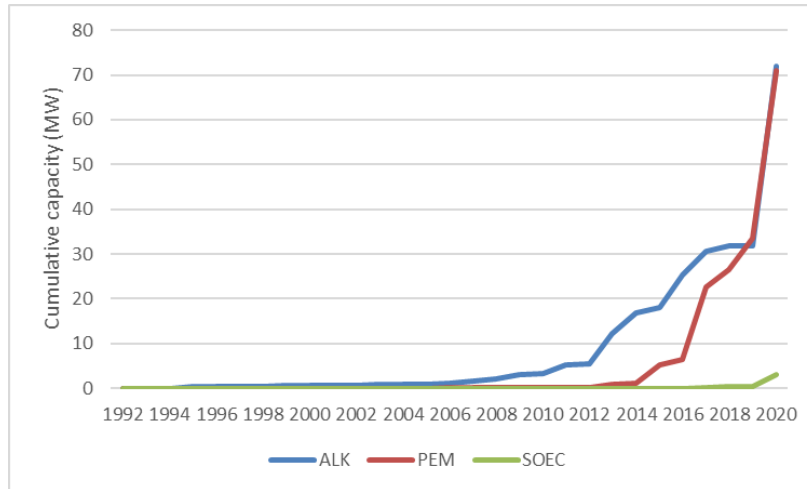

Figure 12. Comparison between the cumulative capacity of the Alkaline, PEM and SOEC technologies

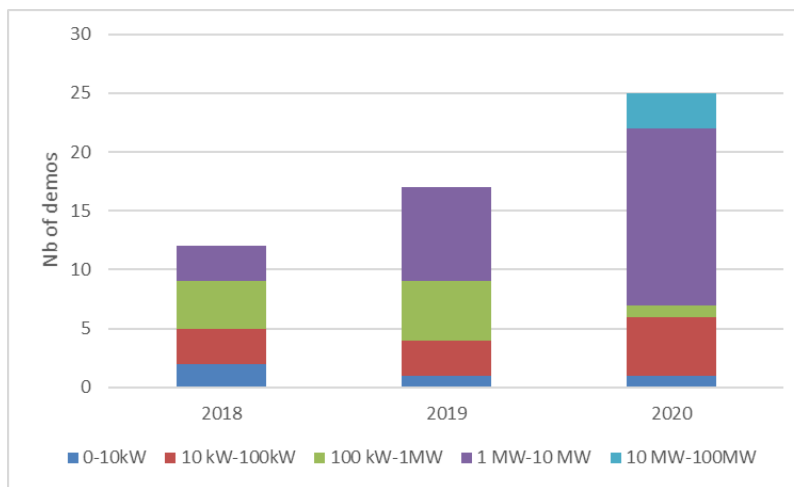

Figure 13. Total installed electrolyser capacity per demonstration project per year

The electrolysis system efficiency was also assessed from the available data. To this end, the total installed electrolyser capacity (in MW) was plotted as a function of H₂ output (in Nm³/hr), whenever available. The slope of a linear fit through such data is then inversely proportional to the system efficiency. The results are shown in Figure 14. It appears that contrary to what is often being claimed in the literature, no significant difference can be observed between alkaline and PEM systems. For ≤2 MW systems, the slopes are even identical, resulting in an average efficiency of 73%, based on a slope of 4.9 kWh/Nm³ and a HHV value of 3.54 kWh/Nm³.

Moreover, when looking at the temporal evolution in Figure 15, the efficiency values are quite scattered, and no obvious trend can be observed. Also, in the framework of Task 38 of IEA Hydrogen, an international network of experts assessed the techno-economic potential of Power-to-Hydrogen pathways. From their review of 230 internationally published studies [231], two thirds of the studies assume an average electricity consumption of 45 to 50 kWh/kg_{H2}.

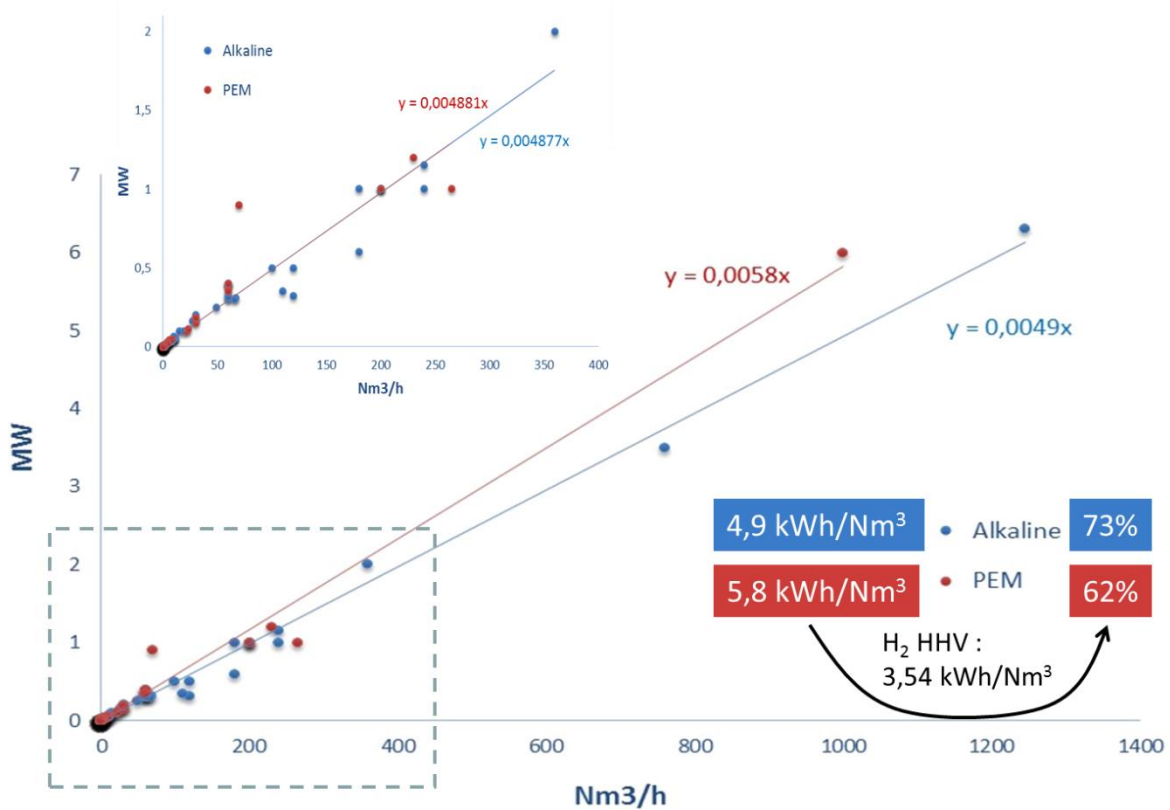

Figure 14. Installed electrolyser capacity (in MW) vs. H₂ output (in Nm³/hr) for each demo project.

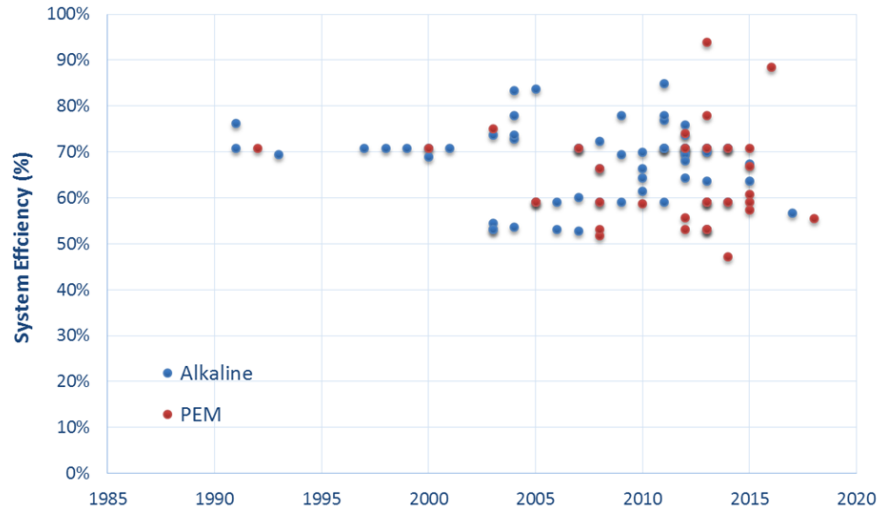

Figure 15. Evolution of Alkaline and PEM efficiencies in function of time, as calculated from Figure 14

Finally, regarding storage, 79% of the demonstration projects that provide information on this matter, include a storage option. Most of these projects considered a compressed hydrogen gas technology to store the produced hydrogen (cf. Figure 16).

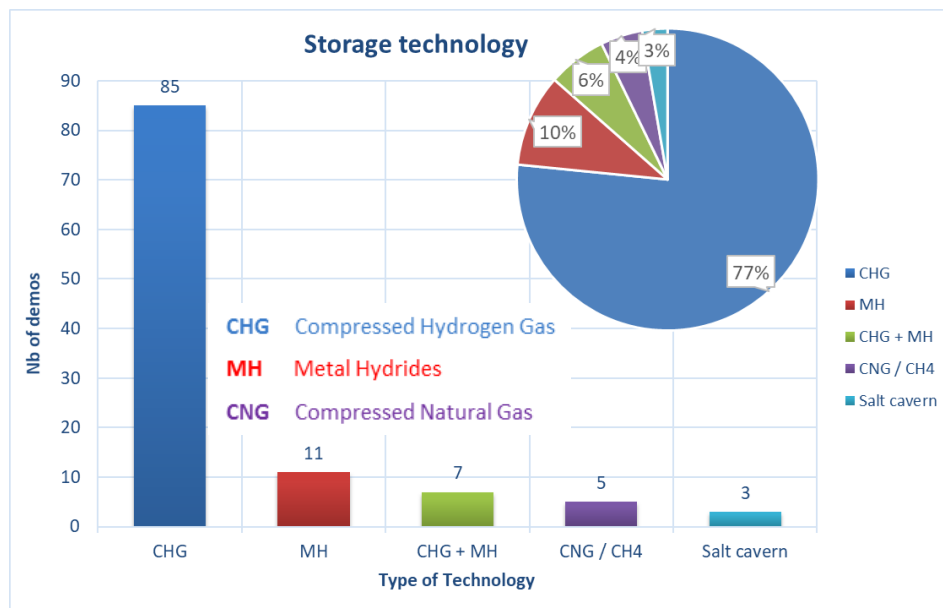

Figure 16. Demonstration storage technology

Demonstration objectives

184 demonstration projects out of 249 have explicitly mentioned their objectives. In what follows, the percentages are based on these 184 projects.

100 % of demonstrations have technical objectives, with 91% of these projects testing the operational validation, 88% evaluating the efficiency, and a mere 27% considering an upscaling plan. Since 2010, the interest in *only* the technical aspects of the demonstrations has been decreasing. Economic assessments are included in the demonstration objectives as well (cf. Table 1). 43% of the projects have an economic objective, of which only 14% consider the H₂ production cost though.

Table 1. Demonstration objectives

Demonstration start date	Share of demonstrations with technical objective(s) <u>only</u>	Share of demonstrations with economic objective(s)
Before 2001	83%	17%
2001-2005	57%	43%
2006-2010	64%	36%
2011-2015	65%	35%
2016-2020	45%	55%
Total	57% (105 demos out of 184)	43% (79 demos out of 184)

When studying the other targets of the projects, it appeared that most of the direct feedbacks received indicated a regulatory objective, while in the reviewed literature only 2% of the projects highlighted the regulatory aspect. This shows that the regulatory objectives are rather implicit subjects, yet crucial ones.

Conclusion

'Low-carbon' hydrogen (i.e. H₂ produced through low-carbon pathways) can be used by many energy-consuming services. It has a potential role to play in the electric, gas, transport, and industrial sectors. Demonstrations are a key step towards reaching the market.

A review of the Power-to-X projects in the world was carried out, identifying 249 demonstrations in 33 countries until 2020. Results show that the features of demonstrations evolved significantly in the recent years. The investigated pathways diversified, with a recent interest for industry applications. This is happening in the context of a recent and general momentum for industry applications, both at national and international levels [2], [229],[232],[233],[234]. Also, recent studies showed that only approaches favoring synergies between sectors and acknowledging sector coupling can reveal the full potential of hydrogen to decarbonize the energy system [233],[234],[235],[236],[237]. Accordingly, demonstrations consider several applications simultaneously, together with an increase of on-grid systems investigating the potential of providing system balancing to the electric grid.

This reviewing work is the first step towards an international roadmap, to be designed with the IEA, in order to better identify what are the demonstrations that are required and focus the effort on the most relevant topics, in order to reach the different markets in the near term. The increasing installed capacities of electrolysers show that we are on the way.

Acknowledgements

The present work was carried out within the framework of Task 38 of the Hydrogen Technology Collaboration Programme of the International Energy Agency. The task is coordinated by the Institute for techno-economics of energy systems (I-tésé) of the CEA, supported by the ADEME. We would also like to acknowledge the support of Capenergies for this work. One of the authors (JP) wishes to acknowledge financial support from the Public Service of Wallonia – Dept. of Energy and Sustainable Building. Special thanks to Ito Hiroshi, Yuki Ishimoto, and Federico Zenith for providing information on demo projects.

Appendix 1. list of the reviewed demonstration projects and location

Abalone Energie Nantes	FR
Aberdeen, Hydrogen bus project	UK
Adelaide Hydrogen Park South Australia (HyP SA)	AU
Aeropila	ES
Air Fuel Synthesis pilot plant	UK
AirLiquid Becancour	CA
Alzey, Exytron Null-E	DE
Ameland	NL
Baglan Energy Park Wales	UK
Balance	EU
Big HIT	UK
BioHyMe	AT
BioPower2Gas, Allendorf, Eder	DE
BOEING (rSOC Demonstrator)	US
Carbazol pilot plant, University of Erlangen-Nürnberg	DE
Carbon2Chem	DE
CEC Denizli Turkey	TR
CELBICON	EU
CEOG	FR
Cerro Pabellón Microgrid 450 kWh Hydrogen ESS - Enel S.p.A	CL
CHOCHCO	FR
CO2Exide	EU

CO2RRECT-Niederaussem	DE
Commercial Plant Svartsengi/George Olah plant	IS
CoSin: Synthetic Natural Gas from Sewage, Barcelona	ES
CUTE and HyFLEET:CUTE, Barcelona	ES
CUTE, Stockholm	SE
DEMETER	FR
Demo Plant Agricultural University Athens	GR
Demonstration of bio-CO2 products, Bio economy+	FI
Demonstration plant Kuala Terengganu, Malaysia	MY
Dietikon Hybrid Power-to-Gas Plant	CH
Direktmethanisierung von Biogas im Technikumsmaßstab	DE
DNV Kema/DNV GL	NL
Don Quichote	BE
DRI CO2 recycling	US
DTE Energy Hydrogen Technoly Park, Southfield Michigan	US
Dubai Green Hydrogen Demonstration	AE
DVGW-EBI KIT - Demo-SNG	DE
ECTOS	IS
EE-Methan aus CO2	AT
Eichhof - 1st step	DE
Eichhof - 2nd step	DE
Ekolyser (R&D)	DE
El Tubo	ES

ElectroHgena	FR
ELECTROHYPEM	EU
ELY4OFF	EU
ELYGRID (R&D)	EU
Emden I Biogas upgrading	DE
Enbridge P2G toronto	CA
EnBW H2 station, Stuttgart	DE
Energiepark Mainz	DE
Energy Park BAD LAUCHSTÄDT	DE
Energy Valley, Delfzijl	NL
ENGIE-Anglo American project	ZA
EON PtG plant Falkenhagen	DE
EON PtG plant Hamburg-Reitbrook	DE
E-THOR	NL
ETOGAS, Solar Fuel Alpha-plant 250 kW, ZSW	DE
ETOGAS, Solar Fuel Alpha-plant mobile device, ZSW	DE
ETOGAS, Solar Fuel Beta-plant AUDI, Werlte (Audi e-gas)	DE
Etzel, Salt caverns	DE
Eucolino Schwandorf	DE
FaHyence	FR
Fife, Levenmouth Community Energy Project	UK
FIRST - Showcase II	ES
FIRST project, INTA facility	ES

Foulum Demonstration plant	DK
Freiburg solar house	DE
FReSMe	SE
Fronius Energy Cell, self-sufficient house	AT
Fronius HyLOG-Fleet (Hydrogen powered Logistic System)	AT
GenHyPEM (R&D)	EU
Gösgen hydropower plant	CH
Green Ammonia Harwell in Oxford & Fukushima	UK
Green Natural Gas	DK
Greenhouse heating, solar-H ₂	IT
Grenzach-Wyhlen ZSW (Zentrum für Sonnenenergie- und Wasserstoff-Forschung Baden-Württemberg)	DE
GRHYD (Hythane)	FR
GRHYD (inj in NG grid)	FR
Grimstad Renewable Energy Park	NO
GrInHy	DE
H&R electrolysis to refinery	DE
H ₂ from the sun, Brunate	IT
H ₂ research center BTU Cottbus	DE
H ₂ BER (Berlin airport)	DE
H ₂ FUTURE	AT
H ₂ Herten	DE
H ₂ KT - Hydrogen Energy Storage in Nuuk	GL
H ₂ Move, Fraunhofer ISE	DE

H2ORIZON	DE
H2SusBuild / RES-H2	GR
Halcyon Power in Mokai	NZ
Haldor Topsoe - El-Opgraderet Biogas	DK
Haldor Topsoe - El-Opgraderet Biogas II	DK
Hamburg - Schnackenburgallee	DE
Hamburg Hafen City, CEP	DE
Hanau, Wolfgang Industrial Park	DE
HARI project, West Beacon Farm	UK
HARP System, Bella Coola	CA
Hassfurt	DE
Hawaii Hydrogen Power Park (phase 2)	US
Hebei- China	CN
Hebei Jiantou Yanshan (Guyuan) Wind Energy	CN
HELMETH	DE
Hidrolica, Tahivilla	ES
Hitachi Zosen/CO2 Conversion to Methane Project	TH
HPEM2GAS (R&D)	DE
HRS CMB	BE
HRS Wuppertal	DE
HyBALANCE	DK
Hybrid energy storage system NFCRC, California	US
Hybrid Power Plant Enertrag, Prenzlau	DE

HYBRIT	SE
Hychico, Comodoro Rivadavia	AR
HyCycle - Center for renewable H2 (R&D)	DK
Hydepark	TR
HyDeploy	UK
Hydrogen Island Bozcaada	TR
Hydrogen mini grid system Yorkshire (Rotherham)	UK
Hydrogen village Burgenland	AT
Hydrogen Wind Farm Sotavento	ES
HyFLEET:CUTE, Amsterdam	NL
HyFLEET:CUTE, Hamburg	DE
Hygreen Provence	FR
HYLINK, Totara Valley	NZ
HyNor Lillestrøm, Akershus Energy Park	NO
HYPOS (Leipzig)	DE
HYRES	GR
HySeas III	UK
Hysolar in Nieuwegein	NL
HySolar test bed Riyadh (R&D)	SA
HYSOLAR, Stuttgart	DE
HyStock	NL
HyWindBalance, Oldenburg	DE
Infinity-1	DE

INGRID	IT
IRENE System	CA
ITHER	ES
Jupiter 1000	FR
KEROSyN100	DE
Kopernikus Project	DE
Laboratory Plant HRI Quebec	CA
Laboratory Plant Stralsund	DE
Laboratory System at IFE Kjeller	NO
Lam Takhong Wind Hydrogen Hybrid Project- EGAT	TH
LastEISys (R&D)	DE
Laufenburg e-fuel plant	CH
Leuchtturmprojekt Power-to-Gas Baden-Württemberg	DE
Lingen refinery	DE
MEDLYS, Medium temperature water electrolysis (R&D)	DK
MEFCO2	DE
MEGASTACK	EU
MeGa-stoRE	DK
MeGa-stoRE Optimising and Upscaling	DK
MethQuest	DE
METHYCENTRE	FR
Mhyrabel Project	FR
MicrobEnergy GmbH, Schwandorf	DE

MicroPyros	DE
Minerve, Nantes	FR
Morbach	DE
MULTIPLHY	NL
MYRTE	FR
NEDO kofu city, Yamanashi Prefecture	JP
NEMO	FI
New zealand Matiu/Somes Island	NZ
NEXPEL (R&D)	NO
NOVEL	EU
OptFuel	AT
P2G-Biocat	DK
PHOEBUS	DE
Pilot & Demo PtM HSR, Rapperswil	CH
Ports of Auckland	NZ
PostBus Hydrogen bus, Brugg, aargau CHIC	CH
Power to flex	DE
Primolyzer (R&D)	DK
PtG-Elektrolyse im MW-Maßstab (R&D)	DE
PURE Project, Unst	UK
PUSHY (LASHY)	FR
PUSHY (OSSHY)	FR
PVFCSYS Agrate	IT

PVFCSYS Sophia Antipolis	FR
RABH2	UK
Raglan Nickel mine	CA
Ramea Wind-Hydrogen-Diesel Project	CA
Redlands Renewable Hydrogen Plant	AU
REFHYNE	DE
REFLEX	IT
Regenerativer Energipark Ostfalia/hybrid renewable energy park (HREP)	DE
RegEnKibo, Kirchheimbolanden	DE
Regio Energie Solothurn/Aarmat hybrid plant	CH
Remote Agkristo Greece	GR
Remote Ambornetti Italy	IT
Remote Froan Islands Norway	NO
Remote Ginostra Italy	IT
RENERG2	CH
RENOVAGAS	ES
RES2H2 Gran Canaria	ES
RESelyser (R&D)	EU
RE-storage	EU
Reussenköge	DE
RH2 WKA	DE
RHETICUS	DE
Rostock, Exytron Demonstrationsanlage	DE

Rostock-Laage APEX	DE
Rotterdam power-to-gas	NL
Rozenburg	NL
RWE PtG plant Ibbenbüren	DE
Salzgitter Clean Hydrogen, Linde and Avacon	DE
SAPHYS, ENEA	IT
Sarawak	MY
Schatz Solar Hydrogen Project	US
SEE / Storage of electric energy	DE
Sir Samuel building Griffith Center, Brisbane, Australia	AU
Small Scale Renewable Power System DRI (Desert Research Institute)	US
SoCalGas/Southern California Gas	US
Solar-H2 Taleghan	IR
SOLETAIR	FI
Soma IHI Green Energy Center	JP
SPHYNX, R&D	FR
Stand-alone power system, Neo Olvio of Xanthi	GR
Store&Go - Germany	DE
Store&Go - Switzerland	CH
Store&Go, Troia Italy	IT
Sunfire PtL demo "Fuel1"	DE
SWB Project, Neuburg vorm Wald	DE
SYNFUEL	DK

Tauron CO2-SNG	PL
The Hydrogen house	US
The Hydrogen office	UK
THEUS H2 Energy Storage, Takasago	JP
Thüga PtG plant Frankfurt/Main	DE
Tohoku pilot plant in 2003	JP
Towards the Methane Society	DK
Toyota Australia Hydrogen Centre	AU
Underground Sun Conversion	AT
Utsira Island	NO
Vestenskov/ Nakskov Industrial and Environmental Park, Lolland	DK
WELTEMP, Water electrolysis at elevated temperature	EU
Wind2H2 Project NREL	US
Wind2Hydrogen, HyCentA	AT
WindGas Haurup	DE
Wind-H2 stand-alone system ENEA	IT
Wind-H2 Village Prince Edward Island	CA
Wind-to-Gas Südermarsch	DE
Zhangjiakou HyPower Wangshan demonstration park Olympic Games electrolysis hydrogen project	CN
ZHAW	CH

REFERENCES

- [1] IRENA. Global energy transformation: A roadmap to 2050. Abu Dhabi: International Renewable Energy Agency; 2018. Available at: https://www.irena.org/-/media/Files/IRENA/Agency/Publication/2018/Apr/IRENA_Report_GET_2018.pdf.
- [2] IEA, The Future of Hydrogen. Seizing today's opportunities. June 2019.
- [3] Schiebahn S, Grube T, Robinius M, Tietze V, Kumar B, Stolten D. Power to gas: technological overview, systems analysis and economic assessment for a case study in Germany. *Int J Hydrogen Energy* Apr. 2015;40:4285e94.
- [4] Decourt B, Lajoie B, Debarre R, Soupa O. Leading the energy transition. Factbook. Hydrogen-based energy conversion. More than storage: system flexibility. SBC Energy Institute; 2014.
- [5] Lucchese P, et al. Power-to-Hydrogen and hydrogen-to-X: midterm appraisal of the IEA HIA task 38 accomplishments. In: Presented at the 22nd world hydrogen energy conference (WHEC 2018), Rio de Janeiro, Brazil; 2018. June 17-22.
- [6] Energieinstitut an der Johannes Kepler Universität Linz. Power to Gas: eine Systemanalyse. Markt- und Technologiescouting und analyse. Final report. 2014.
- [7] European power-to-gas platform, Available from: <http://europeanpowertogas.com/>.
- [8] Bailera, et al. Power to Gas projects review: lab, pilot and demo plants for storing renewable energy and CO₂. *Renew Sustain Energy Rev* 2017;69:292e312.
- [9] Smeets F, Thomas D. HyBALANCE: state-of-the-art PEM electrolysis paving the way to multi-MW renewable energy systems. HyBalance Inauguration Ceremony, Oevel, Belgium February 13, 2017. Available at: http://hybalance.eu/wp-content/uploads/2016/03/Hydrogenics-presentation_HyBalance-inauguration.pdf.
- [10] Gahleitner G. Hydrogen from renewable electricity: an international review of power-to-gas pilot plants for stationary applications. 2013.
- [11] Gotz M, et al. Renewable Power-to-Gas: a technological and economic review. 2015.
- [12] Vartiainen V. Screening of power to gas projects. Master's Thesis. LUT School of Energy Systems; 2016.
- [13] Thomas D. Hydrogenics. Alkaline vs PEM electrolyzers: lessons learnt from Falkenhagen and WindGas Hamburg. April 6, 2016 [Presentation] Hydrogen Days, Prague, Czech Republic.
- [14] Iskov H, Rasmussen NB. Global screening of projects and technologies for power-to-Gas and bio-SNG. Project report. Danish gas technology centre. November 8, 2013.
- [15] Kopp M, et al. Mainz Energiepark. Technical and economic analysis of the worldwide largest Power-to-Gas plant with PEM electrolysis. *Int J Hydrogen Energy* 2017;42:13311e20.
- [16] Stefansson B. CO₂-to-methanol: nordic technology with global application. November 16, 2017 [Presentation].
- [17] European Power-to-Gas platform. P2G demo project database. 2016 [Excel spreadsheet] July.
- [18] Geth F, et al. Energy storage innovation in Europe: a mapping exercise. GRID4EU October 10, 2013.
- [19] Aeropila project. Case study article. Axis Communications 2008. Available at: https://www.axis.com/files/success_stories/ss_ind_aeropila_31294_en_0806_lo.pdf.
- [20] U.K.-based Air Fuel Synthesis successfully generates gasoline out of thin air, commercialization planned by 2015. [Online] Available from: <https://tommytoy.typepad.com/tommy-toy-pbt-consultin/2013/04/scientists-successfully-generate-synthetic-gasoline-out-of-thin-air-a-one-ton-per-day-production-pla.html>.
- [21] Ulleberg, et al. Hynor Lillestrøm: a renewable hydrogen station & technology test center. WHEC; 2014.

- [22] Thanapalan K. On-board renewable hydrogen production system for hydrogen hybrid vehicles. Conference Paper; May 2012.
- [23] Thorsten Liese Dr. Experiences and results from the RWE power-to-gas-Projekt at Niederaußem site. RWE Power AG, München; November 11, 2013. Presentation.
- [24] George Olah Renewable Methanol Plant. First commercial plant. 2013. Available from: https://web.archive.org/web/20130703233732/http://cri.is/index.php?option=com_content&view=article&id=14&Itemid=8&lang=en.
- [25] The George Olah Plant. Carbon recycling international inc. Available from: https://en.wikipedia.org/wiki/Carbon_Recycling_International#cite_note-13. [31] Bio-SNG potential assessment: Denmark 2020. DGC; November 2010.
- [26] DNV GL. Power-to-Gas project in Rozenburg, The Netherlands. Report No.: GCS.15.R24613. May 31, 2015. Available at: http://images.e.dnvgl.com/Web/DNVGL/%7B24381cd9-4df3-4136-8289-a05bac049d53%7D_OG_GAS_GLOB_15Q2_PROM_Report_Power_to_Gas_project_in_Rozenburg_NL.pdf.
- [27] Held J. Small and medium scale technologies for bio-SNG production. Svenskt Gastekniskt Center Report 2013:281. Available at: <http://www.sgc.se/ckfinder/userfiles/files/SGC281.pdf>.
- [28] Repotec. Biomass CHP plant güssing. [Online] Available from: <http://www.repotec.at/index.php/95.html>.
- [29] Regan Rob. Hydrogen technology park, 2005 DOE Program review. Presentation DTE Energy May 2005. Available at: https://www.hydrogen.energy.gov/pdfs/review05/tv2_regan.pdf.
- [30] Regan R, et al. Hydrogen technology park DTE energy, progress report. 2005.
- [31] Bittner Philip. Sustainability report 2012/2013. [Brochure] Julich forschungszentrum. May 2014.
- [32] Energie Speicher. Reducing the costs with new materials [Online]. November 10, 2015. Available from: http://forschung-energiespeicher.info/en/wind-to-hydrogen/project-list/project-details//Neue_Materialien_senken_Kosten_bei_PEM_Elektrolyse/.
- [33] Dr Luis Correas. Elygrid project. Foundation for the development of new hydrogen technologies in Aragon (Spain). [Presentation].
- [34] ITM Power. 1 MW sale to ZEAG Energie AG [Online]. March 31, 2016. Available from: <http://www.itm-power.com/news-item/1mw-sale-to-zeag-energie-ag>.
- [35] DLR (German Aerospace Center). Hydrogen day well-established encounter of the industry at DLR Lampoldshausen [Online]. July 7, 2016. Available from: http://www.dlr.de/ra/en/desktopdefault.aspx/tabid-4058/6636_read-48445/.
- [36] DENA power to gas platform. WindGas Falkenhagen. [Online]. Available from: <http://www.powertogas.info/power-to-gas/pilotprojekte-im-ueberblick/windgas-falkenhagen/>.
- [37] Store&Go research project. The German demonstration site at Falkenhagen: May 09th, 2018, Methanation plant in Falkenhagen opens. [online]. Available from: <https://www.storeandgo.info/demonstration-sites/germany/>.
- [38] Andrei Dr. Zschocke. Experience with the E.ON Power to Gas demo plant. E.ON Innovation Center Energy Storage. [Presentation] Energy Storage Global Conference, Paris November 19, 2014.
- [39] Ortwein A, et al. Bioenergy RES Hybrids in Germany. IEA Bioenergy October 5, 2016.
- [40] Maria del Pilar Argumosa, Thomas H. Schucan. Fuel cell innovative remote energy system for telecom (FIRST). INTA, IEA Hydrogen Implementing Agreement. [Online]. Available at: <http://ieahydrogen.org/Activities/Selected-Case-Studies/Fuel-Cell-Innovative-Remote-Energy-System-for-Tele.aspx>.
- [41] Doris Dr. Hafenbradl. Biological methanation processes. Electrochaeta. [Presentation] European Power to Gas platform: second meeting. 2016. [Accessed 22 June 2016].
- [42] Fronius. Energy self-sufficient Family home. [Brochure].

- [43] Millet P, et al. GENHYPEM: a research program on PEM water electrolysis supported by the European commission. Ghardaïa, Algeria; October 2007. p. 27e9.
- [44] Karl H, Klug, Kwapis D. H₂erten Wasserstoffbasiertes Energiekomplementärsystem für die regenerative Vollversorgung des H₂-Anwenderzentrums h₂erten. June 18, 2013 [Presentation] Dena Jahreskonferenz Power to Gas, Berlin.
- [45] Energie park mainz webpage. [Online]. Available from: <http://www.energiepark-mainz.de/en/technology/technical-data/>.
- [46] Chalmers University of Technology. GoBiGas demonstration: a vital step for a large-scale transition from fossil fuels to advanced biofuels and electrofuels. [Online]. Available from: https://www.chalmers.se/SiteCollectionDocuments/SEE/News/Popularreport_GoBiGas_results_highres.pdf.
- [47] H-TEC Systems. Power Gap filler project. [online]. Available from: <https://www.h-tec-systems.com/en/projects/power-gap-filler/>.
- [48] NOW GmbH. Establishment of a fully integrated public hydrogen refuelling station in Schnackenburgallee, Hamburg (CEP). [Online]. Available from: <https://www.now-gmbh.de/en/national-innovation-programme/projektfinder/verkehr/h2-tankstelle-schnackenburgallee-hamburg>.
- [55] Dena Power to Gas platform. H₂-Forschungszentrum der BTU Cottbus. [Online]. Available from: <http://www.powertogas.info/power-to-gas/pilotprojekte-im-ueberblick/h2-forschungszentrum-der-btu-cottbus/>.
- [49] Hychico project website. [Online]. Available from: <http://www.hychico.com.ar/eng/hydrogen-plant.html>.
- [50] FCH JU projects. Project HyBalance. [Online]. Available from: <http://www.fch.europa.eu/project/hybalance>.
- [51] HyBalance project website. [Online]. Available from: <http://hybalance.eu/>.
- [52] MEFCO₂ project website. Methanol fuel from CO₂: synthesis of methanol from captured carbon dioxide using surplus electricity. [Online]. Available from: <http://www.mefco2.eu/>.
- [53] Cordis, Horizon. Periodic Reporting for period 2 - MefCO₂ (Synthesis of methanol from captured carbon dioxide using surplus electricity) [Online]. Available from: https://cordis.europa.eu/result/rcn/190432_en.html; 2020.
- [54] Rey Porto M, et al. H₂ production in sotavento wind farm. In: 18th world hydrogen energy conference 2010 - WHEC; 2010.
- [55] T. Vaerland et al. Grimstad renewable energy park. Agder University College. [Online]. Available from: [http://ieahydrogen.org/Activities/Selected-Case-Studies/Grimstad-Renewable-Energy-Park-\(Norway\).aspx](http://ieahydrogen.org/Activities/Selected-Case-Studies/Grimstad-Renewable-Energy-Park-(Norway).aspx).
- [56] İlhan N, Ersoz A, Çubukçuoğlu M. A renewable energy based hydrogen demonstration park in Turkey HYDEPARK. In: 18th world hydrogen energy conference 2010 - WHEC; 2010.
- [57] Maria del Pilar. Argumosa. Evaluations of Hydrogen demonstration projects. IEA HIA Task Feb 2010; 18.
- [58] Cruden A, et al. Fuel cells as distributed generation. August 2008.
- [59] Iskov H. Lolland case study: micro CHP with integrated electrolyser and gas storage 2005-2007. Danish gas technology centre. IEA HIA Task 18 Integrated systems October 2009. Available at: [http://ieahydrogen.org/pdfs/Case-Studies/Task18_Lolland_MicroCHP_\(Denmark\).aspx](http://ieahydrogen.org/pdfs/Case-Studies/Task18_Lolland_MicroCHP_(Denmark).aspx).
- [60] Fumiyuki Yamane. Hydrogen energy supply systems utilizing renewable energy. Toshiba Energy Systems & Solutions Corporation. [Presentation]. February 27, 2018.
- [61] H₂Move project specifications. [Online]. Available from: <https://www.h2move.de/technik-spezifikationen>.
- [62] RES-H₂ project brochure. H₂SusBuild consortium. National Technical University of Athens.
- [63] H₂SusBuild project website. [Online]. Available from: <http://www.h2susbuild.ntua.gr/objectives.aspx>.
- [64] Maria P. Argumosa, Tomas Cambreng. RES2H₂ Spanish site. INTA, ITC; June 2009.

- [65] Leaver Jonathan D, et al. Deployment of hydrogen technologies in New Zealand. 20th world hydrogen energy conference, WHEC 2014. South Korea: Gwangju; June 2014. p. 15e20.
- [66] Correas L, Aso I. Task 24: wind energy and hydrogen integration. In: 18th world hydrogen energy conference 2010 - WHEC; 2010. international journal of hydrogen energy 44 (2019) 27637e2765527650
- [67] D. Hustadt, O. Weinmann. Hydrogen Refuelling Station Hamburg HafenCity. 18th World Hydrogen Energy Conference 2010 - WHEC 2010.
- [68] Rupert Gammon. Measured Demonstration of Low Carbon Success: Demonstration Project of a Carbon-Neutral Energy System. [Presentation]. November 14, 2007.
- [69] Rupert Gammon. *The integration of hydrogen energy storage with renewable energy systems*. PhD Thesis. Loughborough University Institutional Repository. January 18, 2006.
- [70] Allan Grant. *Hydrogen Assisted Renewable Power (HARP) Project in British Columbia*. Powertech Labs Inc. [Presentation]. Vancouver 2010 Symposium on Microgrids.
- [71] J.D. MacLay et al. *Experimental results for hybrid energy storage systems coupled to photovoltaic generation in residential applications*. International Journal of Hydrogen Energy, 36(19). 2011.
- [72] Michael Wenske. *ENERTRAG- Hybrid Power Plant*. Enertag. [Presentation] International Hydrogen Energy Development Forum 2013 Fukuoka, 30/31.01.2013. Available from: <http://hydrogenius.kyushu-u.ac.jp/cie/event/ihdf2013/pdf/1-2wenske.pdf>
- [73] Frano Barbir. *UNIDO-ICHET's Hydrogen islands initiative, Projects Update*. [Presentation] European Union Sustainable Energy Week 22-26 March 2010.
- [74] Beermann Martin et al. *Hydrogen Powered Fuel Cell Forklifts – Demonstration of Green Warehouse Logistics*. Barcelona, Spain, November 17-20, 2013.
- [75] Fronius Energy Cell. *Storing solar energy as hydrogen*. [Brochure].
- [76] N. Lymperopoulos. *European Developments in Electrolyser Technology, Technical and Economic Outlook*. FCH JU. [Presentation] Power to Gas Conference, Antwerp, June 7, 2018.
- [77] Klaus Stolzenburg et al. *Hydrogen as a means of controlling and integrating wind power into electricity grids, the HyWindBalance project*. International Conference “Hydrogen on Islands”, 22-25 October 2008, Bol, Island of Brac, Croatia.
- [78] Massimo Bertoncini. *Power-to-Gas in Italy: INGRID and STORE&GO projects: A first-of-this-kind experience*. Engineering Ingegneria Informatica. [Presentation] Milano, May 28, 2018.
- [79] Alvin P. Bergen. *Integration and Dynamics of a Renewable Regenerative Hydrogen Fuel Cell System*. PhD thesis. University of Victoria. 2008.
- [80] T. Geer, J. F. Manwell, J. G. McGowan. *A Feasibility Study of a Wind/Hydrogen System for Martha's Vineyard, Massachusetts*. University of Massachusetts. American Wind Energy Association Windpower 2005 Conference May 2005.
- [81] ITM Power. Injection of Hydrogen into the German gas distribution grid. [Online] December 4, 2013. Available from: <http://www.itm-power.com/news-item/injection-of-hydrogen-into-the-german-gas-distribution-grid>
- [82] Energie Agentur. *Power-to-Gas in Germany and North-Rhine Westphalia (NRW): Ideas, Potential, Projects*. September 2016.
- [83] University of Corsica, Helion, CEA. *Inauguration de la plateforme de Recherche & Développement Solaire et Stockage de l'Énergie par les technologies hydrogène – MYRTE*. [Report] January 9, 2012.
- [84] Ulrich Bohn, Florian Lindner. *Power-to-Gas demonstration plant Ibbenbüren: Project description and background information*. RWE Deutschland AG. [Presentation] September 2015.

- [85] Séverine Busquet. *Étude d'un système autonome de production d'énergie couplant un champ photovoltaïque, un électrolyseur et une pile à combustible : réalisation d'un banc d'essai et modélisation*. PhD thesis. Ecole des Mines de Paris. December 15, 2003.
- [86] N. Lymberopoulos. *Hydrogen production from renewables*. September 2005.
- [87] Frédéric Gailly. *Alimentation électrique d'un site isolé à partir d'un générateur photovoltaïque associé à un tandem électrolyseur/pile à combustible (batterie H₂/O₂)*. PhD thesis. University of Toulouse. July 18, 2011.
- [88] Torgeir Nakken et al. *Utsira - Demonstrating the renewable hydrogen society*. WHEC 16 / 13-16 June 2006 – Lyon France.
- [89] P. Millet. High pressure PEM water electrolysis and corresponding safety issues. [Presentation] International conference on Hydrogen Safety (ICH_S3-09) Ajaccio, France, 16-18 September 2009.
- [90] Tapan K. Bose. *Stand-alone Renewable Energy system based on Hydrogen production*. University of Quebec.
- [91] S. Galli. *The Solar-Hydrogen SAPHYS project: Operating results*. ENEA.
- [92] Tauron group. *CCS/CCU in Tauron group*. [Presentation].
- [93] InnoEnergy. Complete CO₂-SNG installation. [Online]. Available from: <http://www.innoenergy.com/innovationproject/our-innovation-projects/co2-sng/>
- [94] Hydrogeit. HYPOS – From Storage to Distribution. [Online] December 1, 2017. Available from: <https://www.h2-international.com/2017/12/01/hypos-from-storage-to-distribution/>
- [95] HYPOS project website. [Online]. Available from: <http://www.hypos-eastgermany.de/en/>
- [96] McPhy energy. *Innovative H₂ Solutions to Move Towards Clean & Smart Territories*. European Commission JRC S3P Energy: Smart Mediterraneo. [Presentation] Bari, 23-24 June 2016.
- [97] Energetica International. *The self-sufficient house: renewable energy with storage systems*. Fronius.
- [98] MeGa-stoRE final report, project no.12006. Aarhus University. 2015.
- [99] Laurent Meillaud. Hydrogen today. *Power-to-gas: inauguration du projet GRHYD à Dunkerque*. [Online] June 12, 2018. Available from: <https://hydrogentoday.info/news/4350>
- [100] Ileana Blanco et al. *Hydrogen and renewable energy sources integrated system for greenhouse heating*. University of Bari. Journal of Agricultural Engineering 2013; volume XLIV(s2):e45. 2013.
- [101] A. Shiroudi and S. R. Hosseini Taklimi. *Demonstration project of the solar hydrogen energy system located on Taleghan-Iran: Technical-economic assessments*. World Renewable Energy Congress 2011, Linköping, Sweden, 8-13 May, 2011.
- [102] Erik Christensen. *WELTEMP Water electrolysis at elevated temperatures*. Department of Chemistry, Technical University of Denmark. [Presentation].
- [103] AFHYPAC, Ph. Boucly., Th. Alleau. *Le "Power to Gas"*. Revised by P. Malbrunot on February 2018.
- [104] Dr. Jörg Dehmel. *REFHYNE Project: 10 MW Electrolyser Rhineland Refinery, General Overview*. Shell Rhineland. [Presentation] April 2018.
- [105] Z. Khan et al. *Review on Hydrogen production technologies in Malaysia*. International Journal of Engineering & Technology IJET-IJENS Vol: 10 NO: 02. June 2010.
- [106] Øystein Ulleberg et al. *Hydrogen Demonstration Project Evaluations*. Final report for IEA HIA, Task 18, Subtask B. November 2007.
- [107] DOE Global Energy Storage Database website. [Online]. Available from:
- [108] <http://energystorageexchange.org/projects/1447>
- [109] Wikipedia. *Power-to-Gas*. [Online]. Available from: <https://de.wikipedia.org/wiki/Power-to-Gas>
- [110] Méziane Boudellal. *Power-to-Gas: Renewable Hydrogen Economy for the Energy Transition*. Walter de Gruyter GmbH & Co KG. February 5, 2018 - 226 pages. [Online] E-book. Available from:

- https://books.google.fr/books?id=3ZNdDwAAQBAJ&pg=SA7-PA40&lpg=SA7PA40&dq=Raglan+Nickel+mINE+canada+power+to+gas+hydrogen+electrolyzer&source=bl&ots=jVKI__oP3w&sig=Nco6uJDGomFyhk0ZiIVb1JReULY&hl=fr&sa=X&ved=0ahUKEwjy5ZnZy6jcAhUDgVwKHTTWcmwQ6AEIYDAK#v=onepage&q=Raglan%20Nickel%20mine%20canada%20power%20to%20gas%20hydrogen%20electrolyzer&f=false
- [111] Store & Go website. *The Swiss demonstration site at Solothurn*. [Online]. Available from: <https://www.storeandgo.info/demonstration-sites/switzerland/>
- [112] Andy Lutz et al. *Case Study: The Hawaii Hydrogen Power Park Demonstration at Kahua Ranch*. January 22, 2010.
- [113] University of Hawaii. *Final Technical Report: Hawaii Hydrogen Center for Development and Deployment of Distributed Energy Systems*. September 2008.
- [114] Hycenta. *W2H (01.01.2014-31.12.2017)*. [Online]. Available from: <http://www.hycenta.at/projekte/w2h/>
- [115] Energy innovation Austria. *Hydrogen and fuel cell technology in the energy and transport systems of the future*. February 2015.
- [116] Franz E. Leichtfried. *Wasserstoffzeugung mittels PEM-Elektrolyse: Unterbrechungsfreie Versorgung mit ultrareinem Wasserstoff aus Wasser und Strom*. Biovest GmbH. [Presentation]. 2007.
- [117] *CO2RRECT: Storing electricity while simultaneously capturing CO2*. 2013. Available from: <http://kraftwerkforschung.info/en/co2rrect-storing-electricity-while-simultaneously-capturing-co2/page/0/>
- [118] Johannes Lindorfer. *Research Studio Austria OptFuel 2-stage anaerobic digestion of biowaste combined with power-to-gas*. [Presentation] IEA Bioenergy Task 39. September 29, 2016.
- [119] University of Applied Sciences Hochschule Emden Leer. *POWER-TO-FLEX*. [Online]. Available from: <http://oldweb.hs-emden-leer.de/forschung-transfer/institute/eutec/arbeitsgruppe-umweltverfahrenstechnik/projekte-in-der-ag-umweltverfahrenstechnik/power-to-flex.html>
- [120] HPEM2GAS project website. [Online]. Available from: <http://hpem2gas.eu/results/#WP5>
- [121] AZoCleantech. *Synthetic Natural Gas from Sewage Treatment Plant*. [Online] June 12, 2018. Available from: <https://www.azocleantech.com/news.aspx?newsID=25653>
- [122] B. Simonis, M. Newborough. *Sizing and operating power-to-gas systems to absorb excess renewable electricity*. ITM Power, Sheffield, UK. August 2017.
- [123] Dena Power to Gas platform. *CO2RRECT*. [Online]. Available from: <http://www.powertogas.info/power-to-gas/pilotprojekte-im-ueberblick/co2rrect/>
- [124] Christian Buck and Sebastian Webel, Siemens. *Hydrogen from Electrolysis: The Most Versatile Fuel*. [Online] July 2, 2015. Available from: <https://www.siemens.com/innovation/en/home/pictures-of-the-future/energy-and-efficiency/smart-grids-and-energy-storage-electrolyzers-energy-storage-for-the-future.html>
- [125] HELMETH project website. [Online]. Available from: <http://www.helmeth.eu/index.php/project>
- [126] Energiforskning.dk. *El upgraded biogas*. HALDOR TOPSØE A/S. [Online]. Available from: <https://energiforskning.dk/en/node/7155>
- [127] Energiforskning.dk. *El Opgraderet Biogas II*. HALDOR TOPSØE A/S. [Online]. Available from: <https://energiteknologi.dk/node/9160>
- [128] Nvnom. *Power-to-Gas plant for Delfzijl*. [Online] April 15, 2014. Available from: <https://www.nvnom.com/homepage/power-gas-plant-delfzijl/>
- [129] A. Luque et al. *Tenth E.C. Photovoltaic Solar Energy Conference*, Proceedings of the International Conference, held at Lisbon, Portugal, 8–12 April 1991. [Online] E-book. Available from: https://books.google.fr/books?id=CKfnCAAQBAJ&pg=PA476&lpg=PA476&dq=NEMO+project+finland+hydrogen&source=bl&ots=BDZBlevcyo&sig=YQjG3gev_i-RL2ezD-

48wRSMQjY&hl=fr&sa=X&ved=0ahUKewiKtvXM67ncAhXKxoUKHRnMCLYQ6AEIQjAG#v=onepage&q=NEMO%20pr
oject%20finland%20hydrogen&f=false

- [130] FCH JU. *Project REFHYNE: Clean Refinery Hydrogen for Europe*. [Online]. Available from:
- [131] <http://www.fch.europa.eu/project/clean-refinery-hydrogen-europe>
- [132] Storengy. *Methycentre: Unité de Power-to-Gas (hydrogène et méthane de synthèse) couplée à une unité de méthanisation*. [Brochure].
- [133] Nel ASA. *Nel ASA: Enters into exclusive NOK 450 million industrial-scale power-to-gas framework agreement with H2V PRODUCT*. [Online] June 13, 2017. Available from: <http://news.cision.com/nel-asa/r/nel-asa--enters-into-exclusive-nok-450-million-industrial-scale-power-to-gas-framework-agreement-wit,c2286835>
- [134] Bjørn Simonsen. *Hydrogen infrastructure for any vehicle types*. Nel ASA. [Presentation].
- [135] HyFLEET: CUTE project website. [Online]. Available from: <https://www.global-hydrogen-bus-platform.com/Home.html>
- [136] Marie-Anne Garigue. *Power-to-Gas : McPhy livre 4 MW d'équipements de génération d'hydrogène au Hebei et conforte sa position sur les projets internationaux multi-MW*. McPhy. [Online]. Available from:
- [137] https://mcphy.com/fr/mclive/communiqués/power_to_gas_mcphy_hebei_livraison/
- [138] Stephen Crolius. *Renewable Hydrogen in Fukushima and a Bridge to the Future*. Ammonia Energy. [Online] October 19, 2017. Available from:
- [139] <http://www.ammoniaenergy.org/renewable-hydrogen-in-fukushima-and-a-bridge-to-the-future/>
- [140] RE Hydrogen electrolyzers. [Online]. Available from: <http://rehydrogen.com/OLD2/electrolyzers.html>
- [141] H2orizon project website. [Online]. Available from: <https://www.h2orizon.de/>
- [142] Thorben Andersen. *H2ORIZON: Sector coupling with wind-hydrogen*. German Aerospace Center (DLR). [Online]. Available from: <https://event.dlr.de/en/hmi2018/h2orizon/>
- [143] Jean-Philippe Defawe. *Un démonstrateur « power-to-gas » en service à Nantes*. Le Moniteur. [Online] February 9, 2018. Available from: <https://www.lemoniteur.fr/article/un-demonstrateur-power-to-gas-en-service-a-nantes.1949184>
- [144] Pour la Science journal. *L'Hydrogène au cœur de la transition énergétique*. [Online] March 2018. Available from: https://www.engie.com/wp-content/uploads/2018/05/tap_engie.pdf
- [145] Agence Nationale de la Recherche. *Résumé public du projet*. CHOCHCO project. September 2015.
- [146] Chochco project website. [Online]. Available from: <https://chochco.fr/>
- [147] Energie Innovativ. *MicroPyros GmbH - Power-to-Gas*. [Online]. Available from: <https://www.energie-innovativ.de/service-events/messetour/gestalter-der-energie-wende/gestalter-nach-regierungsbezirken/gestalter-in-niederbayern/gestalter-in-niederbayern/gestalter/Gestalter/show/micropyros-gmbh/>
- [148] MicroPyros project website. [Online]. Available from: <https://www.micropyros.de/>
- [149] Nel Hydrogen. *Nel Hydrogen Electrolyser: The world's most efficient and reliable electrolyser*. [Online]. Available from: https://nelhydrogen.com/assets/uploads/2017/01/Nel_Electrolyser_brochure.pdf
- [150] Henning G. Langås. *Large scale Hydrogen production*. Nel Hydrogen. [Presentation] «Renewable Energy and Hydrogen Export» Trondheim, Norway – March 24th 2015.
- [151] M.J. Kippers et al. *Pilot project on Hydrogen injection in natural gas on island of Ameland in the Netherlands*. International Gas Union Research Conference, Seoul, 2011.
- [152] Harm Vlap. *Power-to-Gas Demonstration Project Rozenburg*. [Presentation] Workshop Power2Gas: From Theory2Practice. November 18, 2014.
- [153] FCH JU. *Clean Hydrogen in European Cities project: Presentation of the emerging conclusions*. CHIC project. [Presentation]. June 2016.

- [154] Hydrogen Europe. *Project CHIC: Clean Hydrogen in European Cities*. [Online]. Available from: <https://hydrogeneurope.eu/project/chic>
- [155] Institut Für Energietechnik. *Power-to-Methane Demonstrationsanlage der Schweiz*. [Online]. Available from: <https://www.iet.hsr.ch/index.php?id=13510>
- [156] Hydrogen Europe. *Project NEXPEL: Next-Generation PEM Electrolyser for Sustainable Hydrogen Production*. [Online]. Available from: <https://hydrogeneurope.eu/project/nexpel>
- [157] Sintef. *NEXPEL: Leading the development of highly efficient hydrogen production*. [Online]. Available from: <https://www.sintef.no/projectweb/nexpel/>
- [158] Cordis. *PRessurized PEM electrOLYZER*. [Online]. Available from:
- [159] https://cordis.europa.eu/project/rcn/94279_fr.html
- [160] SET-Plan Information System (SETIS). *Mapping of projects, activities, resources and investments*. PROCON project. [Questionnaire]. January 2011.
- [161] Energie Speicher. *Wasserstoff-Herstellung im Megawatt-Maßstab*. [Online] April 12, 2017. Available from: http://forschung-energiespeicher.info/projektschau/gesamtliste/projekt-einzelansicht/95/Wasserstoff_Herstellung_im_Megawatt_Masstab/
- [162] *The Hydrogen Centre: The University of Glamorgan Renewable Hydrogen Research and Demonstration Centre*. Baglan Energy Park, University of Glamorgan.
- [163] RESElyser project website. *Hydrogen from RES: pressurised alkaline electrolyser with high efficiency*. [Online]. Available from: <http://www.reselyser.eu/index.html>
- [164] Cordis. *Final Report Summary - RESELYSER (Hydrogen from RES: pressurised alkaline electrolyser with high efficiency and wide operating range)*. [Online]. Available from: https://cordis.europa.eu/result/rcn/176817_en.html
- [165] Greg Jones. *Wind-Hydrogen-Diesel Energy Project*. Nalcor energy. [Presentation] September 15, 2010.
- [166] Catherine Fait. *Data Mining Techniques Applied to a Building-Integrated Hybrid Renewable Energy System*. Bachelor thesis. Ostfalia University of Applied Sciences. [Online] May 25, 2018. Available from: https://www.theseus.fi/bitstream/handle/10024/150448/Fait_Catherine.pdf?sequence=1&isAllowed=y
- [167] *Fuel cells and Hydrogen in Norway*. Fuel Cell Today. Report, January 2013.
- [168] Monika Landgraf. *Regional Generation, Use, and Storage of Power*. Karlsruhe Institute of Technology. [Online] August 31, 2015. Available from: http://www.kit.edu/kit/english/pi_2015_regional-generation-use-and-storage-of-power.php
- [169] Prince Edward Island Energy Corporation. *Canada's green province: Developing, demonstrating and implementing leading-edge renewable energy technologies*. [Presentation].
- [170] Dena Power to Gas platform. *EXYTRON Demonstrationsanlage*. [Online]. Available from: <http://www.powertogas.info/power-to-gas/pilotprojekte-im-ueberblick/exytron-demonstrationsanlage/>
- [171] Dena Power to Gas platform. *Exytron Zero-Emission-Wohnpark*. [Online]. Available from: <http://www.powertogas.info/power-to-gas/pilotprojekte-im-ueberblick/exytron-zero-emission-wohnpark/>
- [172] EXYTRON. *Une vision devient réalité: Le premier quartier résidentiel ZÉRO ÉMISSION au monde*. [Presentation] Montpellier, December 15, 2016.
- [173] Fabian Reetz. *Das Micro Smart Grid als Baustein einer zukunftsfähigen Energieversorgung*. Innovationszentrum. [Presentation] November 14, 2013.
- [174] Curt Robbins et al. *Small Scale Renewable Energy Power System with Hydrogen Combustion*. Desert Research Institute. [Presentation] NHA Hydrogen Conference, March 31, 2008.
- [175] Desert Research Institute. *Renewable Energy Hydrogen Based System for Off-Grid Applications*. [Online].

Available from: <http://www.dri.edu/editor/rec-projects/213-renewable-energy-hydrogen-based-system-for-off-grid-applications>

- [176] D. Ipsakis et al. *Energy management in a stand-alone power system for the production of electrical energy with long term hydrogen storage*. 2008.
- [177] Hydrogen house project website. *The hydrogen house*. [Online]. Available from: <http://hydrogenhouseproject.org/the-hydrogen-house.html>
- [178] Bright Green Hydrogen. *The Hydrogen Office Project (2008-2014)*. [Online]. Available from: <https://www.brightgreenhydrogen.org.uk/hydrogen-office-project/>
- [179] Invest in Fife. *The Hydrogen Office, Energy Park Fife*. [Brochure].
- [180] Carsten Reekers. *Energy storage in salt domes: IVG Cavern Storage Etzel*. IVG. [Presentation] Challenges in Energy supply - Energy Symposium, Eemshaven, June 3, 2013.
- [181] Isabelle Duffaure-Gallais. *Bâtiment tertiaire Un siège social autonome en énergie*. Le Moniteur. [Online] September 11, 2009. Available from: <https://www.lemoniteur.fr/article/batiment-tertiaire-un-siege-social-autonome-en-energie.509739>
- [182] Peter Focht. *Grüner Wasserstoff für Hanauer Industriepark*. Energie & Management GmbH. [Online] February 20, 2015. Available from: <https://www.energie-und-management.de/nachrichten/detail/gruener-wasserstoff-fuer-hanauer-industriepark-108526>
- [183] H2BZ Initiative Hessen. *Hessischer Elektrolyseur erfolgreich getestet*. [Online]. Available from: <https://www.h2bz-hessen.de/elektrolyseur>
- [184] Andrew Dicks. *Clean Energy Storage: Power-to-Gas*. Griffith University. [Presentation].
- [185] Alan Kneisz. *The Hydrogen Shift is Here, The Future of Power and Mobility*. Hydrogenics. [Presentation] ADB – Clean Energy Forum.
- [186] Agence Nationale de Recherche. *DEMETER project: Technical and economical feasibility of a renewable electricity storage loop on methane by the way of a reversible SOEC*. [Online]. Available from: <http://www.agence-nationale-recherche.fr/Project-ANR-11-SEED-0005>
- [187] K. Pütz and T. Norbech. *The way ahead for hydrogen in transport in Norway*. OECD, November 30, 2012.
- [188] Icelandic New Energy. *ECTOS Ecological City Transport System*. Second Newsletter.
- [189] European Commission. *The Hydrogen Fuelling Station, Ecological City Transport System. Demonstration, Evaluation and Research Project of Hydrogen Fuel Cell Bus Transportation System of The Future*. ECTOS – Deliverable 4. May 2003.
- [190] ACTA S.P.A. *Hydrogen generator demonstrated by Abengoa*. [Online]. Available from: <http://www.actaspa.com/hydrogen-generator-demonstrated-by-abengoa/>
- [191] EcoRally. *Carbon neutral liquid fuels - an investment pitch by Air Fuel Synthesis*. [Video] August 31, 2012. Available from: <https://www.youtube.com/watch?v=hafVXGoxb1s>
- [192] Valentine Willman. *Aberdeen Hydrogen Bus Project*. HyER. [Presentation] LowCVP Low Emission Bus Workshop, Glasgow, March 8, 2018.
- [193] HyER. *Hydrogen Bus Project*. [Online]. Available from: <http://hyer.eu/best-practices/hydrogen-bus-project/>
- [194] Bright Green Hydrogen. *Levenmouth Project*. [Online]. Available from:
- [195] <https://www.brightgreenhydrogen.org.uk/levenmouth-community-energy-project/>
- [196] Bright Green Hydrogen. *Levenmouth Community Energy Project*. [Presentation] APSE Scotland Fleet, Waste & Grounds Seminar 26-29th May 2015.
- [197] Iain Todd. *Levenmouth Community Energy Project: Project update*. [Presentation] All Energy Conference and Exhibition, Glasgow, 5 May 2016 Local Energy Economies event.

- [198] SYN FUEL Project website. [Online]. Available from: <http://www.synfuel.dk/about-the-project>
- [199] S. Kent Hoekman et al. *CO₂ recycling by reaction with renewably-generated hydrogen*. International Journal of Greenhouse Gas Control 4 (2010) 44–50.
- [200] Monika Landgraf. *Flexible Methane Production from Electricity and Bio-mass*. Karlsruhe Institute of Technology. [Online] December 17, 2014. Available from: http://www.kit.edu/kit/english/pi_2014_16120.php
- [201] Hitachi Zosen Inova. *Hitachi Zosen Corporation and Hitachi Zosen Inova to Build First Joint Power-To-Gas Plant*. [Online]. Available from: <http://www.hz-inova.com/cms/en/home?p=6276>
- [202] Aujchara Weerawong. *CO₂ Conversion to Methane Project*. PTT Exploration and Production PCL.
- [203] Harald Wiederschein. *Schadstofffrei in die Zukunft*. Focus Online. [Online] August 10, 2011. Available from: https://www.focus.de/wissen/technik/mobilitaet/antriebe/tid-23218/wunderkraftstoff-schadstofffrei-in-die-zukunft_aid_652598.html
- [204] Simone Pascuzzi et al. *Electrolyzer Performance Analysis of an Integrated Hydrogen Power System for Greenhouse Heating. A Case Study*. Sustainability, July 5, 2016.
- [205] Engie. *1 MWh with H₂ Microgrid in the Atacama Desert*. [Online]. Available from: <http://www.electropowersystems.com/portfolio-item/1mwh-with-h2-microgrid-in-the-atacama-desert-chile/>
- [206] HPEM2GAS project. *High Performance PEM Electrolyzer for Cost-effective Grid Balancing Applications*. [Brochure]. [Online]. Available from: http://hpem2gas.eu/download/project_flyer/UNIRESEARCH_HPEM2GAS_flyer_1718_web.pdf
- [207] Plataforma Tecnológica Española del Hidrógeno y las Pilas de Combustible Grupo de Análisis de Capacidades. *Estado de la Tecnología del Hidrógeno y las Pilas de Combustible en España*. 2005.
- [208] Naturgy. *Gas Natural Fenosa launches pilot project to produce renewable gas in Catalonia*. [Online] Madrid, May 31, 2018. Available from: <http://www.prensa.naturgy.com/en/gas-natural-fenosa-launches-pilot-project-to-produce-renewable-gas-in-catalonia/>
- [209] Jordi Guilera et al. *The COSIN project: synthetic natural gas production from biogas in a waste water treatment plant in Barcelona*. [Online] International Conference on Renewable Energy, April 25-27, 2018. Available from: <http://programme.exordo.com/icren2018/delegates/presentation/38/>
- [210] BALANCE Project website. [Online]. Available from: <https://www.balance-project.org/projects/>
- [211] Power to Flex project website. [Online]. Available from: <https://www.powertoflex.eu/en/>
- [212] FCH JU. *Project RESelyser, Hydrogen from RES: pressurised alkaline electrolyser with high efficiency and wide operating range*. [Online]. Available from: <https://www.fch.europa.eu/project/hydrogen-res-pressurised-alkaline-electrolyser-high-efficiency-and-wide-operating-range>
- [213] Gas Natural Fenosa. *RENOVAGAS Project: Power to Methane*. [Presentation] Western Region Workshop – 28 & 29 Sept 2017 – Lisbon, Portugal.
- [214] Loïc Mangin. *L'hydrogène, accélérateur de la transition énergétique*. ENGIE. March 2018.
- [215] Energy, Oil & Gas. *STORAG ETZEL GmbH*. [Online] July 2016. Available from: <http://www.energy-oil-gas.com/2016/07/15/storag-etz-el-gmbh/>
- [216] Abdol S. Soofi and Mehdi Goodarzi. *The Development of Science and Technology in Iran: Policies and Learning Frameworks*. [Online] E-book, December 7, 2016. Available from: https://books.google.fr/books?id=O5-wDQAAQBAJ&pg=PA192&lpg=PA192&dq=taleghan+hydrogen+project+start+date&source=bl&ots=FiQ2Luu9nS&sig=g80ec_e5-B51sQal8qf0PhmzNS4&hl=fr&sa=X&ved=2ahUKewivwLrbg5LdAhWlxlUKHX_fAVYQ6AEwAnoECAgQAAQ#v=onepage&q=taleghan%20hydrogen%20project%20start%20date&f=false

- [217] Sebastian Becker. *Power-to-Liquids as a new Energy Option, Potentials and Difficulties/Uncertainties*. Sunfire GmbH. [Presentation]. [Online] January 11, 2013. Available from: https://www.umweltbundesamt.de/sites/default/files/medien/377/dokumente/19_session_i_5_becker.pdf
- [218] Aravind PV, Vikrant Venkataraman. *BALANCE Deliverable D5.1, Identification of potentially attractive process chains for reversible solid oxide cell rSOC (systems): power to commodity and vice versa for grid stabilisation*. TU Delft. May 21, 2018.
- [219] Salman, Sartory and Klell. *Wind2Hydrogen – Umwandlung von erneuerbarem Strom in Wasserstoff zur Speicherung und zum Transport im Erdgasnetz*. HyCentA. [Presentation] Symposium Energieinnovation, February 12, 2016.
- [220] Natural Resources Canada. *Glencore RAGLAN Mine Renewable Electricity Smart-Grid Pilot Demonstration*. [Online]. Available from: <https://www.nrcan.gc.ca/energy/funding/current-funding-programs/eii/16662>
- [221] VTT. *Demonstration of bio-CO2 products with novel research platform*. bioeconomy+. [Online]. Available from: <https://www.vtt.fi/sites/bioeconomyplus/en/contacts>
- [222] Demo4Grid project website. [Online]. Available from: <https://www.demo4grid.eu/project/>
- [223] FCH JU. *Demo4Grid Demonstration of a 4 MW Large Scale Pressure Alkaline Electrolysis for Grid Balancing Services*. [Presentation]. [Online]. Available from: http://elyntegration.eu/wp-content/uploads/DEMO4GRID_IHT_Session_3.pdf
- [224] W. Stahl, K. Voss, and A. Goetzberger. *The self-sufficient solar house in Freiburg*. Solar Energy Vol. 52, No. 1, pp. 111-125, 1994.
- [225] LNG World News. *Gasunie, Greenpeace Energy Choose Suderburg as Windgas Location, Germany*. [Online] September 28, 2012. Available from: <https://www.lngworldnews.com/gasunie-greenpeace-energy-choose-suderburg-as-windgas-location-germany/>
- [226] Greenpeace Energy. *Neuer schwung für die energiewende: windgas made in Suderburg*. [Online] September 19, 2012. Available from: <https://www.greenpeace-energy.de/presse/artikel/neuer-schwung-fuer-die-energiewende-windgas-made-in-suderburg.html>
- [227] Nick Harmsen. *Hydrogen to be injected into Adelaide's gas grid in 'power-to-gas' trial*. ABC News. [Online] August 7, 2017. Available from: <http://www.abc.net.au/news/2017-08-08/trial-to-inject-hydrogen-into-gas-lines/8782956>
- [228] *El Hidrógeno y las pilas de combustible, el recorrido de la energía*. Junta de Castilla y Leon. 2007.
- [229] C. Philibert, Renewable energy for industry, IEA, 2017.
- [230] Dolci F, et al. Incentives and legal barriers for Power-to-Hydrogen pathways: an international snapshot. Int J Hydrogen Energy May 2019;44(23):11394e401.
- [231] M. Robinius et al., *Techno-economic potential of Power-to-Hydrogen pathways: An international literature review*, Int J Hydrogen Energy, under review.
- [232] Ministère de la Transition Ecologique et Solidaire, Plan de déploiement de l'hydrogène pour la transition énergétique, 2018.
- [233] NREL, H2 at scale: Deeply Decarbonizing Our Energy System, 2016
- [234] Hydrogen Council, How hydrogen empowers the energy transition, January 2017.
- [235] Hydrogen Council, Hydrogen scaling up, A sustainable pathway for the global energy transition, Nov. 2017
- [236] O. Tlili et al., "Rethinking the way to decarbonize the energy system: prospective study of hydrogen market attractiveness", presented at the 40th IAEE International Conference, Singapore, Malaysia, June 18-21, 2017.
- [237] A. De Vita et al., Sectoral integration- long-term perspective in the EU Energy System, Final report of the ASSET project, 2018.

CHAPTER III

Subtask 3B: Review of the existing legal context and policy measures

Authors: Francesco Dolci¹, Denis Thomas², Samantha Hilliard³, Carlos Fúnez Guerra⁴, Ragnhild Hancke⁵, Hiroshi Ito⁶, Mathilde Jegoux⁷, Gijs Kreeft⁸, Jonathan Leaver⁹, Marcus Newborough¹⁰, Joris Proost¹¹, Martin Robinius¹², Eveline Weidner¹, Darja Markova¹³, Ezequiel Serwatka¹⁴, Ricardo Ariel Perez¹⁴, Christine Mansilla^{15*}, Olfa Tlili¹⁵, Paul Lucchese¹⁵

Affiliations:

- (1) European Commission, Joint Research Centre (JRC), Petten, Netherlands;
- (2) Hydrogenics;
- (3) Clean Horizon, France;
- (4) Centro Nacional del Hidrógeno, Spain;
- (5) IFE, Norway;
- (6) AIST (Advanced Industrial Science and Technology), Japan;
- (7) Engie, France;
- (8) Groningen University, the Netherlands;
- (9) Unitec Institute of Technology, New Zealand;
- (10) ITM Power, UK;
- (11) Université Catholique de Louvain, Division of Materials and Process Engineering, Belgium;
- (12) Forschungszentrum Jülich GmbH, Institute of Electrochemical Process Engineering (IEK-3), Germany;
- (13) Energie Institut an der Johannes Kepler Universität Linz, Austria
- (14) Hychico, Argentina
- (15) CEA, Université Paris Saclay, France;

**Corresponding author: christine.mansilla@cea.fr CEA Saclay, DAS I-tésé, Bat. 524, 91191 Gif-sur-Yvette, France*

As shown in the last section, the demonstration projects allow learning what challenges PtX pathways are facing. These challenges are not only cost-related. They also include an inadequate regulatory framework often presenting a barrier to hydrogen deployment projects. The next chapter addresses the regulatory bottlenecks but also the required incentives concerning PtX developments.

Key messages

- Low-carbon H₂ can play a role in the electric, gas, transport, and industry sectors.
- This chapter provides a snapshot of the legal context for power-to-H₂ in 12 countries.
- The most acknowledged pathway, from a legal standpoint, is mobility applications.
- Only few countries are implementing legal frameworks for diverse H₂ applications.

Abstract

Rendering the energy system more sustainable can only be achieved through a combination of low-carbon energy production, energy efficiency, and coupling of energy sectors. In this context, Power-to-Hydrogen concepts for managing supply and demand, providing seasonal storage, and being the linking element between different sectors (electricity generation, gas grids, transport, and industry), has attracted significant interest during the last decade. However, the deployment of technology is subject to legal barriers, which may differ from one region to another. On the contrary, there may be incentives to facilitate market introduction of a new technology.

In this paper, an international network of experts under the umbrella of Task 38 of the International Energy Agency's Hydrogen Technology Collaboration Programme assesses the legal framework in ten countries regarding power-to-hydrogen applications. The most frequently considered pathway, from a legal standpoint, is using hydrogen for mobility applications. Only a few countries are implementing legal frameworks for diverse hydrogen applications.

Keywords

- Power-to-Hydrogen
- Hydrogen-to-X
- Power-to-Gas
- Incentives
- Legal
- Sector Coupling

Introduction

In the last couple of years, several countries worldwide have issued hydrogen visions documents, with the aim of exploring the decarbonisation possibilities offered by hydrogen technologies and hydrogen deployment across several sectors.

These visions are integrated in the framework of a larger scope on climate goals.

In Europe for instance, the climate goals are threefold [1]: i) At least 20% (2020), 55% (2030) and 80% (2050) cuts in greenhouse gas emissions should be achieved compared to 1990 levels; ii) At least 20% (2020) and 27% (2030) of total energy consumption from renewable energy should be reached (the new Renewable Energy Directive set a 32% target for renewable energy by 2030), and iii) at least 20% (2020) and 27% (2030) increase in energy efficiency attained (the new Renewable Energy Efficiency Directive set a 32.5% target for energy savings by 2030). These objectives have been updated and brought even further (achievement of carbon neutrality by 2050) with the issuing of the European Green Deal [2].

Such a transformation is demanding, and all possible means need to be leveraged, i.e. a combination of low-carbon energy, energy efficiency, and the coupling of energy sectors [3]. The application of Power-to-Hydrogen concepts for managing demand, providing seasonal storage, and linking element between different sectors (electricity generation, gas grids, transport and industry), has attracted significant interest during the last decade.

In the last years, an ever-increasing number of demo projects associated with power-to-hydrogen applications are being carried out through the globe and several Task 38 members reporting initiatives in their home countries. These offer opportunities for gaining field experience and gaining important insight in how legislation can impact the deployment of hydrogen technologies.

In this chapter, an international network of experts under the umbrella of Task 38 of the International Energy Agency's Hydrogen Technology Collaboration Programme [4] carries out an assessment of the legal framework related to Power-to-Hydrogen pathways in twelve countries: Argentina, Austria, Belgium, France, Germany, Italy, Japan, New Zealand, Norway, Spain, The Netherlands, and the United Kingdom. Only national legislation is considered, as the review does not examine at a regional scale.

The following section focuses on the incentives. When none are mentioned, it means that none currently exist. Section 3 then provides an overview of the legal barriers.

Incentives

Promoting low-carbon hydrogen production (PtH)

Power-to-Hydrogen pathways can contribute to the transition towards a low-carbon energy system, provided of course that hydrogen is produced in a sustainable way. Indeed, today 96% of hydrogen is produced from fossil fuels [5]. To ensure the low-carbon origin of hydrogen, some renewable or green hydrogen certification mechanism should be defined and established. In Europe, there are some on-going initiatives regarding certification. The project CERTIFHY aims at establishing the first Green Hydrogen Guarantee of Origins (GOs) that will be available for sale EU-wide [6]. The work distinguishes between renewable and low-carbon origins. Under the new EU Renewable Energy Directive, the role of renewable hydrogen is now explicitly acknowledged [7]. A standardisation effort is also ongoing. At the European level, the European Committee for Electrotechnical Standardization (of the European Committee for Standardization, CEN – CENELEC [8]) is developing a standard on Guarantee of Origin for production of hydrogen.

Since 2006, Argentina has put in place incentive for promoting the production, use and applications of hydrogen through the National Law N° 26.123 [9].

In Austria, a regulation providing for the certification and labelling of gas has been adopted and is in force since January 2020 (so-called Gaskennzeichnungsverordnung) [10].

The situation varies for supporting policies for hydrogen production from electrolysis (PtH). In Austria, according to § 111 (3) EIWOG 2010, facilities converting electricity into hydrogen or synthetic natural gas, which are commissioned for the first time after 7 August 2013 until the end of 2020, do not have to pay any of the system utilisation charges and charges for system losses prescribed for the purchase of electrical energy until the end of 2020 [11].

In Norway hydrogen produced through electrolysis is exempt from electricity consumption taxes (not from grid tariffs though) [12]. Specific subsidies are available in the Netherlands as the Ministry of Economic Affairs established a subsidy programme for energy projects, including a specific subsidy for hydrogen-related projects (not limited to production). The maximum allowable funding is 750,000 € per project [13].

Incentives towards the use of hydrogen in the transport sector

Regarding the downstream uses of hydrogen production, the incentives vary drastically from one pathway to the other. The most favourable pathway (and the most incentivized) is the use of hydrogen in fuel cell vehicles (H₂F-H₂).

- Incentivizing the infrastructure deployment

First, incentives to foster the deployment of a hydrogen infrastructure (to address the well-known chicken and egg problem) are deployed by several nations.

In Italy, public incentives (EU and national) are expected to reach 47 million € in 2020 and 419 million € for 2021-2025, 40% of them being national funds [14]. In Germany, the eMobility funding programme includes a 300 million € for infrastructure [15]. The Alternative Fuel Infrastructure Directive (AFID) EU 2014/94 implementation involves the construction of 400 hydrogen refuelling stations by 2023 in Germany [15]. In Japan, half of construction costs of the HRS are subsidized regardless of the origin of the hydrogen [16]. In Norway, a national investment support program for the establishment of hydrogen refuelling stations was launched in spring 2017, where up to 40 % of project costs can be covered. Technical requirements of this programme demand a minimum capacity of 200 kg H₂/day and a minimum of two fuelling nozzles, in which one should deliver at 700 bar [17]. In the Netherlands, subsidies for the deployment of hydrogen refuelling stations are provided for under the Hydrogen subsidy programme of the Ministry of Economic affairs [18]. Finally, in Belgium, excise tax is not paid on the sale of hydrogen as a transport fuel. Another indirect European incentive is the possibility to account for renewable liquids or gaseous fuels of non-biological origin used in the transport sector as contributing to the required targets as defined in European legislation (e.g.: RED II).

- Incentivizing the vehicle purchase

Still, regarding the H₂F-H₂ pathway, there are a number of incentives regarding fuel cell electric vehicles.

In some cases, these incentives are binding regulations. In the Netherlands, from 2035 onwards, all new passenger vehicles must be able to drive with a carbon neutral footprint [19]. Most often, the incentives consist of subsidies for vehicle purchase. Several grants are possible for electric or fuel cell electric cars. The order of magnitude is usually several thousand euros.

In Austria, pure electric vehicles are exempted from the standard consumption tax (so-called

Normverbrauchsabgabe) and are exempt from engine-related insurance tax.

Subsidies for private battery electric and fuel cell electric vehicles amount to 3,000 € per vehicle. "Electric cars and light electric utility vehicles" together with "Electric Minibuses" and "Electric Light Vehicles" used by for companies, local authorities, associations also benefit of subsidies depending on their class and ranging from 1,000 to 20,000 € per vehicle. Electric cars are input tax deductible (vorsteuerabzugsfähig) if they are purchased as company cars. Electric drive vehicles are excluded from the IG-L (Immissionschutzgesetz Luft) speed limit. In some communities, EV are already allowed to park for free - in a next step, bus lanes for EV will be opened and free parking for electric cars will be promoted [20].

In Belgium, a 4,000 euro grant is available in Flanders for all electric cars, but it is not applicable for companies/leasing [21]. In Germany, for electric cars (including fuel cell ones), there is a grant of 4,000 €. For hybrid cars, it amounts to 3,000 €. Rewards are only for cars with a list price of maximum 60,000 € (base model). The promotion lasts for a maximum total of 400,000 cars. The federal government contributes a total of 600 million €, and this cost is shared equally between the federal government and the automakers. Overall, the funding reaches 1.2 billion €. This promotion will end in 2020 [22]. In Japan, the national subsidy for fuel cell hydrogen electric vehicles is of 2.02 million JPY (i.e. 15,000 €/vehicle) [23]. It ranges from 0.1 to 0.4 million JPY for other kinds of electric cars. In France, 27% of the price of the vehicle (taxes and batteries included) is subsidised, not exceeding a maximum of 6,000 €. This is granted for the acquisition of a new vehicle which emits less than 20gCO₂/km (except for hybrid vehicle which use diesel). For vehicles emitting between 21 and 60 g CO₂/km, the premium is 1,000 €. There is also a diesel scrappage scheme: switching a 11-year-old -or older- diesel car for a new electric car grants an extra 4,000 € (or 2,500 € in case it is a plug-in hybrid electric vehicle). The "L" category (Quadricycles, Motorbikes, Scooters...) has a 250 € per kWh purchase subsidy (lead battery vehicles excluded), with a limit of 1,000 € or 27% of purchase price [24, 25]. In Spain, electric vehicles can benefit from incentives ranging between 1,100 and 15,000 €; it amounts to 5,500 € for fuel cell electric vehicles [26]. In the Netherlands, for lease/company cars, the fiscal costs for the private use of zero-emission lease cars, including fuel cell electric vehicles, are limited to 4%. Petrol cars pay 22% [27, 28]. In the UK, there is a government grant of £4,500 (approximately 5,000 €) for buyers of fuel cell electric vehicles [29].

Additionally, several countries grant an exemption (partial or total) of registration tax to electric and fuel cell electric vehicles. In Belgium, electric and plug-in hybrid vehicles are exempt from registration tax (in Flanders only) [21]. In France, there are road tax exemption and reduction of matriculation certificate fees (French "carte grise"). The reduction for a *clean engine* vehicle depends on the region [30]. In Spain and Norway, there is purchase tax exemption [31, 32]. In the Netherlands, zero-emission cars are exempt from paying the registration tax. For the other kinds of cars, the system is progressive, with five levels of CO₂ emissions which pay different amounts of registration tax. Plug-in hybrid cars go to level 1 (1-79 gCO₂/km) and pay 6 € per gram. For level 2 (80-106 gCO₂/km), the tariff is 69 € per gram CO₂. The final level is 476 € per gram for cars emitting 174 gCO₂/km or over [28].

There are also ownership tax exemptions (partial or total) in several countries.

In Belgium, electric vehicles pay the lowest rate of tax under the annual circulation tax in all three regions. (74 € instead of 1,900€) [21]. In Italy, electric vehicles are exempted from the annual circulation tax (ownership tax) for a period of five years from the date of their first registration. After this five-year period, in many regions, they benefit from a 75% reduction of the tax rate applied to equivalent petrol vehicles [33]. In Germany, the exemption is for the first ten years for cars registered until Dec 31, 2015, then five years afterwards until Dec 31, 2020 [22]. In Norway and Spain, tax reductions also exist. In the Netherlands, exemption from motor vehicle taxes and road tax is granted for fuel cell electric vehicles [34]. Finally, in New Zealand, there is a 385€ road user charge exemption, and a 44€ reduction in compulsory personal injury insurance.

Incentives towards the use of low-carbon hydrogen in the industry and for electricity production

There are few supporting policies for the use of green hydrogen in industry (HtI).

In France and the Netherlands replacement of fossil-fuel derived hydrogen is encouraged by tax exemptions. In France, the use of renewable hydrogen in industry has an impact on avoiding the carbon tax ("Contribution Climat-Énergie") which was 30.5€/tCO₂ in 2017, and should reach a level of 100€/tCO₂ by 2030 [35]. In the Netherlands, investments which result in the replacement of fossil fuels by hydrogen are deductible from the profit before being taxed up to 41.5% [36].

In Austria, hydrogen cannot take advantage of specific feed-in tariffs dedicated to green electricity obtained from biogas, since synthetic natural gas and hydrogen from power-to-gas plants, according to Austrian legislation do not fall into the definition of biogas. Thus, there are no supporting policies for re-electrification of hydrogen [37].

Argentina does not yet have dedicated legislation, but the project Hychico is using renewable hydrogen production from wind turbines to power a genset where it is combusted together with natural gas [38].

Incentives towards blending with natural gas

The case for Hydrogen-to-Gas pathways is peculiar (HtG). Bio-methane feed-in tariffs do exist in many countries. Bio-methane injection (in the natural gas grid) feed-in tariffs are being discussed in Flanders and Wallonia [39].

In Austria, according to the exemptions for production of hydrogen previously mentioned, it can be surmised that the electricity input necessary for the production and feed-in of hydrogen or synthetic natural gas is exempt from the electricity levy (so-called "Elektrizitätsabgabe" and that these applications are exempted from the obligation to pay further charges such as the renewables contribution, flat-rate renewables charge, and the CHP flat-rate. Hydrogen based on renewable energy (and synthetic gas produced from renewable hydrogen) is tax-exempt with respect to the payment of the natural gas levy (the so-called "Erdgasabgabe") [40].

In Germany, bio-methane utilisation is eligible for feed-in tariffs only when being used for CHP [41]. In France, bio-methane feed-in tariffs were fixed in 2016 for a period of 15 years [42]. The producer will benefit from a feed-in-tariff between 46 and 139 €/MWh. In the Netherlands, for the production of energy products from biomass, operators can request a subsidy. The amount of subsidy is awarded for every kWh injected into the gas grid and covers the difference between the price of bio-methane and natural gas, with a maximum amount of 6 million € per project and a period of 12 years [43, 44]. In the Netherlands, the bio-methane feed-in tariffs is 3.6 €/kWh for first 40 GWh injected, falling to 2.1 €/kWh for next 40 GWh, and to 1.6 €/kWh for any remainder from sites injecting >80 GWh [45].

However, some questions arise: is synthetic methane produced through the methanation pathway (HtG-M) eligible for similar feed-in tariffs? And what about direct blending of hydrogen (HtG-H₂) and tariffs that respect the blend concentration? Today, none of these schemes recognize synthetic gas or hydrogen as a green gas eligible for a green gas feed-in tariff. What is more, concerning the latter, there is the additional issue of the maximum concentration of hydrogen in the hydrogen-natural gas blend. This is addressed in the following section on legal barriers.

Legal barriers

Regarding hydrogen production

For the production of hydrogen, regulations (especially regarding safety) are being implemented. In Europe the reference European directives are the "Seveso" and "ATEX" ones, which can be implemented differently in each Member State. In France, for instance, special permitting is required for hydrogen production and storage [46, 47]. Hydrogen production sites "making industrial quantities" are subject to ICPE authorisation (ICPE, Installation Classée pour la Protection de l'Environnement in French, facilities classified for environmental protection), which is a binding regime. This case is under negotiation for a less constraining administrative regime for hydrogen obtained via water electrolysis. Hydrogen sites

storing strictly less than 100 kg of hydrogen are not subject to administrative constraints. An ICPE declaration needs to be made if the stored quantity ranges from 100 kg to 1000 kg. An ICPE authorisation is compulsory for quantities beyond 1000 kg.

In Spain, regardless of the amount of hydrogen produced, it is necessary to process and obtain the environmental impact assessment [48] and integrated environmental authorization [49]. The Spanish legislation does not differentiate the sources of hydrogen production: they must comply with all the same environmental requirements.

These permitting regimes in France, Spain and other EU countries is to a large extent prescribed under the EU Industrial Emissions Directive under which Power-to-Hydrogen is considered an activity for the ‘production of inorganic chemicals’ [50]. The permitting regime for such installations does not differentiate between different hydrogen production pathways such as Power-to-Hydrogen and methane steam reforming.

Regarding hydrogen blending with natural gas

Regarding the direct injection of hydrogen in the natural gas grid, the authorized concentrations vary significantly from country to country because historically, when the existing regulations were introduced, there was no consideration of the possibility of gas grids conveying hydrogen admixtures (see Table 2). In Germany for example, there are no national legislative restrictions regarding the hydrogen content in natural gas. The limitations vary from 10 vol.-% as an admixture to below 2 vol.-% if a CNG filling stations is connected, and if no calibrated hydrogen measurement system is installed, the hydrogen content shall not exceed 0.2 vol.-% [51]. A similar conflict exists in Austria, where the permitted hydrogen concentration in the grid is 4 vol.%, but it is restricted to 2 vol.% for natural gas powered vehicles [40].

Argentina has no regulation that explicitly mandates a maximum hydrogen percentage. The gas HHV is the only parameter which has to be monitored [52].

When assuming perfect gases, molar and volume percentages are equivalent. As a result, the values taken from the regulatory frameworks can be ranged to catch the rate diversity (see Figure 17). This is a major bottleneck to develop this pathway, since even when allowed, the maximum concentration of hydrogen is low. Projects like GRHYD [53] and HyDeploy [54], which have local exemptions to inject up to 20% hydrogen, are pushing the boundary and may lead to new regulations and greater harmonisation across Europe.

Table 2. Allowed hydrogen concentration in the gas grid, according to the countries

	Austria	Belgium	Italy	Germany	France	Japan	Spain	Netherlands	UK
	[40]	[55]	[56]	[57]	[58]	[16]	[59]	[60]	[61]
Maximum H₂ concentration allowed in the gas grid	< 4% vol	< 0.1% mol	<2-3 % vol	<10% mol				0.02% mol	
	by 2030, the hydrogen tolerance in the gas network should be 10%.	(injection up to 2% vol could be considered)	(0.5% vol for bio-methane)	(<2% mol-for CNG tanks)	6% mol	0% mol	5% mol	(There are plans to raise this to 0.5% mol)	0.1% mol

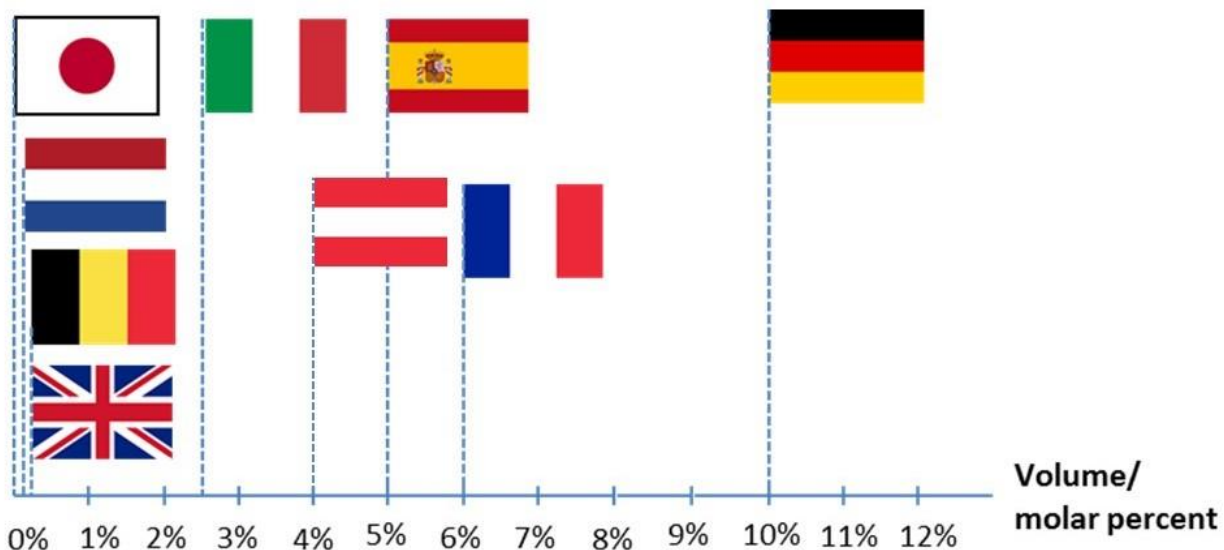

Figure 17. Hydrogen blending rates range

Regarding hydrogen use for the transport sector

There are also legal barriers related to the use of hydrogen in fuel cell vehicles.

Accuracy in hydrogen dispensing is a significant issue in several European countries, as well as homogeneously standardised connectors.

In Belgium, measurement accuracy in fuel distribution must meet specific accuracy criteria (metrology, based mainly on liquid fuels). Current technologies do not meet these criteria and therefore intermediate regulations need to be adapted to provide for payment terminals accepting bank card payments. In Germany, the allowable dispensing tolerance of 1% to 1.5% is prescribed. Unfortunately, it is not possible to reach the required accuracy, therefore a derogation has been requested for the existing hydrogen refuelling stations to allow for higher tolerances [62]. In France, a decree is in preparation, for stations with storage capacities lower than 1 tonne H₂ (declaration with periodic control). Hydrogen vehicle refuelling points, or renewed refuelling points, across the EU are currently unable to meet the AFID [63] requirement concerning the deployment of ISO 17268 compliant nozzles, because such technology is not yet available commercially. The transposition of AFID Article 5, clause 2, has been implemented inconsistently across the EU with some countries requiring the use of ISO 17268 compliant nozzles (e.g. Sweden, Spain, Netherlands, UK) while others do not (e.g. France, Denmark and Germany).

Additionally, permitting procedures are required for hydrogen refuelling stations, with regard to safety considerations.

General outlook

Considering the legal barriers and incentives that were identified in this article, an attempt to characterise the legal framework for each pathway and country is carried out in Table 3.

It is worth noting that the European HyLAW project [64] is investigating the specific details of the existing legal barriers pushing back against the development of hydrogen systems in Europe.

Table 3. Legal framework according to the pathways

Country	AR	AT	BE	FR	DE	IT	JP	NZ	NO	ES	NL	UK
PtH		Favourable		Difficult					Favourable		Favourable	
HtP		Favourable									Favourable	
HtF		Favourable									Favourable	
HtG		Favourable									Favourable	
HtI												
HtCh												
HtQ												

PtH	Power-to-Hydrogen
HtP	Hydrogen-to-Power
HtG-H2	Hydrogen-to-Gas (feed-in H2)
HtG-M	Hydrogen-to-Gas (feed-in of synthetic methane)
HtF-H2	Hydrogen-to-Fuel (Hydrogen)
HtF-S	Hydrogen-to-Fuel (liquid synfuels)
HtF-G	Hydrogen-to-Fuel (gaseous synfuels)
HtI	Hydrogen-to-Industry
HtQ	Hydrogen-to-Heat
HtCh	Hydrogen-to-Chemicals

Favourable context	■
Somehow favourable	■
Somehow difficult	■
Difficult context	■
No information	

From this table, it clearly appears that the most acknowledged pathway, from a legal standpoint, is the use of hydrogen as fuel for fuel-cell vehicles since it benefits from general incentives for electric or low-emission vehicles. Hydrogen blending in the natural gas grids is trickier under the current regulation. Specific regulations seem to be lacking for several pathways. Some frameworks are in place, such as the one for bio-methane, but at this time it remains unclear whether this will be an opportunity for PtH pathways in the future. Incentives begin appearing for the industrial sector, which is recently gaining momentum [65].

Compared to other countries, the Netherlands seem to be implementing a global legal framework, encompassing the variety of hydrogen applications as shown in recent works and scenarios [66-70]. France seems to be on the same pathway, but industry uses do not appear in the agenda of most examined countries.

Conclusion and policy recommendations

‘Low-carbon’ hydrogen (i.e. that produced through low-carbon pathways, such as water electrolysis powered with low-carbon electricity) can be used by different energy-consuming services. It has a potential role to play in the electric, gas, transport, and industrial sectors. This paper presents a review of the incentives and legal barriers in twelve countries, with regard to Power-to-Hydrogen and Hydrogen-to-X pathways, as communicated by Task 38 members.

The main application specific to hydrogen for which countries have already started to develop explicit regulations is the use of hydrogen in fuel cell vehicles. A number of incentives were implemented, either

for low-emission vehicles in general or specifically for hydrogen vehicles. For the pathways involving the natural gas grid, there are still barriers. Allowed injection limits for hydrogen are low, and feed-in tariffs are only implemented for bio-methane. On the other hand, incentives are beginning to appear for the industrial sector.

However, the specificity of hydrogen being a versatile energy carrier seems to be often disregarded. Only few countries are implementing legal frameworks facilitating diverse hydrogen applications. Also, the potential benefits of hydrogen production via water electrolysis in contributing to the electric system stability and greater integration of variable renewables seem neglected as well. Power-to-Hydrogen production via electrolysis is rarely promoted directly. Among the countries covered, only Norway has implemented an electricity tax exemption for hydrogen production.

From the review that was carried out, some policy recommendations can be identified:

- Promote hydrogen use with a holistic approach, by encompassing all the possible pathways (PtX):
 - o Develop incentives in the transport sector beyond the sole light passenger duty vehicles (i.e. by including trucks, trains, maritime use), and incentivize the infrastructure development jointly with the vehicle purchase;
 - o Remove the legal barriers for the blending of hydrogen with natural gas by harmonizing the blending concentrations, and set thresholds based on physical constraints [71]; acknowledge the actual greenhouse gas mitigation for gas applications by also accounting the contribution of methane leakages during processing and transport of natural gas (and implement the relevant incentives/penalties accordingly); implement support schemes as it is done for bio-methane injection;
 - o Promote the use of low-carbon hydrogen in industry by implementing adequate certificates and/or penalties; ensure a "level playing field" for products obtained with low-carbon hydrogen;
- Promote the production of low-carbon hydrogen:
 - o Implement adequate regulations on polluting activities (e.g. carbon taxation);
 - o Acknowledge the contribution of hydrogen systems to the development of renewables (develop certificates, tax exemption for the power consumed by electrolyzers (especially when hydrogen is meant to produce power, grid tariff exemption could also be considered); allow participation to ancillary services and capacity mechanisms).

Even if favourable economic conditions are met, Power-to-Hydrogen pathways will only develop provided that appropriate regulations make it possible. The attention of stakeholders must be raised on this topic. At present there is a lack of regulations or penalties being applied to conventional polluting methods of hydrogen production to make them more expensive and ease the transition to low-carbon hydrogen.

Investigating the incentives and legal barriers for hydrogen system deployment is an on-going task. This paper provides a short, high-level, snapshot. Future research will develop the current analysis to cover a number of additional countries.

Acknowledgements

The present work was carried out within the framework of Task 38 of the Hydrogen Technology Collaboration Programme of the International Energy Agency. The task is coordinated by the Institute for techno-economics of energy systems (I-tésé) of the CEA, supported by the ADEME. Special thanks to Rob Dickinson for his precious help with the references of this chapter.

REFERENCES

- [1] *EU climate action*, 2018.
- [2] E. Commission. "EU climate action & Green Deal," https://ec.europa.eu/clima/policies/eu-climate-action_fr.
- [3] M. Robinius, A. Otto, P. Heuser *et al.*, "Linking the Power and Transport Sectors-Part 1: The Principle of Sector Coupling," *Energies*, vol. 10, no. 7, pp. 956, Jul, 2017.
- [4] P. Lucchese, and *et al.*, "Power-to-Hydrogen and Hydrogen-to-X: Midterm appraisal of the IEA HIA Task 38 accomplishments."
- [5] International Renewable Energy Agency. "Hydrogen from renewable power: Technology outlook for the energy transition," <https://www.irena.org/publications/2018/Sep/Hydrogen-from-renewable-power>.
- [6] W. Vanhoudt, F. Barth, J. C. Lanoix *et al.*, "Power -to-gas short term and long term opportunities to leverage synergies between the electricity and transports sectors through power-to-hydrogen," *LBST; HINICIO*, 2016.
- [7] Council of the European Union. "Interinstitutional File:2016/0380 (COD)," <https://data.consilium.europa.eu/doc/document/ST-15886-2017-INIT/en/pdf>.
- [8] European Commission. "CEN - CENELEC Sector Forum Energy Management/Working Group Hydrogen: Final Report," <https://ec.europa.eu/jrc/en/publication/cen-cenelec-sector-forum-energy-managementworking-group-hydrogen-final-report>.
- [9] N. C. P. Database, "Law 26.123 (2006) Promotion of Hydrogen Energy Argentina 2006."
- [10] E-Control. "Vorblatt, Gaskennzeichnungsverordnung - G-KenV," https://www.e-control.at/documents/1785851/0/Erl%C3%A4uterungen+Gaskennzeichnungs-VO+26082019_final+nach+Regulierungsbeirat+%281%29.pdf/cf934481-50ee-5587-016b-4726394ffe40?t=1568798614178.
- [11] H.Hauenschild, I.Micheler, K.Oberndorfer *et al.*, "EIWOG Kommentar," 2013.
- [12] LOVDATA. "Forskrift om særavgifter Kapittel 3. Særskilte bestemmelser om de enkelte avgiftene (Regulations on special fees Chapter 3. Special provisions on the individual fees)," https://lovdata.no/dokument/SF/forskrift/2001-12-11-1451#KAPITTEL_3.
- [13] R. v. Nederland, "Subsidie Waterstof pilotregeling," 2018.
- [14] Ministero dello Sviluppo Economico. "Strategia Energetica Nazionale 2017 Audizione Parlamentare," 2020; https://www.sviluppoeconomico.gov.it/images/stories/documenti/SEN_Audizione_Parlamentare_1marzo_2017.pdf.
- [15] EU Fuelcells and Hydrogen Joint Undertaking (FCH JU). "4th International Workshop on Hydrogen Infrastructure and Transportation," 2020.
- [16] Hiroshi Ito, 2018.
- [17] ENOVA. "Hydrogeninfrastruktur," <https://www.enova.no/bedrift/landtransport/hydrogeninfrastruktur/>.
- [18] Government of The Netherlands. "Regeling nationale EZK- en LNV-subsidies," <https://wetten.overheid.nl/BWBR0035474/2020-09-02>.
- [19] De Sociaal-Economische Raad (SER). "Het Energieakkoord," <https://www.ser.nl/nl/thema/energie-en-duurzaamheid/energieakkoord>.

- [20] L. I. S. o. t. R. o. A. (RIS), "Normverbrauchsabgabegesetz - NoVAG 199."
- [21] European Alternative Fuels Observatory. "Alternative fuels data for Belgium," <https://www.eafo.eu/content/belgium>.
- [22] European Alternative Fuels Observatory. "Alternative fuels data for Germany," <https://www.eafo.eu/content/germany>.
- [23] NeV. "About Japan's Next Generation Vehicle Promotion Cente," <http://www.cev-pc.or.jp/english/>.
- [24] European Alternative Fuels Observatory. "Alternative fuels data for France," <https://www.eafo.eu/content/france>.
- [25] République Française, "Bonus écologique pour un véhicule électrique ou hybride (voiture, vélo...) [Ecological bonus for an electric or hybrid vehicle (car, bicycle, etc.)]," 2020.
- [26] Agencia Estatal Boletín Oficial del Estado del Spain. "Boletín Oficial del Estado, Num. 149, Viernes 23 de junio de 2017, Sec. I. Pág. 51631, Real Decreto 617/2017, de 16 de junio por el que se regula la concesión directa de ayudas para la adquisición de vehículos de energías alternativas [Official State Gazette, Num. 149, Friday June 23, 2017, Sec. I. Page 51631, Royal Decree 617/2017, of June 16, which regulates the direct granting of aid for the acquisition of vehicles of alternative energies]," <https://www.boe.es/boe/dias/2017/06/23/pdfs/BOE-A-2017-7165.pdf>.
- [27] Minister van Financiën of The Netherlands. "De voorzitter van de Tweede Kamer der Staten-Generaal Betreft Autobrief II (The chairman of the House of Representatives of the States General Regarding Car Letter II)," <https://www.rijksoverheid.nl/binaries/rijksoverheid/documenten/kamerstukken/2015/06/19/autobrief-ii/de-autobrief-ii.pdf>.
- [28] European Alternative Fuels Observatory. "Alternative fuels data for The Netherlands," <https://www.eafo.eu/content/netherlands>.
- [29] UK Government. "Low-emission vehicles eligible for a plug-in grant," <https://www.gov.uk/plug-in-car-van-grants>.
- [30] République Française. "Coût de la carte grise (certificat d'immatriculation) [Cost of the vehicle registration certificate]," <https://www.service-public.fr/particuliers/vosdroits/F19211>.
- [31] European Alternative Fuels Observatory. "Alternative fuels data for Spain," <https://www.eafo.eu/content/spain>.
- [32] European Alternative Fuels Observatory. "Alternative fuels data for Norway," <https://www.eafo.eu/content/norway>.
- [33] European Alternative Fuels Observatory. "Alternative fuels data for Italy," <https://www.eafo.eu/content/italy>.
- [34] Government of The Netherlands. "Wet op de motorrijtuigenbelasting 1994 Afdeling 3. Tarief bestelauto [Motor Vehicle Tax Act 1994 Section 3. Rate delivery van]," <http://wetten.overheid.nl/BWBR0006324/2017-01-01>.
- [35] Sénat: un site au service des citoyens [Senate: a site at the service of citizens]. "Mission "Écologie, développement et mobilité durables" (hors transports) et CAS "Aide à l'acquisition de véhicules propres" et "Transition énergétique" [Mission "Ecology, sustainable development and mobility" (excluding transport) and CAS "Aid for the acquisition of clean vehicles" and "Energy transition"]," <https://www.senat.fr/commission/fin/pjlf2017/np/np10a/np10a5.html>.

- [36] Government of The Netherlands. "Staatscourant van het Koninkrijk der Nederlanden; Wijziging van de Uitvoeringsregeling energie-investeringsaftrek 2001 [Government Gazette of The Netherlands; Amendments to the Implementation Regulation for the 2001 Energy Investment Allowance]," <https://zoek.officielebekendmakingen.nl/stcrt-2016-68749.html>.
- [37] L. I. S. o. t. R. o. A. (RIS), "Bundesrecht konsolidiert: Gesamte Rechtsvorschrift für Ökostrom-Einspeisetarifverordnung 2018," 2018.
- [38] Hychico. www.hychico.com.ar.
- [39] Belgium Commission Wallonne pour l'Énergie [Walloone Commission for Energy]. "Gaz issus de renouvelables [Renewable gases]," <https://www.cwape.be/?dir=4.2.05>.
- [40] M. J. A. STREITNER., "Wasserstoffstrategie für Österreich Verbund EU-Energieforum," ÖVGW Richtlinie G31; Wasserstoffstrategie für Österreich Verbund EU-Energieforum, 2019.
- [41] Green Gas Grids. "Overview of biomethane markets and regulations in partner countries," 2020; https://ec.europa.eu/energy/intelligent/projects/sites/iee-projects/files/projects/documents/greengasgrids_overview_of_biomethane_markets.pdf.
- [42] GRDF, GRTgaz, SPEGNN *et al.* "Renewable gas: French panorama 2016," 2020; <http://www.grtgaz.com/fileadmin/medias/communiqués/2017/EN/Renewable-gas-french-panorama-2016.pdf>.
- [43] Rijksdienst voor Ondernemend Nederland [Industry Agency of The Netherlands]. "Biomassa Stimulerende Duurzame Energieproductie (SDE+) [Stimulation of Sustainable Energy Production : Biomass]," <https://www.rvo.nl/subsidies-regelingen/stimulerende-duurzame-energieproductie/categorie%C3%ABn/biomassa-sde>.
- [44] B.-E. V. Sam Tessens. "Transbio Project, WP 2: Scenario-analyse op basis van technische beschrijving — Steunmechanismen voor Biomethaan in Nederland [Transbio Project, WP 2: Scenario analysis based on technical description - Support mechanisms for Biomethane in the Netherlands]," 2020; https://www.biogas-e.be/sites/default/files/2017-08/WP2_D2-6_biomethaan-Nederland.pdf.
- [45] UK Government Office of Gas and Electricity Markets. "Non-Domestic RHI tariffs and payments," <https://www.ofgem.gov.uk/environmental-programmes/non-domestic-rhi/contacts-guidance-and-resources/non-domestic-rhi-tariffs-and-payments>.
- [46] République Française - Ministère de la transition écologique et solidaire. "La réglementation de la prévention des risques et de la protection de l'environnement: 4715. Hydrogène (numéro CAS 133-74-0) 4.7 Substances et mélanges nommément désignés [Risk avoidance and environmental protection regulations: 4715. Hydrogen (CAS number 133-74-0) 4.7 specifically designated substances and mixtures]," https://aida.ineris.fr/consultation_document/30090.
- [47] République Française - Ministère de la transition écologique et solidaire. "La réglementation de la prévention des risques et de la protection de l'environnement: 3420. Fabrication de produits chimiques inorganiques [Risk avoidance and environmental protection regulations: 3420. Manufacture of inorganic chemicals," https://aida.ineris.fr/consultation_document/25136.
- [48] Agencia Estatal Boletín Oficial del Estado del Spain. "Boletín Oficial del Estado, Num. 296, Miércoles 11 de diciembre de 2013, Sec. I. Pág. 98151, Ley 21/2013, de 9 de diciembre, de evaluación ambiental [Official State Gazette, Num. 149, Friday June 23, 2017, Sec. I. Page 51631, Law 21/2013, of December 9, on environmental evaluation]," <https://www.boe.es/boe/dias/2013/12/11/pdfs/BOE-A-2013-12913.pdf>.
- [49] Agencia Estatal Boletín Oficial del Estado del Spain. "Boletín Oficial del Estado, Sábado 31 de diciembre de 2016, Sec. I. Pág. 91806: Real Decreto Legislativo 1/2016, de 16 de diciembre, por el que se aprueba el texto refundido de la Ley de prevención y control integrados de la contaminación. [Royal Decree

- 1/2016, of December 16, approving the revised text of the Integrated Prevention and Control Law of contamination.]," <https://www.boe.es/boe/dias/2016/12/31/pdfs/BOE-A-2016-12601.pdf>.
- [50] European Union Network for the Implementation and Enforcement of Environmental Law. "Supporting Implementation of the Industrial Emissions Directive (2010/75/EU): Final Report: 2015-12-06," 2020; <https://www.impel.eu/wp-content/uploads/2015/08/FR-2015-01-Supporting-IED-Implementation.pdf>.
- [51] P.-T. B. (PTB). "Publikationen: "Gesetzliches Messwesen" [Publications: "Legal Metrology"]," <https://www.ptb.de/cms/ptb/fachabteilungen/abt9/fb-92/ag-921/921-publikationen.html>.
- [52] ENARGAS, "NAG-602, Norma de Calidad de Gas Natural," 2019.
- [53] Engie et al. "GRHYD: Renouvelons nos énergies [GRHYD Project: Renew our energy systems]," <http://grhyd.fr/>.
- [54] HyDeploy project. "Hydrogen is vital to tackling climate change," <https://hydeploy.co.uk/>.
- [55] T. D., D. Mertens, M. Meeus *et al.* "Power-to-Gas Roadmap for Flanders, Final Report, Oct 2016," 2020; https://www.waterstofnet.eu/_asset/_public/powerogas/P2G-Roadmap-for-Flanders.pdf.
- [56] K. Altfeld, and D. Pinchbeck. "Admissible hydrogen concentrations in natural gas systems," ISSN 2192-158X; https://www.gerg.eu/wp-content/uploads/2019/10/HIPS_Final-Report.pdf.
- [57] European Biogas Association (EBA). "[*** to be confirmed ***]," <https://www.europeanbiogas.eu/> [*** to be confirmed ***].
- [58] GRTgaz, "GRTgaz prescriptions, *Operational Code for Network Routing*," 2018.
- [59] A. E. B. O. d. E. d. Spain, "Boletín Oficial del Estado, Num. 238, Lunes 3 de octubre de 2011, Sec. I. Pág. 103888, Resolución de 22 de septiembre de 2011, de la Dirección General de Política Energética y Minas, por la que se modifica el protocolo de detalle PD-01 «medición» de las normas de gestión técnica del sistema gasista [Resolution of September 22, 2011, of the General Directorate of Energy Policy and Mines, which modifies the protocol of detail PD-01 «measurement» of the technical management standards of the gas system]," 2011.
- [60] R. v. O. N. I. A. of, and T. N.], "Kamerbrief over het langetermijnbeleid over gassamenstelling [Letter to Parliament on the long-term policy on gas composition]," 2012
- [61] UK Government Health and Safety Executive (HSE). "A guide to the Gas Safety (Management) Regulations 1996," 2020; <https://www.hse.gov.uk/pUbns/priced/I80.pdf>.
- [62] FCHJU, "A roadmap for financing hydrogen refueling networks – Creating prerequisites for H2-based mobility," 2013.
- [63] E. Commission, "Directive 2014/94/EU of the European Parliament and of the Council of 22 October 2014 on the deployment of alternative fuels infrastructure," 2014.
- [64] H. Europe, "HyLAW Online Database," 2020.
- [65] C. Philibert. "Renewable energy for industry: From green energy to green materials and fuels," <https://webstore.iea.org/insights-series-2017-renewable-energy-for-industry>.
- [66] A. De Vita, and *et al.*, *Sectoral integration - long-term perspective in the EU Energy System*, 2018.
- [67] N. R. E. Laboratory, "H2 at scale: Deeply Decarbonizing Our Energy System," 2016.
- [68] Hydrogen Council. "Hydrogen scaling up, A sustainable pathway for the global energy transition," <https://hydrogencouncil.com/wp-content/uploads/2017/11/Hydrogen-scaling-up-Hydrogen-Council.pdf>.
- [69] H. Council, "How hydrogen empowers the energy transition," 2017.

- [70] O. Tlili, "Rethinking the way to decarbonize the energy system: prospective study of hydrogen market attractiveness," 2017.
- [71] E. v. M. K. z. E. Deutscher Verein des Gas und Wasserfaches, "Speicherung und Einspeisung von Wasserstoff und Methan in Erdgasnetz," 2013.

CHAPTER IV

Part 1: Subtask 3A: Review and analysis of the existing techno-economic studies on PtH and HtX

Authors: Jochen Linssen¹, Christine Mansilla², Abhilash Bandam¹, Mihai Balan³, Francesco Dolci⁴, Robert R Dickinson⁵, Carlos Fúnez Guerra⁶, Rupert Gammon⁷, Laurence Grand-Clément⁸, Henrik Iskov⁹, Jonathan Leaver¹⁰, Emilio Nieto Gallego⁶, Andre Pereira¹¹, Joris Proost¹², Christopher Quarton¹¹, Sheila Samsatli¹¹, Olfa Tlili², Solène Valentin¹³, Detlef Stolten¹, Paul Lucchese², Martin Robinius^{1*}.

Affiliations:

- (1) Forschungszentrum Jülich GmbH, Techno-economic Systems Analysis (IEK-3), Germany;
- (2) CEA, Université Paris Saclay, France;
- (3) Institute for Cryogenics and Isotopic Technologies ICSI, Romania;
- (4) Joint Research Centre of the European Union;
- (5) Hydricity Systems and University of Adelaide, Centre for Energy Technology, Australia;
- (6) Centro Nacional del Hidrógeno, Spain;
- (7) De Montfort University, UK;
- (8) PersEE, France;
- (9) Danish Gastechology Centre A/S, Denmark;
- (10) Unitec Institute of Technology, New Zealand,
- (11) Department of Chemical Engineering, University of Bath, UK;
- (12) Université Catholique de Louvain, Division of Materials and Process Engineering, Belgium;
- (13) Air Liquide, France.

**corresponding author: Jochen Linssen, Forschungszentrum Jülich GmbH, Wilhelm-Johnen-Straße 1, D-52428 Jülich, Phone: +49 2461 61-3581, email: j.linssen@fz-juelich.de*

After addressing the regulatory framework and its impact on P2X systems deployment, the next chapter addresses the techno-economic aspect. The first part suggests a general review of techno economic studies addressing P2X pathways. Then, in the following parts, focus is put on the production side (PtH),

analyzing the electrolysis systems (CAPEX, size impact, etc.) and their interaction with the electricity system (services to the electricity grid).

Key messages

- Low-carbon H₂ can play a role in the electric, gas, transport, and industry sectors.
- This chapter presents an approach for a collaborative review of Power-to-X pathways available in literature, considering policy papers and studies from national and international agencies, industry and NGOs
- The review identified clear cost reduction trends for hydrogen production by electrolysis
- The cost-reduction potential for PEM electrolysis appears more promising than AEL.

Abstract

The application of Power-to-Hydrogen Hydrogen-to-X (or Power-to-X PtX) concepts for managing demand, providing seasonal storage, and linking the end use sectors to low-carbon electricity generation has attracted significant interest during the last decade.

This chapter presents an approach for a collaborative review of Power-to-X pathways available in literature, considering policy papers and studies from national and international agencies, industry, and NGOs, published before 2017. The review is based on over 220 national and internationally published studies and reports.

This collaborative review process was performed by an international team of experts as a two-step approach. The identified publications are first evaluated, and then the selected publications are analyzed in depth.

Notwithstanding assumed rising electricity costs of up to 50% from today to the period 2030 to 2050, the review identified clear cost reduction trends for hydrogen production by electrolysis: starting with an average at over 10€/kg_{H₂} for the period before 2020, the production costs estimate decrease to 3.2€/kg_{H₂} in the period 2031 to 2050. The decrease in hydrogen production costs can be explained by increasing efficiencies in combination with significantly lower costs for all electrolysis technologies. The assumed efficiencies for alkaline electrolysis (AEL) and proton exchange membrane (PEM) electrolysis improve reaching an average value of 68% for the period 2030 to 2050. The specific investment for AEL and PEM goes down to 640€/kW_{el} and 440€/kW_{el} respectively. The cost-reduction potential for PEM electrolysis appears more promising than AEL.

The review of applied pathways identifies Hydrogen-to-Gas by synthetic methane, Hydrogen-to-Gas by direct use of hydrogen, Hydrogen-to-Fuel by hydrogen conversion to transport fuels and Hydrogen-to-Power by re-electrification of hydrogen. PtX for industrial use of hydrogen and Power-to-Liquids are not the focus since there are no available reviewed publications before the 2017 cut-off date.

Keywords

- Power-to-Hydrogen
- Hydrogen-to-X
- Power-to-Gas
- Hydrogen Markets
- Collaborative review

Introduction

The application of Power-to-Hydrogen (PtH) concepts for managing demand, providing seasonal storage, and supplying transport, industry, households, and small consumers with carbon-free energy carriers has attracted significant interest during the last decade. This concept supports the integration of Variable Renewable Energy Sources (VRES) by converting electricity to hydrogen in times of high VRES electricity generation to make that energy storable and tradeable. In addition, chemical energy carriers such as hydrogen can also facilitate large-scale and long-term storage due to their high energy density, very high storage capacities due to the possible use of geological storage sites, and comparatively low storage costs [1].

Further down the value chain, hydrogen can be deployed in a large portfolio of applications – referred to here as “Hydrogen-to-X” (HtX). Figure 18 summarizes the different options and the generation, conversion, and infrastructure parts of the pathways.

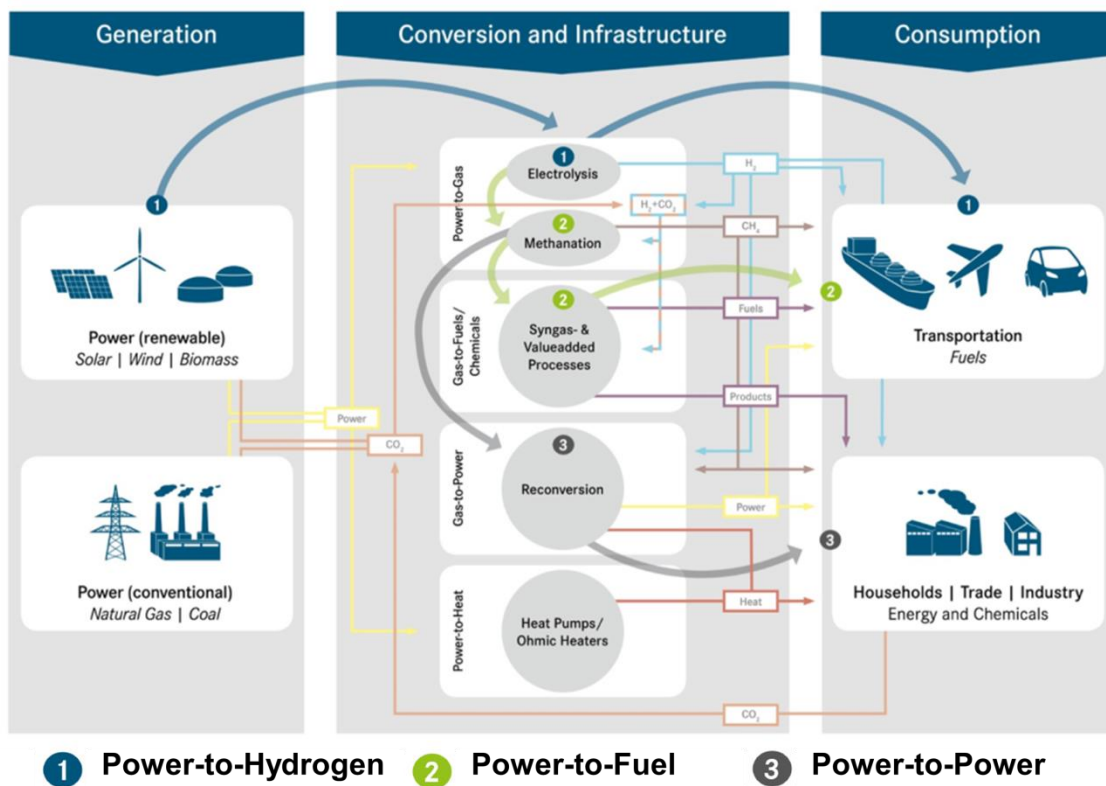

Figure 18: Schematics of pathways of PtX [2]

In the broadest sense, all the pathways from Power-to-Hydrogen Hydrogen-to-X, where X refers to the many and diverse end-point applications, are commonly shortened to simply Power-to-X (PtX). Note that Power-to-Gas (PtG) can be used in the literature to refer to PtH systems or both HtG-M and HtG-H₂ pathways. A categorization of many but not all of these pathways is presented by Dickinson et al. (2017) [3].

There is a considerable amount of literature analyzing future energy systems, including the future potential of PtX concepts. For example, Saba et al. have undertaken a review of electrolysis [4] and Ghaib et al. of methanation [5]. Detailed reviews of PtX demonstration projects have been prepared by Chehade et al. on a worldwide level [6] and by Wulf et al. for Europe [7]. However, despite the vast literature available, a systematic overview and a comprehensive understanding of the various technical and economic pathways for PtH and HtX applications, under the diverse scenarios and policy schemes, is still lacking.

The novelty of this study lies in the collaborative review involving several experts and the integration of policy papers and studies coming from industry and NGOs written in languages other than English. The approach allows for consideration of national and international policy strategies in the implementation of PtX. This goes beyond scientific papers and incorporates publications of national and international agencies, governments, NGOs and industries.

In this chapter, an international network of experts under the umbrella of Task 38 “Power-to-Hydrogen and Hydrogen-to-X” of the International Energy Agency’s Hydrogen Technology Collaboration Program [8] assesses the techno-economic potential of Power-to-Hydrogen pathways as available in the literature for the period 1999 to 2017. The review of 220 national and internationally published studies (see Table 4; Appendix) was carried out by over 15 international hydrogen experts, based on a consistent and transparent assessment process. The review undertaken for this work does not seek to examine an exhaustive list of all hydrogen studies. Rather, the aim has been to capture the diversity of the current state of studies undertaken so far.

The paper is structured by the description of the designed methodology for task sharing and the cooperative review process (Methodology for a structured international and collaborative review). This includes a two-step approach for selecting scenario studies for a detailed review. Following this, Detailed analysis of review Step 2, provides an analysis of the general and techno-economic parameters of the reviewed scenario studies in the literature. Based on this analysis, general trends and possible technical and economic pathways to markets are identified. A special focus of the review was given to Power-to-X pathways in future scenarios and their associated costs for hydrogen production, including electricity and electrolyzer costs.

Methodology for a structured international and collaborative review

A shared literature review performed by a variety of discipline experts from different countries requires a general understanding of the topic and a clear definition of the objective and used terms. A structured representation of data input and a precise definition of analyzed parameters for such a process are mandatory.

The process of gathering literature was based on inputs from the international review team. The international composition of the panel of experts allowing a wide range of literature review is the strength of this exercise. Approximately 15 % of the reviewed literature is published in languages other than English (e.g. Dutch, German, Danish and French). Twelve were not captured due to a lack of translation. .

The review process is a two-step approach. Given the large number of identified documents, the first review step evaluates the publications according to key criteria, including:

- the context of the study and general issues: date, type of document, geographical scope and time horizon;
- the crucial issues and bottlenecks in publications identified with respect to Power-to-X pathways.

This approach allows the screening of publications that do not fit the objective of the review: which revolves around the previously listed PtX and HtX pathways. Based on these criteria, a nominated reviewer decides whether the document will be subject to a second review step by applying the following criteria: (i) a clear focus of the publication on the techno-economic potentials of PtH – HtX pathways and (ii) a proper documentation of techno-economic assumptions and results.

In step 1 of the review process, 220 publications (for the list of publications see Appendix 1 – Table 1) are checked for suitability and for a detailed analysis of techno-economic parameters. The types of publication are categorized as: peer-reviewed journal articles and discussion papers; study reports issued by companies, research organizations, governmental or regional bodies; conference proceedings, presentations, and short articles targeting policy makers (

Figure 19).

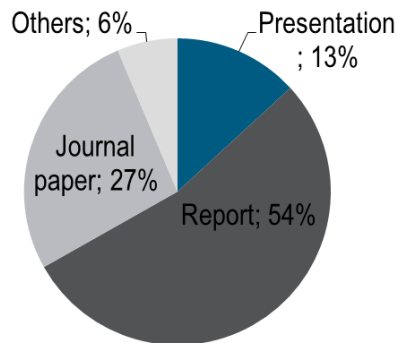

Figure 19 Results of review step 1: types of document collected (sum of eligible publications: 220)

Figure 20 displays the breakdown of reviewed documents, according to the publication date. The decrease in 2017 is due to the fact that the collection process of documents ended before the end of the year. More than 70% of the reviewed documents were published in the past 7 years with a clear peak in the years 2013 and 2014, announcing the recent momentum for PtH and HtX pathways. Indeed, numerous studies and reports were published afterwards by international and renowned organizations ([9], [10], [11], etc.), highlighting an exponential interest in P2X pathways.

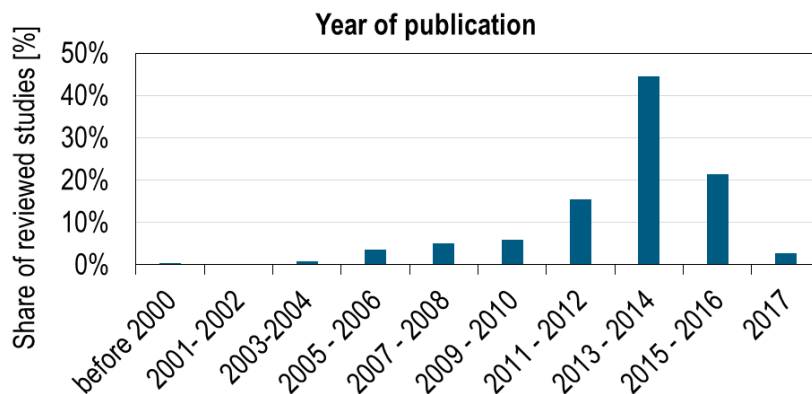

Figure 20 Results of review step 1: Publication years of collected documents (sum of eligible publications:220)

Although publications are most often written in English (85% of the reviewed documents), the regional coverage is broad. As depicted in Figure 21, 18 countries or supra-regions are identified among the publications. Approximately 70% deal with a specific national or supra-regional context.

By country

By supra-region

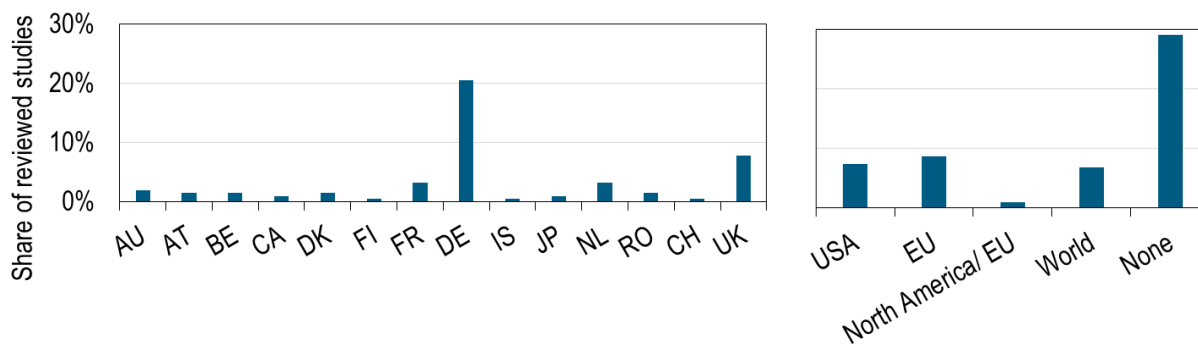

Figure 21 Results of review step 1: Geographical scope of the studies (sum of eligible publications: 220)

The review process was centrally organized and controlled by a single lead reviewer. Step 1 of the review process was performed by completing structured fact sheets to capture general data of the publication and its applicability to PtH – HtX pathways.

The second review step involved the in-depth analysis of suitable publications from step1. Out of 220 publications, 166 publications were selected to be eligible for further analysis. A fundamental part of the in-depth analysis of step2 is a common understanding of the review goals and a detailed definition of parameters and common reading scheme. These two initial parts of the in-depth review process are essential to derive information in a transparent, comparative, and standardized way. The challenge is to make different data comparable irrespective of different regions, units, and timeframes. Some of the publications consider different scenarios with variable regimes and assumptions about techno-economic data, e.g. applied electrolyzer types, electrolyzer costs or electricity costs in a time-step dependent way. A special focus of review in step 2 is on identifying and extracting:

- addressed PtH – HtX pathways;
- main techno-economic assumptions of the PtH pathways:
 - assumed electricity prices,
 - type of applied electrolyzer, efficiency and CAPEX,
 - electrolyzer load factor,
 - hydrogen cost.
- main techno-economic assumptions of the HtX pathways:
 - efficiency of the pathways and costs. ;
- comparison of markets and business cases.

As most of the scenarios (in step 2) do not offer all information about the above-mentioned criteria, the number of eligible studies varies considerably, depending on the parameter being analyzed. However, it remained interesting to provide insights about the most common assumptions in the literature. The results are presented and discussed in the next section.

Detailed analysis of review Step 2

The selection process of publications in step1 reduces the full set of publications to 166 suitable publications with 224 scenarios. The time horizon of the publications and the assumed PtX pathways in their respective scenarios is broad. Roughly 1/3 of the publications describe the current situation of PtX technologies while 25% of the scenarios give parameters for the time period 2020 – 2030 and 20% for the long-term period 2030 – 2050 respectively. The rest of the selected publications represent more general studies describing business models or technology trends and do not give any information about the time frame of their analysis.

In the following subsections, the results of the analysis of the underlying electricity generation, electrolysis and efficiencies are described in detail. The techno-economic analysis is completed by a comparison of possible application cases for PtX pathways. The analysis is based on showing histograms of parameter classes with varying numbers for the eligible scenarios.

Electricity Supply

The PtH step implies the use of electricity to produce hydrogen. This process (water electrolysis) is based on the electrochemical splitting of water using electricity as the energy input. Therefore, the generation of electricity and the system integration of electrolysis are essential for the efficiency and costs of all PtX pathways.

The concept for electrolysis integration derives from a variety of electricity sourcing strategies, from coupling a full portfolio of generation technologies, including fossil, nuclear and Renewable Energy Sources (RES), to off-grid applications with high regard to dynamic behavior.

The left chart of Figure 22 shows the histogram of the assumed concepts for electrolysis integration for all 79 scenarios that include the relevant information. More than 70% of the eligible scenarios imply a full grid integration of electrolysis without direct coupling to RES. Only 15% of the analyzed scenarios take a direct coupling of RES and surplus electricity into account.

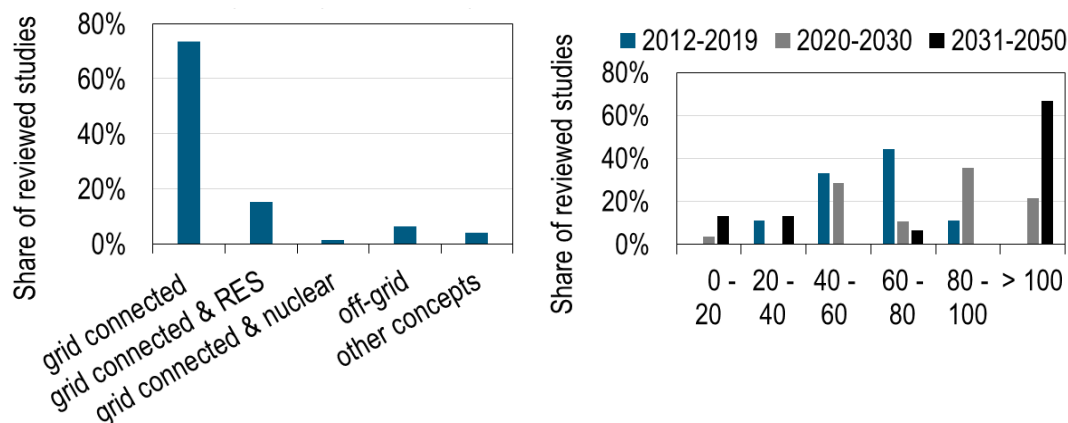

Figure 22 Left: Assumed electricity supply system for electrolysis (79 eligible scenarios);
 Right: Assumed electricity costs for different scenarios' timeframes (42 eligible scenarios)

The analysis of the assumed specific electricity costs (right chart of Figure 22) illustrates a large bandwidth. The average electricity costs in eligible PtX scenarios begins in the period 2012 to 2019 with 63€/MWh, rising to approximately 82€/MWh and rises up to 95€/MWh in the periods 2020-2030 and 2031- 2050, respectively. In the majority of scenarios, this trend is explained by the rising share of RES electricity generation.

Electrolysis

The central part of all PtX pathways is the electrolysis to produce hydrogen from electricity. A detailed description of the status quo of the technology and expected trends is, for instance, prepared by Carmo et al [12] but is not within the focus of this paper.

This section analyzes the types, costs, and efficiencies of electrolysis in the analyzed scenarios. The applied type of electrolysis (i.e. AEL, PEM, solid oxide electrolysis cells (SOEC)) is summarized in Figure 23. The histogram reveals a slight tendency towards AEL in all periods. Prior to 2030, SOEC is of minor importance. For the period 2031- 2050 the application of SOEC is seen as more viable and reaches the same range as AEL and PEM. This fact reflects the lower degree of maturity of this technology. The type of electrolysis is not specified in a large number of studies, probably since AEL and PEM characteristics (CAPEX, electricity consumption) are expected to converge in the medium term [13].

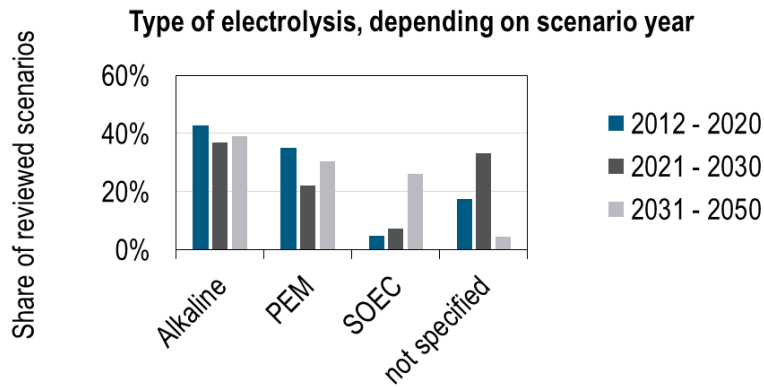

Figure 23. Type of electrolysis technology assumed in analyzed scenarios (109 eligible scenarios)

Regarding the specific cost for electrolyzers, Figure 24 shows a clear cost trend for the AEL and PEM technologies. Starting from a large distribution of specific cost between 750 €/kW_{el} up to over 2000 €/kW_{el} for AEL and 1000 up to over 2000 €/kW_{el} for PEM; costs decrease for AEL to an average value of 640 €/kW_{el} and to 440 €/kW_{el} for PEM, respectively, in the period 2031 to 2050. The cost reduction potential of PEM is seen to be more promising in the reviewed scenarios than AEL, but it starts at a higher level. It should be noted that the number of eligible scenarios, especially for PEM deployment, is low, and average values are influenced by high range within these scenarios. The cost trends for SOEC cannot be derived due to the lack of data. Regardless of the type of electrolysis considered, 95% of scenarios foresee a specific cost for electrolysis below 750 €/kW_{el}.

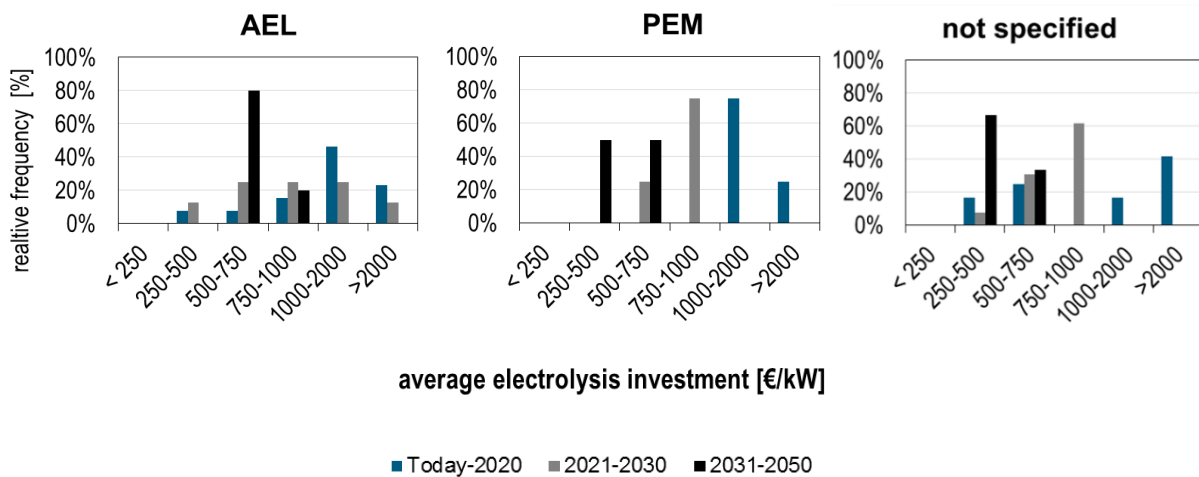

Figure 24. Average input specific electrolysis investment (eligible scenarios AEL: 26; PEM: 12; not specified: 28)

Figure 25 shows the histogram of the average electricity demand for hydrogen production. All technologies start with a high variability of specific electricity demand (between 45 and 65 kWh_{el}/kg_{H2}), but there is a clear trend towards higher efficiencies. The review reveals a similar efficiency range for AEL and PEM in the future. The average efficiency for AEL and PEM electrolysis is 50-51 kWh_{el}/kg_{H2} for the period 2030-2050.

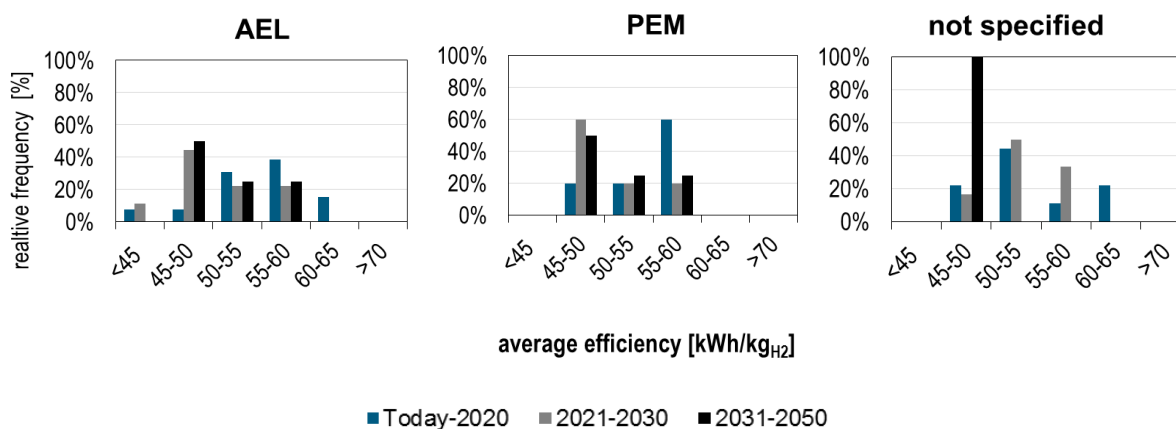

Figure 25: Average electricity demand for hydrogen production (eligible scenarios AEL: 26; PEM: 14; not specified: 16)

The resulting hydrogen production costs are impacted by electricity costs, CAPEX and OPEX of the electrolyzers, and the load factor of the electrolysis operation. The load factor is dependent on the assumed level of integration and can influence the resulting hydrogen production costs significantly. Figure 26 (left) shows the range in load factors in the various studies. Our review reveals a high range of assumed load factors in the scenarios depending on the configuration (e.g. on grid, off grid, RES coupled). No clear trend in time can be identified for this important operation criterion. The low number of eligible scenarios shows the lack of temporal resolution of production/generation data over the year in many scenario studies.

The right histogram of Figure 26 shows the trend in hydrogen production costs in different periods. The review of eligible scenarios reveals a large spread in the resulting hydrogen production costs.

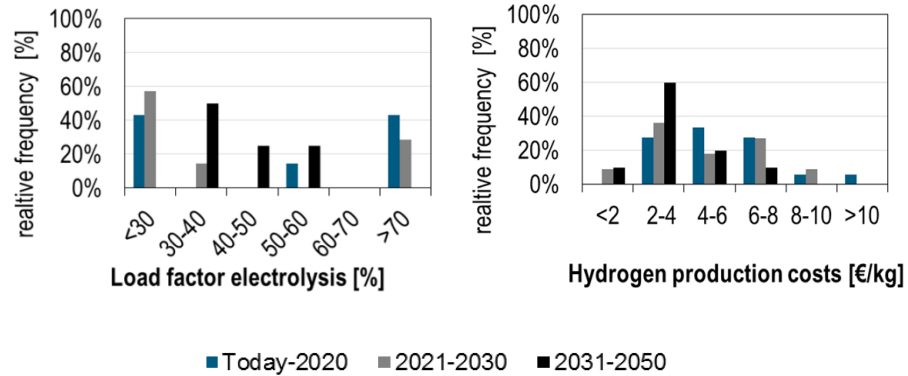

Figure 26 Average load factor of electrolysis (eligible scenarios: 14) and hydrogen production costs (eligible scenarios: 39)

Table 1: Average hydrogen production cost by period

Period	Average hydrogen production costs of eligible scenarios [€/kg]
Today - 2020	7.8
2020-2030	4.7
2030-2050	3.2

The cost range is from under 2 €/kg_{H2} to over 10 €/kg_{H2} depending on assumed electricity costs, electrolyzer capital costs, etc. The average hydrogen production costs of all eligible scenarios show a clear decrease over the time horizon (Table 1). Average production costs in the period 2031-2050 are 3.2 €/kg_{H2}.

Power-to-X pathways

Of the 166 publications, more than 85% see PtX as a possible option for conversion, storage or sector coupling. Hydrogen has the potential to be used in various applications in the conversion and final consumption in the electricity, gas, transportation, residential and industrial sectors [14]. The distribution of HtX downstream pathways in the publications are shown in

Figure 27.

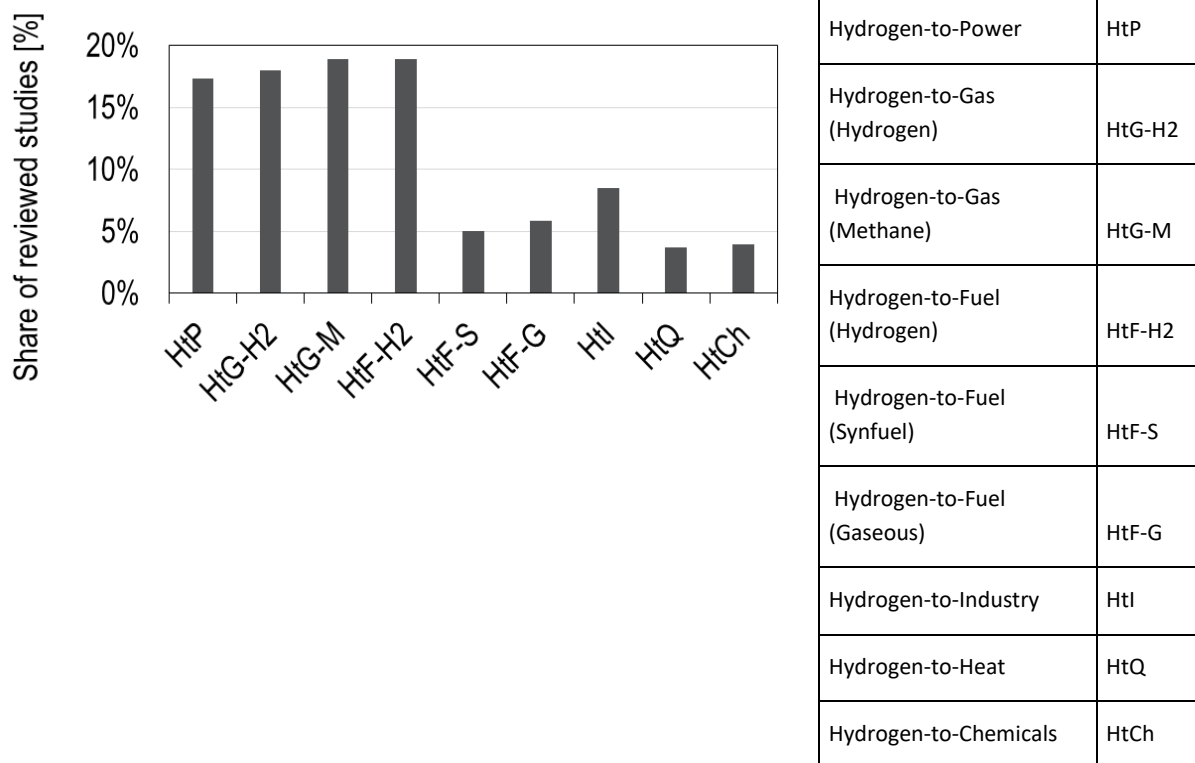

Figure 27. Addressed H-t-X pathways in the reviewed scenarios (multiple nomination possible)

Drawing conclusions from the studies is not a straightforward task, since the techno-economic analyses of the different scenarios are tightly linked to specific local contexts, as highlighted in Decourt et al. (2014) [15]. However, three major potential markets emerge out of the analyzed literature:

- Hydrogen-to-Gas: either by injection of synthetic methane produced by a methanation step, or by direct injection of hydrogen into the natural gas grid
- Hydrogen-to-Fuel: pure hydrogen as transportation fuel in various modes,
- Hydrogen-to-Power: re-electrification of hydrogen in thermal power plants or fuel cells.

The need for decarbonization of the transport sector provides a very strong incentive for producing low-carbon fuel, as can be seen by the inclusion of HtF pathways in almost 30% of the studies reviewed (around 65% of which corresponding to the direct use of hydrogen as a fuel, HtF-H2). Switching to hydrogen and electricity for transportation can improve air quality and reduce greenhouse gas emissions over the long term [16]. According to the UK H₂ Mobility report [17], the CO₂ emissions of hydrogen-fueled vehicles could be 75% lower than for equivalent diesel vehicles and facilitate a trajectory to zero CO₂ emissions by 2050. In the short term, the use of “green hydrogen” (i.e. hydrogen produced by low-carbon pathways)

in refineries is also a promising option for reducing the greenhouse gas intensity of established transport fuels [18].

Apart from the transport sector applications, blending hydrogen from PtH pathways with natural gas (in its pure form or as synthetic natural gas via methanation) is another popular pathway, being considered in 37% of the review studies. The overall potential, economic feasibility, and limitations still need to be examined closely, despite the work carried out so far [16]. The production and injection of synthetic natural gas (PtG) is more expensive than injecting pure hydrogen to form a blend (HCNG) [19] [20] [21]. PtG can utilize existing infrastructure with almost no modification. In contrast, HCNG is currently limited to values (depending on various factors) between 2-10% by volume [21] [16]. Industrial users are especially sensitive to variable hydrogen injection rates. However, the available estimations reviewed conclude that commercial competition is out of reach for synthetic methane blending, in particular in comparison with potential low-carbon options such as biomethane [19]. To become market competitive, direct injection of hydrogen from electrolysis would need low power prices along with tax exemption in order to foresee this pathway becoming economically attractive by 2050 [19]. Thus, in the mid-term, profitability is only possible with the support of government subsidies and/or premiums. Additionally, ENEA [19] and Thomas et al. [20] conclude that the electricity price and natural gas price have the most significant impact on the possible competitiveness of these business cases. To improve profitability, multimodal operation is frequently suggested. For example, participation in the heat market would improve the business case [21], selling oxygen and providing ancillary grid services would improve economics [20]. Another proposed option is the use of an integral “smart gas” system [22]. The smart gas systems, which are designed in a style similar to electrical smart grids, profit from increased flexibility and efficiency through multiple fuels and outputs. In particular, the option to deploy hydrogen or synthetic natural gas, as alternative energy carriers to electricity transmission, is often emphasized [20] [16].

Hydrogen can also enhance renewable energy integration [22]; HtP pathways were included in 17% of the studies in this review. Re-conversion of hydrogen to grid electricity is generally seen as a potentially viable option in the context of premium back-up or seasonal storage for systems with very high shares of renewables [23]. Particularly in instances exhibiting a very high share of renewable generation in addition to a shortage of conventional storage capacities (like pumped-hydro storage), hydrogen is expected to become the key solution for long-term storage [15]. For remote locations or energy supply systems strongly dominated by renewable energy sources, and therefore require longer-term energy storage (potentially displacing the need for fossil fuel to power during peak load periods concurrent with low VRE production), re-electrification of hydrogen is also likely to prove viable [16]. However, in the near-term, re-electrification schemes are expected to be economically challenging, primarily due to low round-trip efficiencies [16]. As such, re-conversion is projected to be last in the merit order of hydrogen end-uses [15]. Nevertheless, the path from water electrolysis to salt caverns and then to turbine, is anticipated to be the most cost-efficient technology for long-term storage [24]. In this case, the low cost of energy storage partially compensates for the round-trip losses [25]. Flexible operation of electrolyzers makes

them a controllable load. However, providing flexible-load services to the grid is in competition with many other competitive options [18]. Business cases are only possible by using all system services markets, and all market regimes need to be adapted. In all cases, the use of heat recovery can significantly improve overall system efficiencies [15].

Even if the economics prove difficult in the short term, the deployment of PtH–HtX pathways could be encouraged by policies (power tax exemption, feed-in tariffs for the gas grid, etc.) [26]. Regulations in support of such policies could be developed to limit the carbon intensity of energy services and products, thereby favoring low-carbon pathways within the electricity, transport, and heat sectors. Previous work tackled the incentives and legal barriers for power-to-hydrogen pathways [27].

In our review, around 8% of the publications address the hydrogen industrial use (HtI). However, no scenario was identified to quantify this use in the period 1999 – 2017. It is thus worth highlighting that momentum for industry applications has been observed recently, both at national [28] and international levels [29] [30]. At the international level, the IEA recently issued a report on the use of renewable electricity in different industry branches with a variety of applications [29]. This report emphasizes the potential role of ammonia produced by green hydrogen, either as a chemical feedstock, a process agent or as fuel [29]. Another recent trend addressed in techno-economic studies on hydrogen pathways (e.g. in [31]), is large-scale production of “green ammonia (which is easier” than hydrogen globally transported in existing shipping infrastructure. Other industrial routes include substituting natural gas with renewable-based hydrogen for direct iron reduction, or manufacturing methanol from renewables-based water electrolysis and recycled CO₂ [29]. Ultimately CO₂-free iron and steelmaking, and CO₂-free cement manufacturing, could be achieved. The use of recycled CO₂ for methanol production could even achieve carbon neutrality [29].

Discussion

The proposed two-step approach for a collaborative literature review has many advantages including task sharing, using broad language expertise and exploiting a large and diverse shared knowledge base. A drawback of this process is the time-intensive discussion process to arrive at a consensus on goals of the review, on definitions of terms used and on the design of a structure for the review process and resulting database.

A lesson learned from the collaborative and task-sharing review, is that a common understanding of the analyzed criteria and parameters, including interpretation, is deemed essential for success. In turn, a robust planning process is paramount. The two-step approach for identifying the most valuable reports is highly recommended for focusing on aspects to be analyzed.

Once the analysis aspects are identified, one major challenge of the review was to be able to compare data coming from the different documents.

In some cases, documentation of assumptions and quality of data was seen as an issue due to a lack of transparency in the process used in some publications. To address this problem, the experts decided applying a score for data quality for all analyzed publications. Figure 28 shows the histogram of the score of data quality. It is defined by a level of trust that was guided by a short description of quality standards. The average level of trust quantified by the experts is approximately 70% and the spread is high.

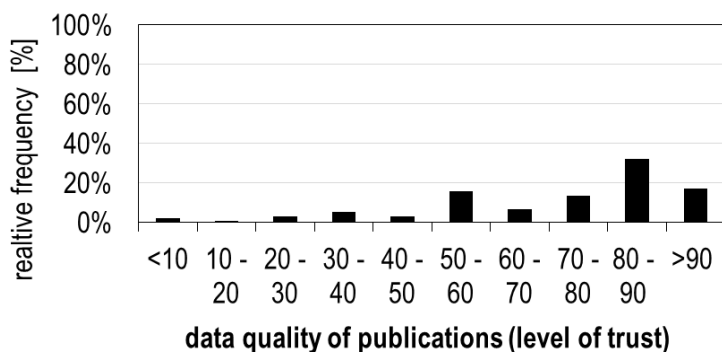

Figure 28. Experts evaluation of publication data quality expressed in level of trust (0 no; 100 full confidence)

Most of the publications have a confidence level higher than 50%. However, quality issues were noticed with some publications addressing the economic assessment of hydrogen systems. The comparison of cost data on an internal level is always combined with evaluation of currencies having variable exchange rates, different financial risks resulting in different WACCs (weighted-average cost of capital) for costs, and financing of technologies in different time periods. Most of the analyzed scenarios do not give any information about the mentioned criteria and weaken the basis for a transparent comparison of cost parameters.

Conclusion

‘Low-carbon’ hydrogen (i.e. produced through low-carbon pathways) can be used by many energy-consuming services. It has a potential role in the electricity, gas, transport, and industrial sectors. This paper presents an international and collaborative literature review of Power-to-Hydrogen and Hydrogen-to-X techno-economic studies. The aim is to capture the broad diversity within the current literature and draw some major conclusions from it. Over 220 documents were reviewed with a methodology developed to analyze a wide variety of studies. The two-step approach developed allows for a collaborative review by experts and the integration of policy papers and studies for industry and NGOs written in different languages.

The literature analysis revealed that the PtH – HtX topic is not only addressed through academic work, but also by regional studies undertaken by institutions or firms that investigate related business opportunities. The regional coverage is broad, and the timeframes varied from present to the medium and long term.

Although business cases are tightly linked with local circumstances, three major applications emerge from the literature: transportation, hydrogen-to-gas routes, and power generation. A momentum for industry applications has been observed only very recently, both at national and international levels. Overall, even if specific techno-economic studies are required to investigate business opportunities for diverse regional contexts, only approaches favoring synergies between sectors and acknowledging sector coupling can reveal the full potential of hydrogen to decarbonize the energy system.

Acknowledgements

The present work was carried out within the framework of Task 38 of the Hydrogen Technology Collaboration Program of the International Energy Agency. The task is coordinated by the Institute for techno-economics of energy systems (I-tésé) of the CEA, France supported by the ADEME. The literature review process was coordinated by Forschungszentrum Jülich GmbH, Techno-economic Systems Analysis (IEK-3), Germany.

Appendix

Table 4: Reviewed publications

Reference	Title of Study	Year of publication	Geographical scope
[32]	Survey of the Economics of Hydrogen Technologies	1999	World
[17]	UK H2 Mobility - Phase 1	2013	UK
[33]	Power-to-gas & Methanation – Pathways to a ‘Hydrogen Economy’	2014	UK
[34]	Hydrogen And Fuel Cell Opportunities For Scotland - The Hydrogen Energy Group Report	2006	Scotland
[14]	Blending Hydrogen into Natural Gas Pipeline Networks: A Review of Key Issues	2013	USA
[35]	Towards development of an Australian scientific roadmap for the hydrogen economy	2008	Australia
[36]	Hydrogen Production R&D: Priorities and Gaps	2006	None
[37]	Hydrogen as an energy carrier	2006	Belgium
[38]	State-of-The-Art Modelling of Hydrogen Infrastructure Development for the UK: Geographical, Temporal and Technological Optimization Modelling	2008	UK
[39]	Energy and the Hydrogen Economy	2010	None
[40]	Towards a hydrogen economy in Romania: Statistics, technical and scientific general aspects	2013	Romania
[41]	Hydrogen underground storage in Romania	2014	Romania
[42]	Exploring the role for power-to-gas in the future Dutch energy system	2016	World

[43]	Development of a technical and economic evaluation methodology for studying the implementation of Power-to-Gas in a specific case study	2016	Romania
[21]	Techno-economic implications of the electrolyser technology and size for power-to-gas systems	2016	Switzerland
[44]	‘Renewable’ hydrogen: Prospects and challenges	2011	World
[45]	Optimal design and operation of integrated wind hydrogen-electricity networks for decarbonising the domestic transport sector in Great Britain	2015	UK
[46]	Økonomisk/teknisk analyse af power-to-gas i energisystemet	2015	Denmark
[47]	Energikoncept 2030 – Sammenfatning	2015	Denmark
[48]	Global warming potential of hydrogen and methane production from renewable electricity via power-to-gas technology	2015	Europe
[49]	Hydrogen: A Future Energy Carrier?	2005	NONE
[50]	Hydrogen for Energy Storage	2014	USA
[51]	From “fuel to power”, to “power to fuel”	2016	Australia
[52]	Future Prospects and Public Policy Implications for Hydrogen and Fuel Cell Technologies in Canada	2005	Canada
[53]	Global Trends in Renewable Energy Investment 2015	2015	None
[16]	Hydrogen Energy Storage: Grid and Transportation Services	2015	USA
[54]	Hydrogen, Fuel Cells & Infrastructure Technologies Program	2007	USA
[55]	An Overview of Hydrogen Production and Storage Systems with Renewable Hydrogen Case Studies	2011	USA
[56]	The Green Vehicle Trend: Electric, Plug-in hybrid or Hydrogen fuel cell	2009	UK
[57]	Role of Hydrogen in Resolving Electricity Grid Issues	2015	France
[58]	Revisiting Energy Storage - There is a Business Case	2011	None

[59]	Systems Analyses Power to Gas	2013	Netherlands
[60]	Hydrogen-based Energy Conversion - More than storage: system flexibility	2014	None
[61]	Multi-objective Optimization of Batteries and Hydrogen Storage technologies for Remote Photovoltaic Systems	2010	None
[62]	Étude sur le potentiel du stockage d'énergies	2013	France
[13]	Development of Water Electrolysis in the European Union	2014	Europe
[63]	Etude portant sur l'hydrogène et la méthanation comme procédé de valorisation de l'électricité excédentaire	2014	France
[64]	Roadmap Power-to-Gas	2014	Dutch
[65]	The Role of Power-to-Gas in Achieving Germany's Climate Policy Targets with a Special Focus on Concepts for Road Based Mobility	2014	Germany
[25]	Commercialization of Energy Storage in Europe	2015	None
[66]	Hydrogen from renewable electricity: An international review of power-to-gas pilot plants for stationary applications	2013	World
[67]	Hydrogen energy and fuel cells - Strategic roadmap	2012	World
[68]	Trends in investments, jobs and turnover in the Fuel cells and Hydrogen sector	2013	None
[69]	Energy Storage Opportunities and Challenges	2014	USA
[70]	Grid Energy Storage	2013	USA
[71]	Power-to-Gas: The Case for Hydrogen	2015	USA
[72]	Prospects for Large-Scale Energy Storage in Decarbonized Power Grids	2009	None
[73]	The Value of Energy Storage for Grid Applications	2013	USA
[74]	Utility Scale Energy Storage Systems Benefits, Applications, and Technologies	2013	USA

[75]	Wind-to-Gas-to-Money? Economics and Perspectives of the Power-to-Gas Technology	2012	Germany
[76]	Effects of large-scale power to gas conversion on the power, gas and carbon sectors and their interactions	2015	Belgium
[77]	Energy Storage - Power to the People	2014	None
[78]	Hydrogen Infrastructure Market Readiness: Opportunities and Potential for Near-term Cost Reductions	2012	None
[79]	The Interaction Of A High Renewable Energy/Low Carbon Power System With The Gas System Through Power To Gas	2014	None
[80]	Power-to-Gas in transport - Status quo and perspectives for development	2014	Europe
[81]	Scenarios for deployment of hydrogen in contributing to meeting carbon budgets and the 2050 target	2014	None
[82]	Wind to Hydrogen in California: Case Study	2012	USA
[83]	Hydrogen Production for Solar Energy Storage	2011	None
[84]	Large Wind-Hydrogen Plants in Germany: The Potential for Success	2014	Germany
[85]	Power to gas: Technological overview, systems analysis and economic assessment for a case study in Germany	2015	Germany
[86]	E-storage: Shifting from cost to value Wind and solar applications	2016	World
[19]	The potential of Power-to-Gas	2016	Europe
[87]	Power-Electronic Systems for the Grid Integration of Renewable Energy Sources: A Survey	2006	None
[88]	Hydrogen and synthetic fuel production from renewable energy sources	2007	None
[89]	Wind energy and the hydrogen economy—review of the technology	2005	None

[90]	Renewable hydrogen production	2008	None
[91]	Hydrogen Production from Water Electrolysis: Current Status and Future Trends	2012	None
[92]	Entwicklung von modularen Konzepten zur Erzeugung, Speicherung und Einspeisung von Wasserstoff und Methan ins Erdgasnetz	2013	Germany
[93]	Synergien Gas- und Stromnetz	2015	Germany
[94]	Technoökonomische Studie von Power-to-Gas-Konzepten	2014	Germany
[95]	Nutzen von Smart-Grid-Konzepten unter Berücksichtigung der Power-to-Gas-Technologie	2015	Germany
[96]	Nutzen der Power-to-Gas-Technologie zur Entlastung der 110-kV-Stromverteilungsnetze	2015	Germany
[22]	Power-to-Gas Business Models in the United Kingdom	2013	UK
[97]	Energy storage systems - Strategic roadmap	2012	None
[98]	Strom Speichern	2014	None
[99]	Stromspeicher in der Energiewende	2014	Germany
[26]	Financing Hydrogen Projects - Business cases and political support	2012	World
[100]	Roadmap for Network Technologies and Services	2004	None
[101]	Application of technology roadmaps for renewable energy sector	2010	None
[102]	Renewable hydrogen energy regulations, codes and standards: Challenges faced by an EU candidate country	2012	None
[103]	Germany's "Energiewende" driving power-to-gas	2014	Germany
[104]	Moderne Stromspeicher - Unverzichtbare Bausteine der Energiewende	2012	None
[105]	Method for size optimization of large wind-hydrogen systems with high penetration on power grids	2013	None
[106]	Electricity storage: EU policies and targets: which legal and regulatory framework?	2012	None

[107]	Energy smart technologies - Hydrogen - Research note	2014	World
[108]	The application of different types of large scale energy storage systems in the Dutch electricity system at different wind power penetration levels	2013	The Netherlands
[109]	Hydrogen supply chain architecture for bottom-up energy systems models. Part 1: Developing pathways	2014	America/ Europe
[110]	Hydrogen supply chain architecture for bottom-up energy systems models. Part 2: Techno-economic inputs for hydrogen production pathways	2015	America/ Europe
[111]	The Mobility and Fuels Strategy of the German Government	2013	Germany
[112]	Monitoring report 2013	2014	Germany
[113]	Overview and tentative results of the HyUnder project	2014	Germany
[114]	Overview on all Known Underground Storage Technologies for Hydrogen	2013	Europe
[115]	Extended flexibility study - PtG potential in 2025 and 2030	2014	Europe
[116]	Roadmap for the Realization of a Wind Hydrogen Economy in the Lower Elbe Region	2013	None
[117]	Hydroprocessing: hydrotreating and hydrocracking	2014	None
[118]	Hydrogen energy storage	2012	Scotland
[119]	FCH JU Current achievements and future ambitions	2013	None
[120]	Integration erneuerbarer Energien in die deutsche Stromversorgung im Zeitraum 2015 – 2020 mit Ausblick 2025	2010	Germany
[121]	Eckpunkte einer Roadmap Power to Gas	2013	Germany
[122]	Power to Gas: Eine innovative Systemlösung auf dem Weg zur Marktreife	2013	Germany
[123]	Efficient integration of renewable energy into future energy systems	2011	None

[124]	Global screening of projects and technologies for Power-to-Gas and Bio-SNG	2013	World
[125]	Power to Gas Research Roadmap Offering a Solution to the Energy Storage Problem?	2013	None
[126]	DTU International Energy Report 2013 - Energy storage options for future sustainable energy systems	2013	World
[127]	Safety cost of a large scale hydrogen system for photovoltaic energy regulation	2013	France
[128]	Power-to-Gas: Gas in an integrated energy system	2013	Germany
[129]	Joint EASE/EERA recommendations for a European Energy Storage Technology Development Roadmap towards 2030	2013	Europe
[130]	Energy Storage Innovation in Europe - A mapping exercise	2013	None
[131]	Development of electricity storage in the national interest	2013	None
[132]	Alternative fuels for mobility and transport: harnessing excess electricity from renewable power sources with power-to-gas	2013	Austria
[133]	Electricity energy storage technology options	2010	None
[134]	The future role for energy storage in the UK	2011	UK
[135]	Energy Carriers for Powertrains for a clean and efficient mobility	2014	None
[68]	Power to Gas: Smart energy conversion and storage	2013	None
[136]	Storage and Grid Balancing Opportunities in the UK and German Grids Under Future Renewable-Energy Penetration Scenarios	2013	UK & Germany
118	The future role and challenges of Energy Storage		None
[137]	Hydrogen energy and fuel cells - A vision of our future	2003	None
[138]	Fuel Cell Distributed Generation Commercialization Study	2014	Europe
[139]	Urban buses: alternative powertrains for Europe	2012	Europe
[140]	Power-to-Gas Supporting the accommodation of renewable electricity	2013	Germany

[141]	H2 Mobilité France - Study for a Fuel Cell Electric Vehicle national deployment plan	2014	France
[142]	Water electrolysis and Renewable energy systems	2013	None
[143]	Clean flexible power using H2 storage	2014	UK
[144]	Energy Storage Technologies and Their Role in Renewable Integration	2012	None
[145]	Power-to-Gas: A Promising Solution to Integrate Large Quantities of Fluctuating Renewable Power	2013	None
[146]	Green Hydrogen and Power-to-Gas Technology - Mass Energy Storage for the Future Energy Market	2012	None
[147]	Polymer Fuel Cells – Cost reduction and market potential	2012	None
[148]	A perspective on the potential role of biogas in smart energy grids	2014	None
[149]	Production of Bio-methanol - Technology Brief	2013	None
[150]	Electrical Energy Storage	2011	None
[151]	Mixtures of hydrogen and methane in the internal combustion engine e Synergies, potential and regulations	2013	None
[152]	Natural gas in the energy transition	2014	None
[153]	Roadmap to renewable methane economy	2012	Finland
[154]	Power to Gas as an alternative energy storage solution to integrate a large amount of renewable energy: economic and technical analysis	2013	Europe
[155]	Die Rolle von Wasserstoff in der Energiewende	2014	None
[156]	Economic competitiveness of off-peak hydrogen production today - A European comparison	2013	Europe
[157]	Flexible hydrogen production implementation in the French power system: Expected impacts at the French and European levels	2015	Europe

[158]	Evaluation of power-to-gas as long-term storage concept regarding electricity and CO2 sources	2011	Germany
[159]	Technology roadmaps for transition management: The case of hydrogen energy	2012	None
[160]	Energiespeicherung in Erdgasnetzen Power-to-Gas	2011	Germany
[161]	Outlook of energy storage technologies	2008	None
[162]	Using the Existing Natural Gas System for Hydrogen	2009	Europe
[163]	Fuel Cell and Hydrogen technologies in Europe - Financial and technology outlook on the European sector ambition 2014- 2020	2011	Europe
[164]	Langfristszenarien und Strategien für den Ausbau der Erneuerbaren Energien in Deutschland bei Berücksichtigung der Entwicklung in Europa und global	2010	None
[165]	The Role of Energy Storage with Renewable Electricity Generation	2010	None
[166]	Fuel cells and hydrogen in a sustainable energy economy - Final report of the Roads2HyCom Project	2009	None
[167]	Industrial surplus hydrogen and markets and production	2007	Europe
[168]	Lessons Learned in Developing a Wind to Ammonia Pilot Plant	2012	None
[169]	Fuel Cell Electric Buses – Potential for Decarbonising Public Transport in Europe	2014	Europe
[170]	Analyse der Wirkung von Förderinstrumenten zur Marktintegration von Power to Gas in Deutschland	2013	Germany
[171]	Power-to-Gas coupling to biomethane production: a feasibility study	2013	None
[172]	Managing Temporary Oversupply from Renewables Efficiently: Electricity Storage Versus Energy Sector Coupling in Germany	2013	Germany
[15]	Electricity Storage	2013	None

[173]	Learning curves for hydrogen production technology: An assessment of observed cost reductions	2008	World
[174]	Power-to-Gas – A technical review	2013	None
[175]	Integration of Wind Energy, Hydrogen and Natural Gas Pipeline Systems to Meet Community and Transportation Energy Needs: A Parametric Study	2014	Canada
[176]	Electrolysis Systems for Grid Relieving	2016	Europe
[177]	Water Electrolysis Status and Potential for Development	2014	None
[178]	Power-to-Gas: Technology and Business Models	2014	Austria
[179]	Wege zur 100% erneuerbare stromversorgung	2011	Germany
[180]	Strategic Assessment of the role and value of energy storage systems in the UK low carbon energy future	2012	UK
[181]	Mobility Costs Analysis and Life Cycle Assessment of Power-To-Gas as Alternative Fuel	2011	Germany
[182]	Technology Innovation Needs Assessment (TINA) - Hydrogen for transport	2014	UK
[183]	The role of large scale energy storage systems in the electricity grid	2012	The Netherlands
[184]	The Potential of Power-to-Gas, the new Eureka	2013	The Netherlands
[185]	Uitdagingen en oplossingen voor waterstof als optie voor lange termijn energieopslag	2014	The Netherlands
[186]	Power-to-Gas Technology and Business Model Progress	2012	Japan
[187]	Residual Load, Renewable Surplus Generation and Storage Requirements in Germany	2013	Germany
[188]	Strom- und Gasmarktdesign zur Versorgung des deutschen Straßenverkehrs mit Wasserstoff	2016	Germany

[189]	Power to liquid and power to gas: An option for the German Energiewende	2015	Germany
[190]	Closing the loop: captured CO ₂ as a feedstock in the chemical industry	2015	Germany
[191]	Renewable Power-to-Gas: A technological and economic review	2014	Netherlands
[192]	Wasserstoff-Infrastruktur für eine nachhaltige Mobilität	2013	Germany
[193]	Hydrogen Delivery Technical Team Roadmap	2013	USA
[194]	Analyzing the Levelized Cost of Centralized and Distributed Hydrogen Production Using the H2A Production Model - Version 2	2009	World
[195]	The H2A Production Model	2008	None
[196]	Design and dimensioning of hydrogen transmission pipeline networks	2013	None
[197]	Design of a future hydrogen supply chain: snapshot model	2006	United Kingdom
[198]	The importance of economies of scale, transport costs and demand patterns in optimizing hydrogen fueling infrastructure: An exploration with SHIPMod (Spatial hydrogen infrastructure planning model)	2013	None
[199]	Soft-linking energy systems and GIS models to investigate spatial hydrogen infrastructure development in a low-carbon UK energy system	2009	None
[200]	Optimizing site selection for hydrogen production in Iceland	2008	None
[201]	Study on Introduction of CO ₂ -free Energy to Japan with liquid hydrogen	2015	Japan / Australia
[202]	Studie über die Planung einer Demonstartionsanlage zur Wasserstoff-Kraftstoffgewinnung durch Elektrolyse mit Zwischenspeicherung in Salzkavernen unter Druck	2015	Germany
[203]	Interaktion EE-Strom, Wärme und Verkehr	2015	Germany
[204]	Analyse von Power-to-Gas-Energiespeichern im regenerativen Energiesystem	2014	Germany
[205]	Hydrogen Delivery Infrastructure Options Analysis	2008	USA

[206]	Integration von Wind-Wasserstoff-Systemen in das Energiesystem	2014	Germany
[207]	Analyse des Klimaschutzpotentials der Nutzung von erneuerbarem Wasserstoff und Methan	2013	Germany
[208]	Production costs of alternative transportation fuels	2013	World
[209]	Prüfung der klimapolitischen Konsistenz und der Kosten von Methanisierungsstrategien	2014	Germany
[210]	Status and recommendations for RD&D on energy storage technologies in a Danish context	2014	Denmark
[18]	Short term and long term opportunities to leverage synergies between the electricity and transport sectors through power-to-hydrogen	2016	France and Germany
[211]	Metastudie zur Untersuchung der Potenziale von Wasserstoff für die Integration von Verkehrs- und Energiewirtschaft	2016	None
[212]	Power-to-gas systems for absorbing excess solar power in electricity distribution networks	2016	Germany
[213]	Using surplus nuclear power for hydrogen mobility and power-to-gas in France	2016	France
[214]	Connecting renewable generation sources: Managing the network with increasing renewables	2016	None
[215]	AEMO's Future Power System Security program; progress report	2016	None
[216]	Commercial Potential for Renewable Hydrogen In California	2016	None
[23]	The Effect of Power Renewables on the Grid in 20 Year Time	2016	None
[217]	A comparison between renewable transport fuels that can supplement or replace biofuels in a 100% renewable energy system	2014	None
[218]	Life cycle assessment of hydrogen production via electrolysis - a review	2012	None
[219]	Economic feasibility of pipe storage and underground reservoir storage options for power-to-gas load balancing	2015	Germany
[220]	Integrated Modeling and Assessment of the Operational Impact of Power-to-Gas (P2G) on Electrical and Gas Transmission Networks	2015	UK

[221]	Power to Gas – eine Systemanalyse	2014	Austria
[222]	Comparison of gas turbines and power-to-gas plants for improved wind park energy dispatchability	2015	None
[223]	Potential for large scale energy storage technologies - Comparison and ranking including an outlook to 2030	2015	Germany
[224]	Hydrogen storage for wind parks: A real options evaluation for an optimal investment in more flexibility	2014	Germany
[225]	A comprehensive model for the German electricity and heat sector in a future energy system with a dominant contribution from renewable energy technologies - Part II: Results	2014	None
[226]	Role of power-to-gas in an integrated gas and electricity system in Great Britain	2015	UK
[227]	Integration of Variable Renewable Energies in the European power system: a model-based analysis of transmission grid extensions and energy sector coupling	2013	Germany
[228]	Screening of power to gas projects	2016	World
[20]	Power to Gas Roadmap for Flanders	2016	Belgium
[229]	Power to Hydrogen Early business cases	2017	Europe
[230]	Economic Assessment of Hydrogen Technologies Participating in California Electricity Markets	2016	USA
[231]	California Power-to-Gas and Power-to-Hydrogen Near-Term Business Case Evaluation	2016	USA
[232]	Seasonal storage and alternative carriers: A flexible hydrogen supply chain model	2017	None
[233]	Power-to-Steel: Reducing CO ₂ through the Integration of Renewable Energy and Hydrogen into the German Steel Industry	2017	None
[2]	Linking the Power and Transport Sectors—Part 1: The Principle of Sector Coupling	2017	None

[234]	Linking the Power and Transport Sectors—Part 2: Modelling a Sector Coupling Scenario for Germany	2017	Germany
[24]	Spatio-Temporal Optimization of a Future Energy System for Power-to-Hydrogen Applications in Germany	2017	Germany

REFERENCES

1. Godula-Jopek, A., *Hydrogen production by electrolysis*. 2015, Wiley.
2. Robinius, M., et al., *Linking the Power and Transport Sectors-Part 1: The Principle of Sector Coupling*. *Energies*, 2017. **10**(7): p. 956.
3. Dickinson, R., et al., *Power-to-Hydrogen and Hydrogen-to-X pathways: opportunities for next generation energy systems*, in *14th International Conference on the European Energy Market (EEM 2017)*, . 2017: Dresden, Germany.
4. Saba, S.M., et al., *The investment costs of electrolysis – A comparison of cost studies from the past 30 years*. *International Journal of Hydrogen Energy*, 2018. **43**(3): p. 1209-1223.
5. Ghaib, K. and F.-Z. Ben-Fares, *Power-to-Methane: A state-of-the-art review*. *Renewable and Sustainable Energy Reviews*, 2018. **81**: p. 433-446.
6. Chehade, Z., et al., *Review and analysis of demonstration projects on power-to-X pathways in the world*. *International Journal of Hydrogen Energy*, 2019. **44**(51): p. 27637-27655.
7. Wulf, C., J. Linßen, and P. Zapp, *Review of Power-to-Gas Projects in Europe*. *Energy Procedia*, 2018. **155**: p. 367-378.
8. Lucchese, P. and et al. *Power-to-Hydrogen and Hydrogen-to-X: Midterm appraisal of the IEA HIA Task 38 accomplishments*. in *22nd World Hydrogen Energy Conference (WHEC 2018)* Rio de Janeiro, Brazil,.
9. International Energy Agency, *The Future of Hydrogen - Seizing today's opportunities in Technology report* 2019: Paris.
10. Council, H., *Path to hydrogen competitiveness - A cost perspective*. 2020.
11. IRENA, *Hydrogen: A renewable energy perspective*. 2020.
12. Carmo, M., et al., *A comprehensive review on PEM water electrolysis*. *International Journal of Hydrogen Energy*, 2013. **38**(12): p. 4901-4934.
13. Bertuccioli, L., et al., *Development of Water Electrolysis in the European Union*. Fuel Cells and Hydrogen Joint Undertaking (FCH JU) T4 - Final Report Y3 - 30.01.2019 M4 - Citavi.
14. Melaina, M.W., O. Antonia, and M. Penev, *Blending Hydrogen into Natural Gas Pipeline Networks: A Review of Key Issues*. 2013. 131.
15. Decourt, B. and R. Debarre, *Electricity storage*. *Leading the energy transition factbook*. Schlumberger Business Consulting (SBC) Energy Institute, Gravenhage, 2013.
16. Melaina, M. and J. Eichman, *Hydrogen Energy Storage: Grid and Transportation Services*. *Renewable Energy Laboratory*, 2015.
17. UK H2 Mobility, *UK H2 Mobility*. 2013.
18. Vanhoudt, W., et al., *Power -to-gas short term and long term opportunities to leverage synergies between the electricity and transports sectors through power-to-hydrogen*. LBST; HINICIO, 2016.

19. Enea Consulting, *The Potential of Power-to-Gas*. 2016.
20. Thomas, D., et al., *Power to Gas Roadmap for Flanders*. 2016.
21. Parra, D. and M.K. Patel, *Techno-economic implications of the electrolyser technology and size for power-to-gas systems*. International Journal of Hydrogen Energy, 2016. **41**(6): p. 3748-3761.
22. Schmidt, O., *Power-to-Gas Business Models in the United Kingdom*. Imperial College of London, 2013.
23. Kikkert, C.J., *The Effect of Power Renewables on the Grid in 20 Years Time*. The Institution of Engineering and Technology, 2016.
24. Welder, L., et al., *Spatio-Temporal Optimization of a Future Energy System for Power-to-Hydrogen Applications in Germany*. 2017.
25. FCH JU, *Commercialisation of Energy Storage in Europe*. FCH JU, March, 2015. **19**.
26. Franc, P.E., *Financing Hydrogen Projects*. 2012.
27. Dolci, F., et al., *Incentives and legal barriers for power-to-hydrogen pathways: An international snapshot*. International Journal of Hydrogen Energy, 2019. **44**(23): p. 11394-11401.
28. Ministère de la Transition Ecologique et Solidaire, *Plan de déploiement de l'hydrogène pour la transition énergétique*. 2018.
29. Philibert, C., *Renewable energy for industry*, IEA, Editor. 2017.
30. De Vita, A. and et al., *Sectoral integration - long-term perspective in the EU Energy System*, in *Final report of the ASSET project*. 2018.
31. Heuser, P., M. Robinius, and D. Stolten. *Techno-Economic Analysis of a Global Hydrogen Supply Chain based on Wind-Generated Hydrogen*. in *22nd World Hydrogen Energy Conference (WHEC 2018)*,. 2018. Rio de Janeiro, Brazil.
32. Padro, C.E.G. and V. Putsche, *Survey of the economics of hydrogen technologies*. 1999, National Renewable Energy Lab., Golden, CO (US).
33. Newton, J., *Power-to-Gas & Methanation - Pathways to a Hydrogen Economy*. 2014.
34. Scottish, E., *Hydrogen and Fuel Cell Opportunities for Scotland: The Hydrogen Energy Group Report*.
35. Australian Academy of S., *Towards development of an Australian scientific roadmap for the hydrogen economy*. 2008.
36. International Energy, A., *Hydrogen Production and Storage*. Hydrogen Implementing Agreement, 2006.
37. Royal Belgian Academy Council of Applied, S., *Hydrogen as an Energy Carrier*. 2006.
38. Strachan, N., et al., *State-of-the-art modelling on Hydrogen Infrastructure Development for the UK: Geographical, temporal and technological optimisation modelling*. Policy Studies Institute, 2008.
39. Ulf, B. and E. Baldur, *Energy and the Hydrogen Economy*. ABB Switzerland, 2010.
40. Iordache, I., A.V. Gheorghe, and M. Iordache, *Towards a hydrogen economy in Romania*. International Journal of Hydrogen Energy, 2013. **38**(28): p. 12231-12240.

41. Iordache, I., et al., *Hydrogen underground storage in Romania, potential directions of development, stakeholders and general aspects*. International Journal of Hydrogen Energy, 2014. **39**(21): p. 11071-11081.
42. de Joode, J., et al., *Exploring the role for power-to-gas in the future Dutch energy system*. ECN and DNV GL, Petten, The Netherlands, 2014.
43. Balan, O.M., et al., *Development of a technical and economic evaluation methodology for studying the implementation of Power-to-Gas in a specific case study* 2015.
44. Abbasi, T. and S.A. Abbasi, *'Renewable' hydrogen: Prospects and challenges*. Renewable and Sustainable Energy Reviews, 2011. **15**(6): p. 3034-3040.
45. Samsatli, S., I. Staffell, and N.J. Samsatli, *Optimal design and operation of integrated wind-hydrogen-electricity networks for decarbonising the domestic transport sector in Great Britain*. International Journal of Hydrogen Energy, 2016. **41**(1): p. 447-475.
46. Anders Bavnghøj, H., *Økonomisk/teknisk analyse af power-togas i energisystemet*. 2015.
47. Energinet, *Energikoncept 2030 – Sammenfatning T4 - En analyse af koncepter og udviklingsveje, der kan understøtte et konkurrencedygtigt og robust VE-baseret energisystem Y3 - 30.01.2019 M4 - Citavi*.
48. Reiter, G. and J. Lindorfer, *Global warming potential of hydrogen and methane production from renewable electricity via power-to-gas technology*. The International Journal of Life Cycle Assessment, 2015. **20**(4): p. 477-489.
49. Bennaceur, K., et al., *Hydrogen: A Future Energy Carrier?* Oilfield Review, 2005: p. 30-41.
50. R, G.M., *Hydrogen for Energy Storage*. 2014, Energy, Department of.
51. Dickinson, R., *From "fuel to power", to "power to fuel"*. 2016.
52. Fitzgibbons, K., *Future Prospects and Public Policy Implications for Hydrogen and Fuel Cell Technologies in Canada*. 2005.
53. Bloomberg New Energy, F., *Global Trends in Renewable Energy Investment 2015*. 2015.
54. Energy, U.S.D.o., *Hydrogen, Fuel Cells & Infrastructure Technologies Program*. 2007.
55. Lipman, T., *An overview of hydrogen production and storage systems with renewable hydrogen case studies*. Clean energy states Alliance, 2011.
56. Zhang, F. and P. Cooke, *The Green Vehicle Trend: Electric, Plug-in Hybrid or Hydrogen Fuel Cell*. 2009.
57. Bennoua, S., et al., *Role of hydrogen in resolving electricity grid issues*. International Journal of Hydrogen Energy, 2015. **40**(23): p. 7231-7245.
58. Pieper, C. and H. Rubel, *Revisiting Energy Storage: There Is a Business Case*. Boston Consulting Group, 2011.
59. Grond, L., P. Schulze, and J. Holstein, *Systems analyses power to gas*. DNV KEMA Energy & Sustainability, Groningen, 2013.
60. SBC Energy Institute, *HYDROGEN-BASED ENERGY CONVERSION*

More than storage: system flexibility. 2014.

61. Avril, S., et al., *Multi-objective optimization of batteries and hydrogen storage technologies for remote photovoltaic systems.* Energy, 2010. **35**(12): p. 5300-5308.
62. Agence de l'Environnement et de la Maitrise de l'Energie, A., *Étude sur le Potentiel du Stockage d'Energies.* 2013.
63. Agence de l'Environnement et de la Maitrise de l'Energie, A., *Etude portant sur l'hydrogène et la méthanation comme procédé de valorisation de l'électricité excédentaire.* 2014.
64. Mieog, J., R. Eenkhoorn, and J. Gigler, *Roadmap Power to Gas.* Royal HaskoningDHV, 2014.
65. Henning, H.M. and A. Palzer, *The role of power-to-gas in achieving Germany's climate policy targets with a special focus on concepts for road based mobility.* Fraunhofer Institute for Solar Energy Systems ISE. Freiburg, 2015.
66. Gahleitner, G., *Hydrogen from renewable electricity: An international review of power-to-gas pilot plants for stationary applications.* International Journal of Hydrogen Energy, 2013. **38**(5): p. 2039-2061.
67. Moran, P., et al., *Hydrogen energy and fuel cells. Strategic Roadmap.* 2011, Agence de l'Environnement et de la Maitrise de l'Energie-ADEME.
68. Etogas, *Power to Gas: Smart energy conversion and storage.* 2013.
69. Ecofys, *Energy Storage Opportunities and Challenges.* 2014.
70. Energy, U.S.D.o., *Grid Energy Storage.* 2013.
71. California Hydrogen Business, C., *Power-to-Gas: The Case for Hydrogen.* 2014.
72. Inage, S.-i., *Prospects for Large-Scale Energy Storage in Decarbonised Power Grids.* International Energy Agency, 2009.
73. Paul Denholm, J.J.M.H.T.J., et al., *The Value of Energy Storage for Grid Applications.* National Renewable Energy Laboratory, 2013.
74. Carnegie, R., et al., *Utility Scale Energy Storage Systems T4 - Benefits, Applications, and Technologies Y3 - 30.01.2019 M4 - Citavi.*
75. Reichert, F., *Wind-to-gas-to-money? Development and Planning.* Aalborg University, 2012.
76. Vandewalle, J., K. Bruninx, and W. D'Haeseleer, *Effects of large-scale power to gas conversion on the power, gas and carbon sectors and their interactions.* Energy Conversion and Management, 2015. **94**: p. 28-39.
77. Dickens, A., et al., *Energy storage: Power to the people.* London: HSBC Global Research, 2014.
78. M.W. Melaina, D.S., et al., *Hydrogen Infrastructure Market Readiness: Opportunities and Potential for Near-term Cost Reductions.* 2012.
79. Vandewalle, J., K. Bruninx, and W. D'Haeseleer, *The Interaction Of A High Renewable Energy/Low Carbon Power System With The Gas System Through Power To Gas.* The Working Paper - Energy and Environment, 2014.

80. Bünger, U., et al., *Power-to-gas (PtG) in transport status quo and perspectives for development*. German Federal Ministry of Transport and Digital Infrastructure, Tech. Rep, 2014. 6.
81. Hart, D., et al., *Scenarios for deployment of hydrogen in contributing to meeting carbon budgets and the 2050 target*. 2015.
82. Antonia, O. and G. Saur, *Wind to hydrogen in California: case study*. 2012, National Renewable Energy Laboratory (NREL), Golden, CO.
83. Moldrik, P. and Z. Hradilek, *Hydrogen Production for Solar Energy Storage*. Technical University of Ostrava, 2010. 17: p. s213-s215.
84. Stolzenburg, K., *Large Wind-Hydrogen Plants in Germany: The Potential for Success*. Results from the study "Integration von Wind-Wasserstoffsystemen in das Energiesystem". Berlin, 2013.
85. Schiebahn, S., et al., *Power to gas: Technological overview, systems analysis and economic assessment for a case study in Germany*. International Journal of Hydrogen Energy, 2015. 40(12): p. 4285-4294.
86. World Energy Council, *World Energy Resources E-storage: Shifting from cost to value Wind and solar applications 2016*: London, UK.
87. Carrasco, J.M., et al., *Power-Electronic Systems for the Grid Integration of Renewable Energy Sources: A Survey*. IEEE Transactions on Industrial Electronics, 2006. 53(4): p. 1002-1016.
88. Jensen, S.H., P.H. Larsen, and M. Mogensen, *Hydrogen and synthetic fuel production from renewable energy sources*. International Journal of Hydrogen Energy, 2007. 32(15): p. 3253-3257.
89. Sherif, S.A., F. Barbir, and T.N. Veziroglu, *Wind energy and the hydrogen economy - review of the technology*. Solar Energy, 2005. 78(5): p. 647-660.
90. Turner, J., et al., *Renewable hydrogen production*. International Journal of Energy Research, 2008. 32(5): p. 379-407.
91. Ursua, A., L.M. Gandia, and P. Sanchis, *Hydrogen production from water electrolysis: current status and future trends*. Proceedings of the IEEE, 2012. 100(2): p. 410-426.
92. Müller-Syring, G., et al., *Entwicklung von modularen Konzepten zur Erzeugung, Speicherung und Einspeisung von Wasserstoff und Methan ins Erdgasnetz*. 2013.
93. Fishedick, M., et al., *Synergieeffekte Gas-und Stromnetze*. 2015: Wuppertal Institut für Klima, Umwelt, Energie.
94. Graf, F., et al., *Abschlussbericht "Technoökonomische Studie von Power-to-Gas-Konzepten"*, Bonn, 2014. URL.
95. Moser, A., et al., *Nutzen von Smart-Grid-Konzepten unter Berücksichtigung der Power-to-Gas-Technologie*. Deutscher Verein des Gas-und Wasserfaches eV (DVGW), Bonn, 2014.
96. Hüttenrauch, J., et al., *Nutzen der Power-to-Gas-Technologie zur Entlastung der 110-kV-Stromverteilungsnetze*. Energie-, Wasser-Praxis.
97. ADEME, *Energy storage systems - Strategic Roadmap*. 2012.

98. Mahnke, E., J. Mühlhoff, and L. Lieblang, *Strom speichern*. Unendlich-viel-energie. de, 2014.
99. Sterner, M., et al., *Stromspeicher in der Energiewende*. Untersuchung zum Bedarf an neuen Stromspeichern in Deutschland für den Erzeugungsausgleich, Systemdienstleistungen und im Verteilnetz. Studie. Hg. v. Agora Energiewende. ef. Ruhr, 2014.
100. Alahuhta P, J.M.P.H., *Roadmap for Network Technology and Services*. TEKES, 2004.
101. Amer, M. and T.U. Daim, *Application of technology roadmaps for renewable energy sector*. Technological Forecasting and Social Change, 2010. **77**(8): p. 1355-1370.
102. Apak, S., E. Atay, and G. Tuncer, *Renewable hydrogen energy regulations, codes and standards: Challenges faced by an EU candidate country*. International Journal of Hydrogen Energy, 2012. **37**(7): p. 5481-5497.
103. Auer, J., *Germany's "Energiewende" driving Power-to-Gas*. Deutsche Bank Research, 2014.
104. Auer, J., *Moderne Stromspeicher - Unverzichtbare Bausteine der Energiewende*. Deutsche Bank Research, 2012.
105. Beccali, M., et al., *Method for size optimisation of large wind–hydrogen systems with high penetration on power grids*. Applied Energy, 2013. **102**: p. 534-544.
106. Bernard, P. and C. Musialski. *Electricity storage: EU policies and targets: which legal and regulatory framework?* . 2012. Luxembourg.
107. Sprinz, J., *Energy Smart Technologies - Hydrogen - Research Note*. Bloomberg New Energy Finance, 2014.
108. Boer, H., *The application of different types of large scale energy storage systems in the Dutch electricity system at different wind power penetration levels*. University of Groningen, 2012.
109. Bolat, P. and C. Thiel, *Hydrogen supply chain architecture for bottom-up energy systems models. Part 1: Developing pathways*. International Journal of Hydrogen Energy, 2014. **39**(17): p. 8881-8897.
110. Bolat, P. and C. Thiel, *Hydrogen supply chain architecture for bottom-up energy systems models. Part 2: Techno-economic inputs for hydrogen production pathways*. International Journal of Hydrogen Energy, 2014. **39**(17): p. 8898-8925.
111. Bundesministerium für Verkehr, B.u.S., *The Mobility and Fuels Strategy of the German Government (MFS)*. 2013.
112. Bundesnetzagentur für Elektrizität, G.T.P.u.E., *Monitoring Report 2013*. 2013.
113. Bünger, U., *Overview and Tentative Results of the HyUnder Project*. Fuel Cells and Hydrogen Joint Undertaking (FCH JU), 2014.
114. Kruck, O., et al., *Hyunder D3.1 - Overview on all Known Underground Storage Technologies for Hydrogen*. Fuel Cells and Hydrogen Joint Undertaking (FCH JU).
115. Slot, T. and P. van der Wijk, *Extended Flexibility Study – PtG potential in 2025 and 2030*. DNVGL T4 - Final Report Y3 - 31.01.2019 M4 - Citavi.
116. Ernst, et al., *Roadmap for the Realisation of a Wind Hydrogen Economy in the Lower Elbe Region*. 19.

117. Jechura, J., *Hydroprocessing: Hydrotreating and Hydrocracking*. Colorado School of Mines, 2014.
118. Power, I.T.M., *Hydrogen Energy Storage*. 2012.
119. Colvenaer, B., *Fuel Cells and Hydrogen Joint Undertaking*. Fuel Cells and Hydrogen Joint Undertaking (FCH JU) T4 - Current achievements and future ambitions Y3 - 31.01.2019 M4 - Citavi.
120. Hernandez-Santoyo, J. and A. Sanchez-Cifuentes, *DENA-Netzstudie, Integration erneuerbarer Energien in die deutsche Stromversorgung im Zeitraum 2015-2020 mit Ausblick 2025*. Deutsche Energie-Agentur GmbH, 2010.
121. Deutsche Energie, A., *Eckpunkte einer Roadmap Power to Gas*. 2013.
122. DENA, *Power to Gas: Eine innovative Systemlösung auf dem Weg zur Marktreife*. 2013: Berlin, Germany.
123. Deutsche Energie, A., *Efficient integration of renewable energy into future energy systems*. 2011.
124. Iskov, H. and N. Rasmussen, *Global screening of projects and technologies for Power-to-Gas and Bio-SNG*. Dansk Gasteknisk Center, 2013.
125. Judd, R. and D. Pinchbeck, *Power to Gas Research Roadmap*. Gas for Energy, 2013(2).
126. Technical University of D., *DTU International Energy Report 2013*. 2013.
127. Dubois, J., et al., *Safety cost of a large scale hydrogen system for photovoltaic energy regulation*. International Journal of Hydrogen Energy, 2013. **38**(19): p. 8108-8116.
128. Linke, G., *Power-to-Gas: Gas in an integrated energy system*. DVGW, EON, 2013.
129. Ease and Eera, *Joint EASE/EERA recommendations to the EC on a European Energy Storage Technology Development Road Map towards 2030*. 2013.
130. Geth, F., et al., *Energy Storage Innovation in Europe*. 2013.
131. The Electricity Storage, N., *Development of Electricity Storage in the National Interest*. 2013.
132. Lindorfer, J. and G. Gahleitner, *Alternative Fuels for Mobility and Transport: Harnessing Excess Electricity From Renewable Power Sources with Power-to-Gas*. 2013.
133. Electric Power Research, I., *Electric Energy Storage Technology Options: A White Paper Primer on Applications, Costs, and Benefits*. 2010.
134. Energy Research, P., *The future role for energy storage in the UK*. 2011.
135. Ertrac, *Energy Carriers for Powertrains*. 2014.
136. Garza, J., *Storage and Grid Balancing Opportunities in the UK and German Grids Under Future Renewable-Energy Penetration Scenarios*. EUREC Y3 - 31.01.2019 M4 - Citavi.
137. European Service, N., *Hydrogen energy and fuel cells*, in *EUR Community research*. 2003, Europäische Kommission: Luxembourg. p. 33.
138. Roland Berger Strategy, C., *FCH JU – Fuel Cell Distributed Generation Commercialisation Study*. Fuel Cells and Hydrogen Joint Undertaking (FCH JU), 2014.
139. FCH JU, *Urban Buses: Alternative Powertrains for Europe*. 2012.

140. Florisson, O. *Power-to-Gas: Supporting the accommodation of renewable electricity in European utility week October 2013*. 2013.
141. Mobilite, H.F.F., *H2 Mobilite France-Study for a Fuel Cell Electric Vehicle national deployment plan*. 2014.
142. FuelCellToday - The Leading Authority on Fuel, C., *Water Electrolysis & Renewable Energy Systems*. Fuel Cell Today, Royston, Hertfordshire (UK). <http://www.fuelcelltoday.com/analysis/surveys/2013/water-electrolysisrenewable-energy-systems>, 2013.
143. Gammer, D., *Clean Flexible Power using H2 Storage*. Energy Technologies Institute, 2014.
144. Oberhofer, A., *Energy Storage Technologies & Their Role in Renewable Integration*. GENI, 2012.
145. van der Weijde, G., *Power-to-Gas: A Promising Solution to Integrate Large Quantities of Fluctuating Renewable Power*. 2013.
146. Germany, T. and Invest, *Green Hydrogen and Power-to-Gas Technology*. 2012.
147. Carbon, T., *Polymer Fuel Cells – Cost reduction and market potential*. 2012.
148. Persson, T., et al., *A perspective on the potential role of biogas in smart energy grids*. 2014, Erscheinungsort nicht ermittelbar: IEA Bioenergy. 2137.
149. Iea, Etsap, and Irena, *Production of Bio-methanol - Technology Brief*. 2013.
150. Iec, *Electrical Energy Storage*. 2011.
151. Klell, M., H. Eichseder, and M. Sartory, *Mixtures of hydrogen and methane in the internal combustion engine – Synergies, potential and regulations*. International Journal of Hydrogen Energy, 2012. **37**(15): p. 11531-11540.
152. Vandewalle, J., *Natural gas in the energy transition*. KU Leuven, 2014.
153. Lampinen, A., *Roadmap to renewable methane economy*. Finnish Biogas Association and North Karelian Traffic Biogas Network Development Programme, 2012.
154. Lombardi, P., et al., *Power to Gas as an alternative energy storage solution to integrate a large amount of renewable energy: economic and technical analysis*. 2013.
155. BW, E.M., *Die Rolle von Wasserstoff in der Energiewende*. 2014.
156. Mansilla, C., et al., *Economic competitiveness of off-peak hydrogen production today - A European comparison*. Energy, 2013. **55**: p. 996-1001.
157. Caumon, P., et al., *Flexible hydrogen production implementation in the French power system: Expected impacts at the French and European levels*. Energy, 2015. **81**: p. 556-562.
158. Jentsch, M., T. Trost, and M. Sterner. *Evaluation of power-to-gas as long-term storage concept regarding electricity and CO2 sources*. in *6th International Renewable Energy Storage Conference-IREs 2011*. 2011.
159. McDowall, W., *Technology roadmaps for transition management: The case of hydrogen energy*. Technological Forecasting and Social Change, 2012. **79**(3): p. 530-542.
160. Müller-Syring, G., *Energiespeicherung in Erdgasnetzen*. DBI Gas- und Umwelttechnik GmbH, 2011.

161. Energy, A.E.A. and Environment, *Outlook of Energy Storage Technologies*. 2008.
162. Naturalhy, *Using the Existing Natural Gas System for Hydrogen*. 2009.
163. New Energy World, I.G., *Fuel Cell and Hydrogen Technologies in Europe*. 2011.
164. Wenzel, B. and J. Nitsch, *Langfristszenarien und Strategien für den Ausbau der Erneuerbaren Energien in Deutschland bei Berücksichtigung der Entwicklung in Europa und global*. 2010.
165. P. Denholm, E.E.B.K. and M.M. NREL, *The Role of Energy Storage with Renewable Electricity Generation*. National Renewable Energy Laboratory, 2010.
166. Roads2HyCom, F.C., *Hydrogen in a Sustainable Energy Economy*. Final Report of the Roads2HyCom Project, 2009.
167. Roads2HyCom, F.C., *Industrial surplus hydrogen and markets and production - Part II*. 2007.
168. Reese, M. and C. Marquart, *Lessons Learned in Developing a Wind to Ammonia Pilot Plant*. 2012.
169. deleeuw, c., *Fuel Cell Electric Buses – Potential for Decarbonising Public Transport in Europe*. Fuel Cells and Hydrogen Joint Undertaking (FCH JU), 2014.
170. laew Rwth Aachen University, P., *Analyse der Wirkung von Förderinstrumenten zur Marktintegration von Power to Gas in Deutschland*. 2013.
171. Saric, M., J.W. Dijkstra, and S. Walspurger, *Power-to-Gas coupling to biomethane production: a feasibility study*. ECN, 2013.
172. Schaber, K., F. Steinke, and T. Hamacher, *Managing Temporary Oversupply from Renewables Efficiently: Electricity Storage Versus Energy Sector Coupling in Germany*. 2013.
173. Schoots, K., et al., *Learning curves for hydrogen production technology: An assessment of observed cost reductions*. International Journal of Hydrogen Energy, 2008. **33**(11): p. 2630-2645.
174. Benjaminsson, G., J. Benjaminsson, and R.B. Rudberg, *Power-to-gas: a technical review*. 2013: Svenskt gastekniskt center.
175. Garmsiri, S., M. Rosen, and G. Smith, *Integration of Wind Energy, Hydrogen and Natural Gas Pipeline Systems to Meet Community and Transportation Energy Needs: A Parametric Study*. Sustainability, 2014. **6**(5): p. 2506-2526.
176. Smeets, F. and J. Vaes, *Electrolysis Systems for Grid Relieving*. 2014.
177. Smolinka, T., I. Energiesysteme, and W.E. Day, *Water electrolysis: status and potential for development*. Joint NOW GmbH-FCH JU Water Electrolysis Day April 3rd, 2014.
178. Lehner, M., et al., *Power-to-gas: technology and business models*. 2014: Springer.
179. Sachverständigenrat für, U., *Wege zur 100% erneuerbaren Stromversorgung*. 2011, Berlin: Erich Schmidt Verlag. 396 pages.
180. Energy Future, L., *Strategic Assessment of the Role and Value of Energy Storage Systems in the UK Low Carbon Energy Future*. Imperial College London, 2012.

181. Trost, T., M. Sterner, and M. Jentsch, *MOBILITY COSTS ANALYSIS AND LIFE CYCLE ASSESSMENT OF POWER-TO-GAS AS ALTERNATIVE FUEL*. 2011.
182. Low Carbon Innovation Coordination, G., *Technology Innovation Needs Assessment (TINA)*. 2014.
183. Velthuis, M., *The role of large scale energy storage systems in the electricity grid of the Netherlands in 2050*. 2012.
184. Weeda, M. and J. Joode, *The Potential of Power-to-Gas; the new Eureka?* ECN, 2013.
185. Weeda, M. and J. Joode, *Uitdagingen en oplossingen voor waterstof als optie voor lange termijn energieopslag*. ECN, 2014.
186. Wilson, D. *Power-to-Gas: Technology and Business Model Progress*. in *IPHE Workshop*. http://www.iphe.net/docs/Events/Seville_11-12/Workshop/Presentations/Session. 2012.
187. Schill, W.-P., *Residual Load, Renewable Surplus Generation and Storage Requirements in Germany*. SSRN Electronic Journal, 2013.
188. Robinus, M., *Strom- und Gasmarktdesign zur Versorgung des deutschen Straßenverkehrs mit Wasserstoff*. Forschungszentrum Jülich, IEK-3, 2016.
189. Varone, A. and M. Ferrari, *Power to liquid and power to gas: An option for the German Energiewende*. *Renewable and Sustainable Energy Reviews*, 2015. **45**: p. 207-218.
190. Otto, A., et al., *Closing the loop: captured CO₂ as a feedstock in the chemical industry*. *Energy & Environmental Science*, 2015. **8**(11): p. 3283-3297.
191. Gotz, M., et al., *Renewable Power-to-Gas: A technological and economic review*. *Renewable Energy*, 2015. **85**: p. 1371-1390.
192. BW, E.M., *Wasserstoff-Infrastruktur für eine nachhaltige Mobilität*. 2013.
193. Usdrive, *Hydrogen Delivery Technical Team Roadmap*. 2013.
194. Ramsden, T., D. Steward, and J. Zuboy, *Analyzing the levelized cost of centralized and distributed hydrogen production using the H2A production model, version 2*. 2009, National Renewable Energy Laboratory (NREL), Golden, CO.
195. Steward, D., T. Ramsden, and J. Zuboy, *H2A Production Model, Version 2 User Guide*. National Renewable Energy Laboratory, 2008.
196. André, J., et al., *Design and dimensioning of hydrogen transmission pipeline networks*. *European Journal of Operational Research*, 2013. **229**(1): p. 239-251.
197. Almansoori, A. and N. Shah, *Design and Operation of a Future Hydrogen Supply Chain*. *Chemical Engineering Research and Design*, 2006. **84**(6): p. 423-438.
198. Agnolucci, P., et al., *The importance of economies of scale, transport costs and demand patterns in optimising hydrogen fuelling infrastructure: An exploration with SHIPMod (Spatial hydrogen infrastructure planning model)*. *International Journal of Hydrogen Energy*, 2013. **38**(26): p. 11189-11201.

199. Strachan, N., et al., *Soft-linking energy systems and GIS models to investigate spatial hydrogen infrastructure development in a low-carbon UK energy system*. International Journal of Hydrogen Energy, 2009. **34**(2): p. 642-657.
200. Ingason, H., H. Pallingolfsson, and P. Jansson, *Optimizing site selection for hydrogen production in Iceland*. International Journal of Hydrogen Energy, 2008. **33**(14): p. 3632-3643.
201. Kamiya, S., M. Nishimura, and E. Harada, *Study on Introduction of CO₂ Free Energy to Japan with Liquid Hydrogen*. Physics Procedia, 2015. **67**: p. 11-19.
202. Noack, C., et al., *Studie über die Planung einer Demonstrationsanlage zur Wasserstoff-Kraftstoffgewinnung durch Elektrolyse mit Zwischenspeicherung in Salzkavernen unter Druck*. 2015.
203. Gerhardt, N., et al., *Interaktion EE-Strom, Wärme und Verkehr*. Endbericht. Fraunhofer IWES, 2015.
204. Trost, T., H. Höfling, and H. Jachmann, *Analyse von Power-to-Gas-Energiespeichern im regenerativen Energiesystem*. 2014, IWES, Fraunhofer: Kassel.
205. Tan-Ping, C., *Final Report - Hydrogen Delivery Infrastructure Options Analysis*. Nexant, 2010.
206. Stolzenburg, K., et al., *Integration von Wind-Wasserstoff-Systemen in das Energiesystem*. NOW-Studie, Berlin, 2013.
207. Ueckerdt, F., G. Luderer, and F. Müller-Hansen, *Analyse des Klimaschutzpotenzials der Nutzung von erneuerbarem Wasserstoff und Methan*. Abschlussbericht DVGW-Forschungsvorhaben, 2013.
208. Cazzola, P., et al., *Production Costs of Alternative Transportation Fuel*. International Energy Agency, 2013.
209. Hermann, H., L. Emele, and C. Loreck, *Prüfung der klimapolitischen Konsistenz und der Kosten von Methanisierungsstrategien*. Studie. Hg. v. Öko-Institut eV Berlin, 2014.
210. Pedersen, A.S., *Status and recommendations for RD&D on energy storage technologies in a Danish contest*. 2014.
211. Müller-Syring, G., et al., *Metastudie zur Untersuchung der Potenziale von Wasserstoff für die Integration von Verkehrs- und Energiewirtschaft*. 2017.
212. Estermann, T., M. Newborough, and M. Sterner, *Power-to-gas systems for absorbing excess solar power in electricity distribution networks*. International Journal of Hydrogen Energy, 2016. **41**(32): p. 13950-13959.
213. Scamman, D. and M. Newborough, *Using surplus nuclear power for hydrogen mobility and power-to-gas in France*. International Journal of Hydrogen Energy, 2016. **41**(24): p. 10080-10089.
214. Bergholcs, G., *Connecting Renewable Generation Sources*. ElectraNet, 2016.
215. Australian Energy Market, O., *Future Power System Security Program*. 2016.
216. Schoenung, S., *Commercial Potential For Renewable Hydrogen In California*. 2016.
217. Connolly, D., B.V. Mathiesen, and I. Ridjan, *A comparison between renewable transport fuels that can supplement or replace biofuels in a 100% renewable energy system*. Energy, 2014. **73**: p. 110-125.

218. Bhandari, R., C.A. Trudewind, and P. Zapp, *Life cycle assessment of hydrogen production via electrolysis – a review*. Journal of Cleaner Production, 2014. **85**: p. 151-163.
219. Budny, C., R. Madlener, and C. Hilgers, *Economic feasibility of pipe storage and underground reservoir storage options for power-to-gas load balancing*. Energy Conversion and Management, 2015. **102**: p. 258-266.
220. Clegg, S. and P. Mancarella, *Integrated Modeling and Assessment of the Operational Impact of Power-to-Gas (P2G) on Electrical and Gas Transmission Networks*. Ieee Transactions on Sustainable Energy, 2015. **6**(4): p. 1234-1244.
221. Steinmüller, H., R. Tichler, and G. Reiter, *Power-to-Gas– Eine Systemanalyse*. Energieinstitut an der Johannes Kepler Universität Linz, TU Wien, MU Leoben, JKU Linz, 2014.
222. Guandalini, G., S. Campanari, and M.C. Romano, *Comparison of Gas Turbines and Power-to-Gas Plants for Improved Wind Park Energy Dispatchability*. Proceedings of the Asme Turbo Expo: Turbine Technical Conference and Exposition, 2014, Vol 3a, 2014.
223. Klumpp, F., *Potential for large scale energy storage technologies - comparison and ranking including an outlook to 2030*. Energy Proced (9th International Renewable Energy Storage Conference, Ires 2015), 2015. **73**: p. 124-135.
224. Kroniger, D. and R. Madlener, *Hydrogen storage for wind parks: A real options evaluation for an optimal investment in more flexibility*. Applied Energy, 2014. **136**: p. 931-946.
225. Palzer, A. and H.M. Henning, *A comprehensive model for the German electricity and heat sector in a future energy system with a dominant contribution from renewable energy technologies - Part II: Results*. Renewable & Sustainable Energy Reviews, 2014. **30**: p. 1019-1034.
226. Qadrdan, M., et al., *Role of power-to-gas in an integrated gas and electricity system in Great Britain*. International Journal of Hydrogen Energy, 2015. **40**(17): p. 5763-5775.
227. Schaber, K., *Integration of Variable Renewable Energies in the European power system: a model-based analysis of transmission grid extensions and energy sector coupling*. 2014, Universitätsbibliothek der TU München.
228. Vartiainen, V., *Screening of Power to Gas Projects*. Lappeenranta University of Technology T4 - Master's Thesis Y3 - 31.01.2019 M4 - Citavi.
229. Tractebel and Hincio, *STUDY ON EARLY BUSINESS CASES FOR H2 IN ENERGY STORAGE AND MORE BROADLY POWER TO H2 APPLICATIONS*. 2017.
230. Eichman, J., A. Townsend, and M. Melaina, *Economic Assessment of Hydrogen Technologies Participating in California Electricity Markets*. 2016, NREL (National Renewable Energy Laboratory (NREL), Golden, CO (United States)).
231. Eichman, J. and F. Flores-Espino, *California Power-to-Gas and Power-to-Hydrogen Near-Term Business Case Evaluation*. 2016, NREL (National Renewable Energy Laboratory (NREL), Golden, CO (United States)).

232. Reuß, M., et al., *Seasonal storage and alternative carriers: A flexible hydrogen supply chain model*. Applied Energy, 2017. **200**: p. 290-302.
233. Otto, A., et al., *Power-to-Steel: Reducing CO₂ through the Integration of Renewable Energy and Hydrogen into the German Steel Industry*. Energies, 2017. **10**(4): p. 451.
234. Robinius, M., et al., *Linking the Power and Transport Sectors-Part 2: Modelling a Sector Coupling Scenario for Germany*. Energies, 2017. **10**(7): p. 957.

Part 2: Task Force Electrolyser Data

State-of-the art CAPEX data for water electrolyzers, and their impact on renewable hydrogen price settings

Author: Joris Proost

Affiliation: Université catholique de Louvain, Louvain-la-Neuve, Belgium

Abstract

Within this framework, a specific task force was set-up for the compilation of state-of-the-art technical and economical data on large-scale water electrolyser systems, both based on PEM and alkaline technology. The objectives set forward have been twofold. Firstly, to offer policy makers and industry with comprehensive trends and guidelines for further electrolyser cost reduction (CAPEX, in Euro/kW) into the MW-scale. Secondly, to provide objective technological & economic arguments for converging towards a realistic electrolytic (and hence renewable) H₂ market price (in Euro/kg). This should help water electrolysis to become competitive with SMR technology for (local) H₂ production, and hence to start making H₂ a competitive fuel.

Keywords

- Electrolyser
- CAPEX
- H₂ price
- Alkaline
- PEM

Introduction

Hydrogen is currently considered to be one of the key enabling technologies allowing future large-scale and long-term storage of renewable electricity production through the now well-established Power-to-Gas concept [1], [2]. Such chemical storage is based on the direct electrochemical splitting of water into hydrogen and oxygen ($2\text{H}_2\text{O} = 2\text{H}_2 + \text{O}_2$), using renewable electricity to power the water electrolyser system. A number of encouraging reports have recently been published on the technological and economical viability of the P2G concept, based on running or past large-scale demonstration projects, especially in Europa [3], [4], [5]. Independent of its recognised potential for storage purposes of electricity "upstream", there is still a vast range of opportunities to be explored "downstream" with respect to the use of such electrolytic (and hence renewable) H_2 . Indeed, with the different rather ambitious roll-out scenarios for renewable electricity worldwide by 2020 and beyond, a vast amount of "green and clean" H_2 can be expected to become available on the market on a relatively short term [6], [7]. For this very reason, water electrolysis is currently being considered as well to be the only viable route towards large-scale CO_2 -free H_2 production. In this respect, it can be expected at some point in time to become competitive with steam methane reforming (SMR). The latter is still the main H_2 production technology used today, but intrinsically suffers from significant CO_2 emissions ($\text{CH}_4 + 2\text{H}_2\text{O} = 4\text{H}_2 + \text{CO}_2$). In order for such a technological revolution to become feasible, the investment cost of industrial water electrolysers (CAPEX, in Euro/kW) first needs to become sufficiently low in order to guarantee the electrolytic H_2 production cost (in Euro/kg), to become competitive to SMR H_2 .

One of the first relevant studies in this respect is the industry technical report by Stoll and van Linde, originally published in 2000 in Hydrocarbon Processing Magazine [8]. The authors provided a number of cost comparisons amongst the 3 main production technologies for providing H_2 in sufficiently large quantities (50–4000 Nm^3/hr): water electrolysis, steam reforming and methanol cracking. In their estimations, they included both capital investments (CAPEX), but also primary energy requirements and operational expenses (OPEX), like depreciation and interest on capital investment, utilities and feedstock costs, manpower and maintenance. Although this report might have become a bit dated as of today, especially in terms of the projected investment cost for large-scale electrolysers, it does have the generic merit of pointing out the relative importance of operational costs. For instance, based on the numbers relevant for the year 2000, it appeared that in only one year, the difference in production costs of the different H_2 technologies can in some cases exceed the total investment cost. In our current paper, essentially because of the lack of reliable OPEX data on operating large-scale electrolysers, we will only concentrate on their CAPEX. Moreover, the projected production cost of electrolytic H_2 today is dominated by the cost of electricity [9], which can therefore still be considered to be the dominant OPEX parameter.

Rather recently, literature studies have been dedicated to summarize both historical trends [10] and short- and long-term projections [11] of investment cost (CAPEX) and performance data for two of the most common water electrolysers technologies being used today, namely alkaline and Proton Exchange Membrane (PEM) systems. However, such literature reports are often only able to generate a relative

wide range of CAPEX data, depending on the exact performance (e.g. input power) of the system being considered. For instance, Fig. 1 summarizes CAPEX data from the available literature reports reviewed in Ref. [10]. It can be observed that the spread of the CAPEX estimations in the 1990s was in the range 870–2350 Euro/kW and 310–4750 Euro/kW for alkaline and PEM technology, respectively. At the same time, estimations for the future investment costs by the year 2030 are reported to be in the range 790–910 Euro/kW and 400–960 Euro/kW, respectively.

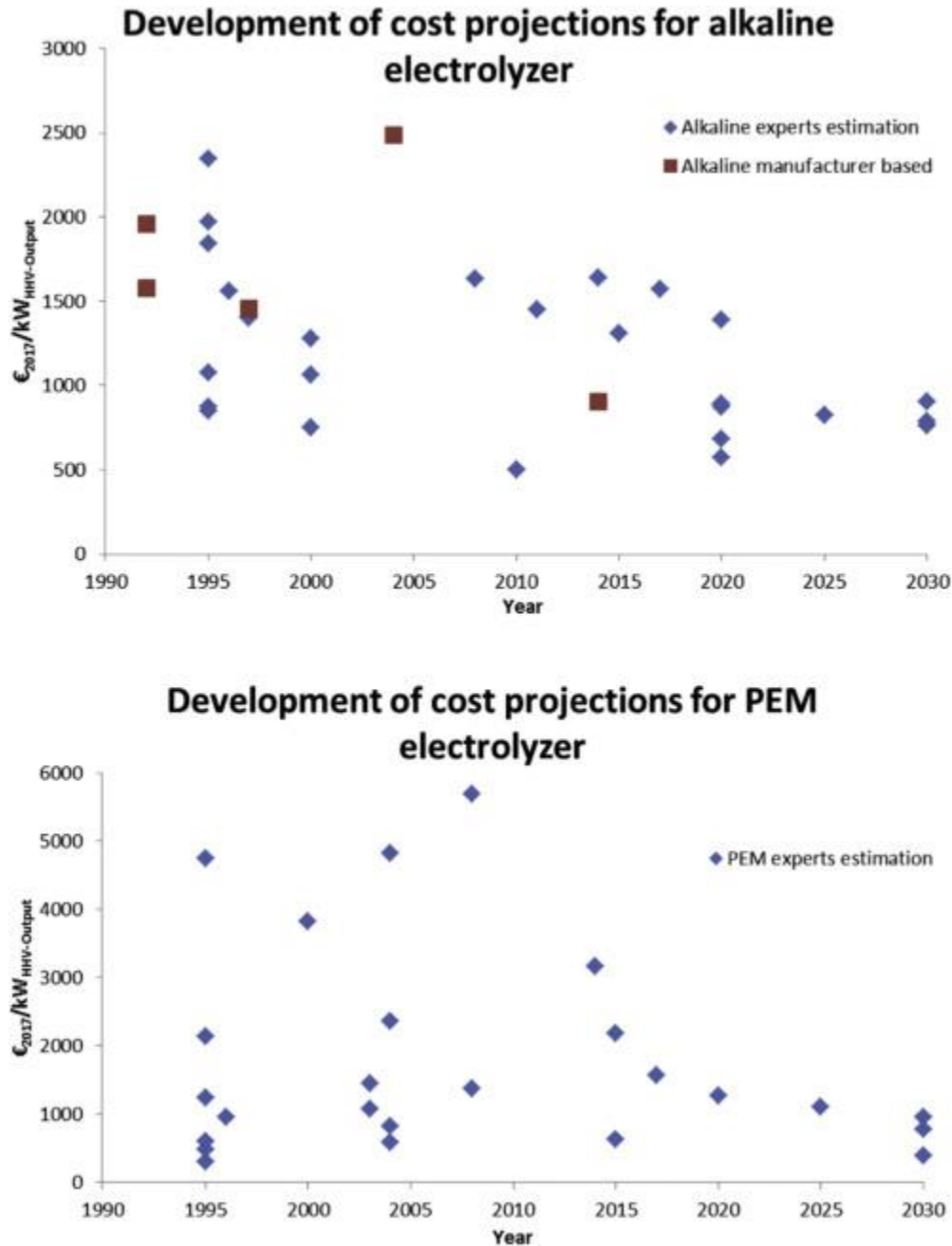

Fig. 1. Compilation of past and expected alkaline (top) and PEM (bottom) electrolysis plant cost in Euro/kW, based on available literature studies (reproduced from Ref. [10]).

When it comes to the short- and long-term projections reported in the expert elicitation study on future cost and performance of water electrolyzers of ref. [11], capital costs by 2020 are predicted to lie between 800 and 1300 Euro/kW for alkaline, and between 1000 and 1950 Euro/kW for PEM systems (all 50th percentile estimates, at current R&D funding and without production scale-up). By 2030, these costs are estimated in the same report to be only slightly lower than in 2020, being in the range 700–1000 Euro/kW and 850–1650 Euro for alkaline and PEM, respectively.

Although such ranges can be useful to have a first qualitative idea of cost orders and projected improvements, much more concise CAPEX values for electrolyser systems are needed for a more quantitative modeling of specific business case studies, especially when it comes down to predicting a realistic electrolytic H₂ production cost. Therefore, there is still an emerging need for "real-life" cost data coming from the electrolyser manufacturers themselves, based on actual electrolyser systems already on the market today. For this very reason, within the Hydrogen Implementing Agreement (HIA) of the International Energy Agency (IEA), a new Task 38 was set-up early 2016, entitled "Power-to-Hydrogen and Hydrogen-to-X: System Analysis of the techno-economic, legal and regulatory conditions". In particular, a specific task force was asked to collect techno-economical data on commercially available water electrolyser systems directly from the major electrolyser manufactures involved in the Task 38 effort.

Results & discussion

Comparing CAPEX for electrolytic and SMR H₂ production systems:

As a starting point, Fig. 2 (re-)considers published data [12], [13] already available from the previous IEA/HIA Task 33 on Local hydrogen production for energy applications (2013–2015), this task being itself a continuation of both Task 23 on Small scale reformers for on-site hydrogen supply (2006–2011) and Annex 16 Subtask C on Small stationary reformers for distributed hydrogen production (2002–2005). Fig. 2 shows the actual CAPEX evolution of PEM electrolyser systems, both as a function of H₂ production capacity (in Nm³/hr, Fig. 2a) and as a function of the equivalent electrolyser power input (in kW, Fig. 2b). The latter graph was derived from the first one, based on data collected separately from the PEM electrolyser manufacturers on the specific electrical energy consumption (in kWh/Nm³ H₂) in the range 7–700 kW. Note that the latter refers to the overall energy consumption of the hydrogen plant, including electrolyser, transformer and all auxiliaries (like rectifier losses). These additional data are

shown in Fig. 2 c as well, the linear fit resulting in a conversion factor of $5.2 \pm 0.1 \text{ kWh/Nm}^3 \text{ H}_2$, in agreement with published state-of-the-art values for PEM electrolyzers [1].

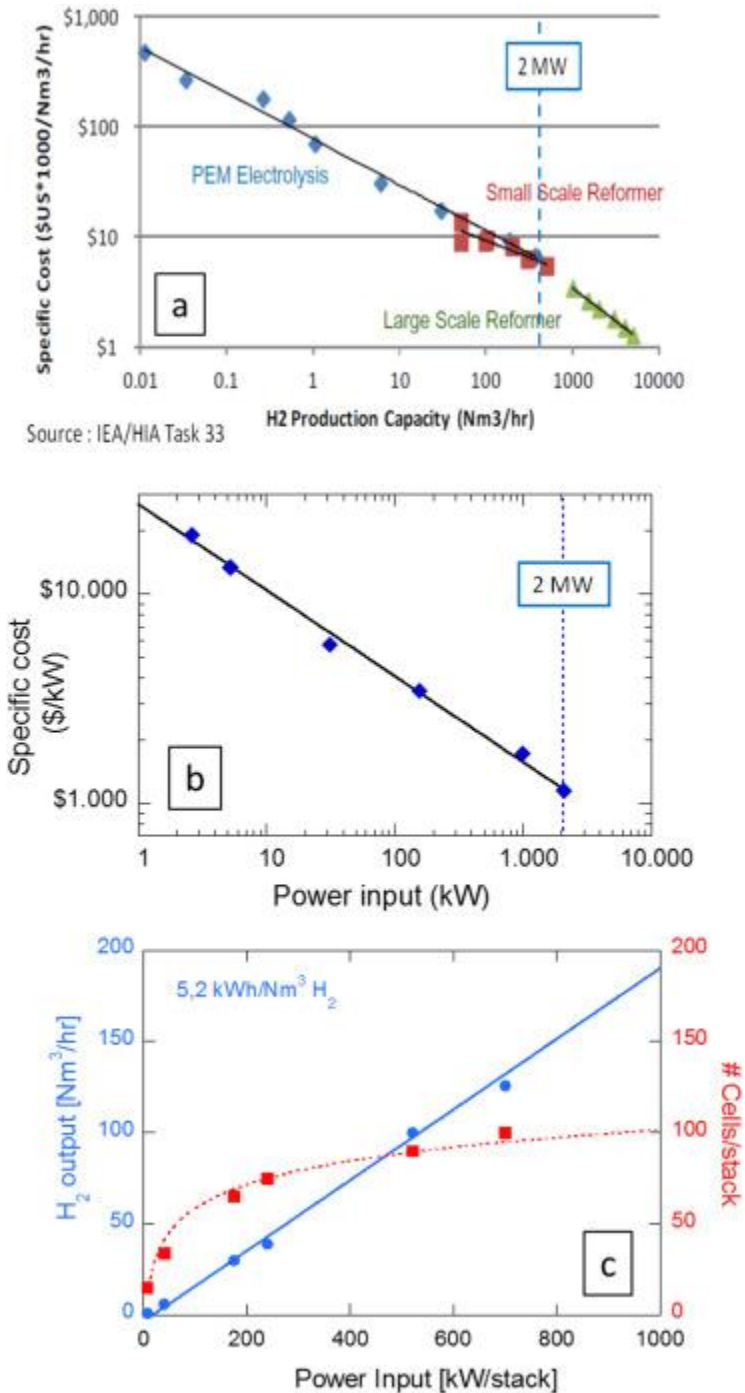

Fig. 2. CAPEX data for PEM electrolyzers, collected from Task 33 [12], [13], as a function of H₂ production capacity (a) and replotted as a function of equivalent power input (b). The conversion factor corresponds

to a specific electrical energy consumption of 5.2 kWh/Nm³ (c). The latter figure also represents the number of cells/stack needed to comply with a given input power in the range 7–700 kW.

With respect to the first graph (Fig. 2a), its great merit lies in the fact that it also includes data collected for both small and large scale SMR systems, which is the main H₂ production technology used today. Based on these data, it can already be recognised that in order for water electrolysis to become a viable technological choice for H₂ production, independent of any storage applications, a process intensification into the MW-range is absolutely mandatory. As a matter of fact, this is not only a necessary condition to become competitive in terms of CAPEX to SMR H₂ production technology, but also an inherent prerequisite to be able to couple to the MW-scale renewable electricity production capacities, typical for e.g. today's on-shore wind mills. Moreover, such a coupling to renewables is also an absolute complementary boundary condition for any water electrolyser technology to be able to produce truly green and clean H₂.

With respect to this need for a process intensification into the MW-scale, Fig. 2 c also includes additional data on the number of cells/stack needed to comply with a given electrical input. From the collected PEM data for PEM systems, it seems that 100 cells/stack represents some kind of intrinsic upper limit, corresponding to a 1 MW PEM system. Therefore, for Power-to-Gas applications in the multi-MW range, an electrolyser system based on multiple PEM stacks would be required. Such a shift from single to multi-stack systems has so far generally been neglected in the literature when it comes to future CAPEX projections, although it significantly affects the expected decreasing trendline of CAPEX vs. power input, as will be discussed below.

Comparing CAPEX for PEM and alkaline electrolysers

An attempt was then made to complement the previous compilation effort on PEM data from Task 33 with CAPEX data for alkaline water electrolysers. The latter are today still considered to be the most mature and durable technology, especially for large-scale and long-term renewable H₂ production [14]. Such a comparison of CAPEX data for both PEM and alkaline electrolysers is shown in Fig. 3, again as a function of the overall energy consumption of the hydrogen plant. The latter was explicitly verified with the electrolyser manufacturers to include the following components:

- Transformer(s), rectifier(s), control panel with PLC;
- Water demineralizer/deionizer;
- Electrolyser stack(s);
- Gas analysers, separators and separating vessels;
- Scrubber or gas purifier system & recirculating pump;
- Dry piston compressor @ 15 bar (note that PEM systems are typically self-pressurising upto

20/50 bar).

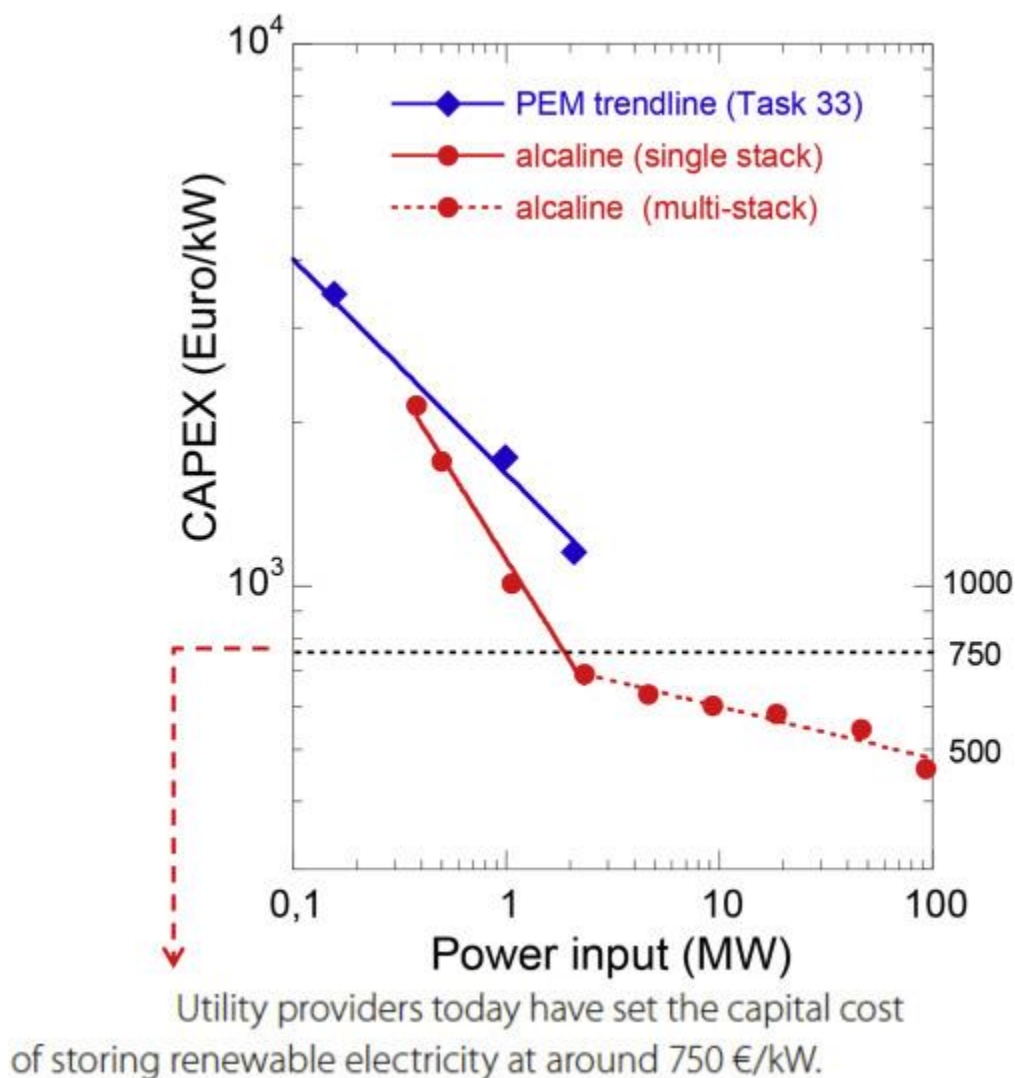

Fig. 3. CAPEX data for both PEM and alkaline electrolyzers, plotted as a function of power input. Data for alkaline systems are based on a single stack of 2.13 MW consisting of 230 cells, 2.6 m² in size. The change in slope for alkaline electrolyzers corresponds to the use of multi-stack systems.

For the alkaline data, an overall energy consumption of 4.8 kWh/Nm³ was considered in Fig. 3, as specified directly by the manufacturer. Based on a H₂ Higher Heating Value (HHV) of 3.54 kWh/Nm³, this corresponds to an efficiency of 80% for the electrolyser itself (4.4 kW/Nm³, DC power), while the overall system would be running at 74% efficiency (at the specified discharge pressure level of 15 bar).

Fig. 3 clearly demonstrates that, for single stack systems, alkaline electrolyzers are much more susceptible to CAPEX reduction upon scaling than PEM. In particular, for alkaline systems, a CAPEX of 750 Euro/kW,

considered by utility providers to be the capital cost for storing renewable electricity, is already realistic today for a single stack 2 MW system. For PEM, such a critical CAPEX value should become within reach for 5 MW systems, requiring the use of multi-stack systems.

With respect to the latter, Fig. 4 gives some perspectives for further CAPEX reduction upon the use of multi-stack systems, both for PEM (a) and alkaline (b) electrolyzers. It can be seen that contrary to single-stack systems, such a further reduction in CAPEX upon scaling is much more pronounced (on a relative scale) for a multi-stack PEM design than for alkaline. On the other hand, it should be noted that in the above CAPEX estimations, life cycle issues of electrolyzers and electrodes have not been taken into account. Clearly, with the durability aspect of alkaline stacks currently still very much in favor in current state-of-the-art alkaline vs. PEM technologies, including such lifetime (and hence OPEX) aspects in the calculation can be expected to somewhat flatten out the projected difference in CAPEX reduction between alkaline and PEM for multi-stack systems.

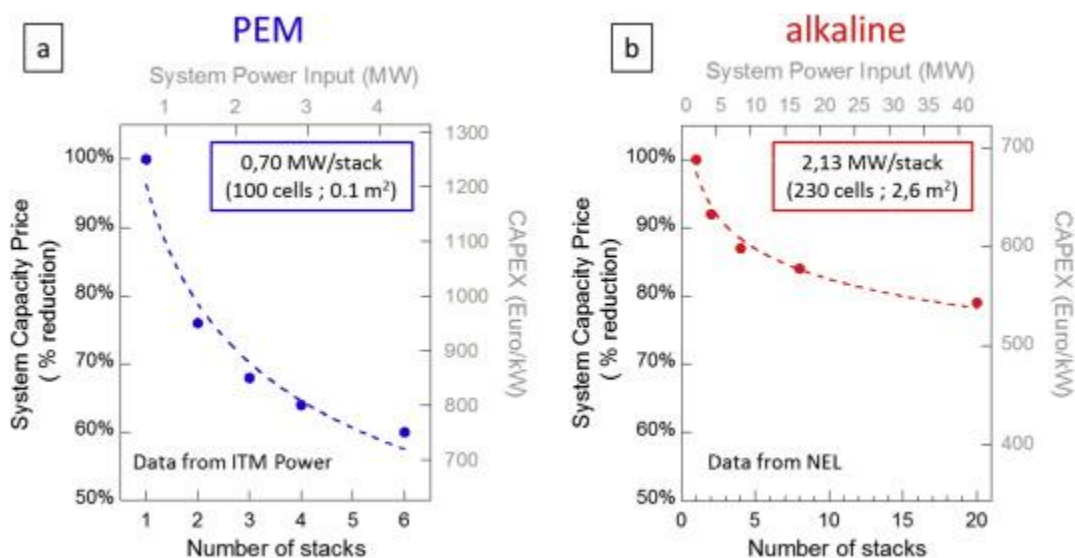

Fig. 4. Reduction in CAPEX upon use of multi-stack systems, both for PEM (a) and alkaline (b) electrolyzers.

Moreover, in absolute terms, CAPEX values as low as 400 Euro/kW are currently projected by NEL for alkaline systems when scaling up to 100 MW. The latter is based on an intelligent engineering design of a 40-stack system. Moreover, the manufacturer also claims that it would be very feasible to deliver hydrogen at 100 bar for more or less the same CAPEX value as the hydrogen pressure of 15 bar considered as default for alkaline systems in Fig. 3, Fig. 4. This would significantly improve their Power-to-Gas and energy storage business cases, where high pressures are indeed required.

Impact of CAPEX on electrolytic H₂ price settings

Apart from the intrinsic quantitative merit of the above alkaline and PEM electrolyser CAPEX data as such, a major additional asset is that they also allow for a better fine-tuning of projections and simulations regarding price settings for electrolytic (i.e. renewable) H₂. In this respect, some simulations from the literature have been reproduced from Ref. [15] in Table 1, representing a number of relevant production scenario's. This Table, dating back from 2015 and therefore overestimating current available CAPEX values, can still be taken as a useful relative starting point to identify the main additional operational parameters for setting a realistic H₂ price. These include, besides electrolyser CAPEX, also electrolyser efficiency, annual operating hours and (renewable) electricity cost. Despite the discrete character of the simulations, and the lack of elementary definitions and explanations in Ref. [15], some general relative trends can still be distinguished from the at first sight rather arbitrary parameter combinations. First of all, considering scenario's 5 and 2, it appears that, at a fixed (overestimated) CAPEX of 800 Euro/kW and for a renewable electricity cost on the order of 60–70 Euro/MWh, an electrolytic H₂ production cost on the order of 4 Euro/kg is obtained. However, this still requires that the electrolyser can be kept operational for a sufficient amount of time (assumed 7000/8760 \cong 80% on a yearly basis in scenario 5), which seems as of today not very feasible in view of the relatively weak penetration of H₂ for P2G storage purposes. When the electrolyser "up-time" further decreases to 20% (or 2000 hrs/year, cfr. scenario 2), the electrolytic H₂ production cost goes up to about 6 Euro/kg. This is clearly not sufficiently competitive, except maybe for H₂ mobility applications [16]. Moreover, if at about the same conditions as scenario 2 the electricity price would double to 140 Euro/MWh (cfr. scenario 3), the electrolytic H₂ production cost reaches totally unacceptable levels of more than 12 Euro/kg. It appears that in this range of relatively low operational time (<2000 hrs/year), even a zero renewable electricity cost would still result in unacceptable H₂ prices > 10 Euro/kg (cfr. scenario 4).

Table 1. Electrolytic H₂ production cost according to various scenario's (reproduced from Ref. [15]).

Scenario	1	2	3	4	5
CAPEX electrolyser (Euro/kW)	2000	800	800	800	800
Efficiency electrolyser (%)	60	80	80	80	80
Annual operating hours (1 year = 8760 h)	7000	2000	1000	500	7000
Renewable electricity cost (Euro/MWh)	70	70	140	0	60

Scenario	1	2	3	4	5
Electrolytic H ₂ production cost (Euro/kg)	7.0	6.1	12.2	10.5	3.7

From Table 1, it is obvious that the expected annual operating hours clearly is a critical parameter to consider for electrolytic H₂ cost projections. Therefore, it makes much more sense to represent its effect on a continuous rather than a discrete scale. Recent examples from the literature are given in Fig. 5 [17], [18] and Fig. 6 [19] for different CAPEX and renewable electricity prices, respectively. For these simulations, the electrolyser efficiency was kept constant at about 70–80%, which appears to be the limiting value that is being accepted for future electrolyser generations as well [11]. As to the effect of electrolyser CAPEX, both Fig. 5 a [17] and Fig. 5 b [18] quantitatively confirm one of the major conclusions from Table 1, namely that for an insufficient electrolyser up-time (<2000 hrs/year), the cost of electrolytic H₂ increases very steeply. Moreover, for an assumed renewable electricity price of 70 Euro/MWh, Fig. 5 a and Table 1 also appear to be quantitatively coherent in terms of H₂ price for a CAPEX of 2000 Euro/kW (scenario 1) and 1000 Euro/kW (scenario 2), respectively. In Fig. 5 b, reproduced from a more recent study [18], a further refinement of price simulations is provided for CAPEX values closer to today's technological reality. This particular study also takes into account more refined assumptions for the (average) electricity price, based on so-called power price duration curves. The latter have been included between brackets under the CAPEX values corresponding to the different curves. These results indicate that, already at current CAPEX values of 700 Euro/kW (considered to be realistic as of today for a 2 MW alkaline electrolyser, cfr. Fig. 3), an electrolytic H₂ production cost below 4 Euro/kg can be obtained once an electrolyser uptime >20% can be guaranteed. Moreover, this cost further decreases to 3 Euro/kg upon a further decrease in CAPEX towards 400 Euro/kW.

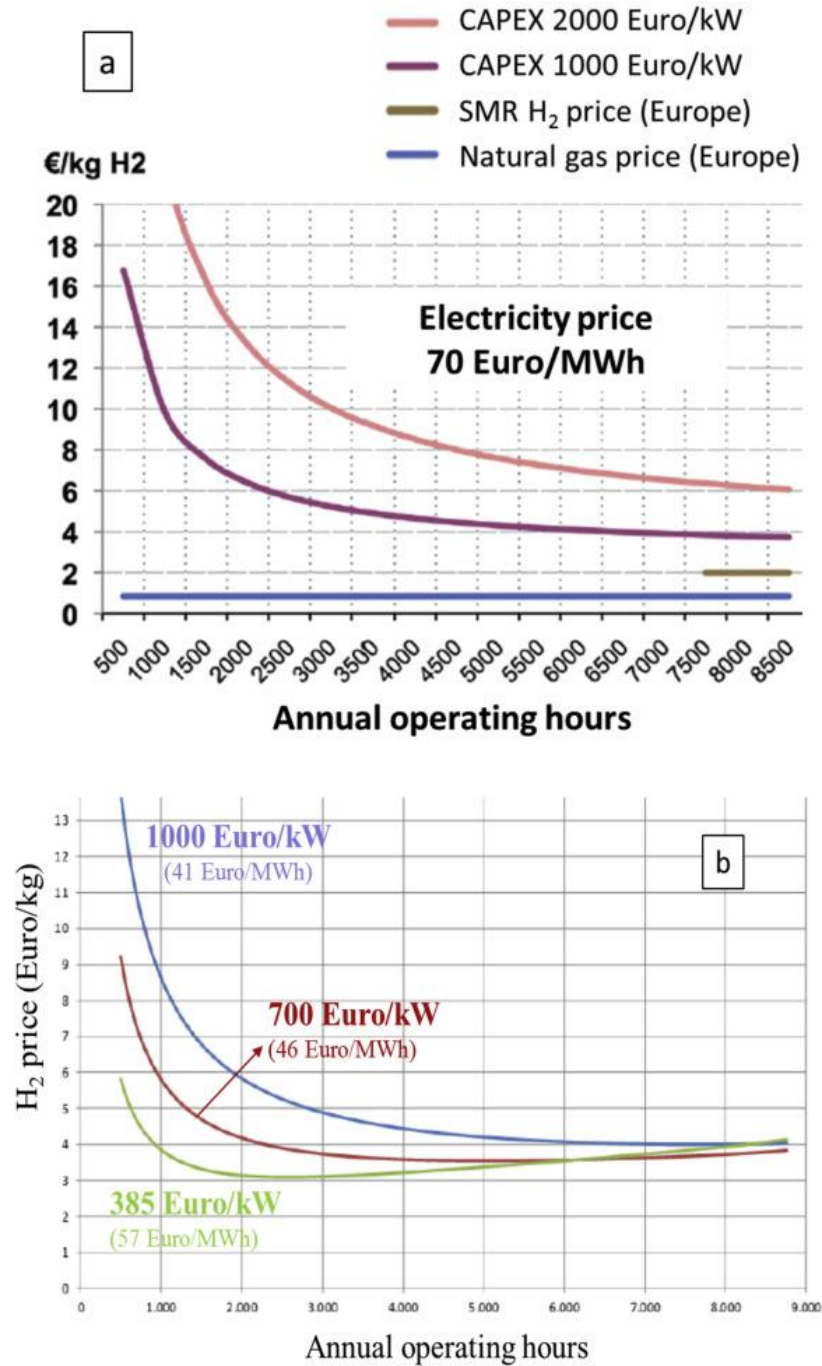

Fig. 5. Electrolytic H₂ production cost (in Euro/kg) as a function of electrolyser operational time for different electrolyser CAPEX values; figures (a) and (b) are reproduced from Ref. [17] and ref. [18], respectively.

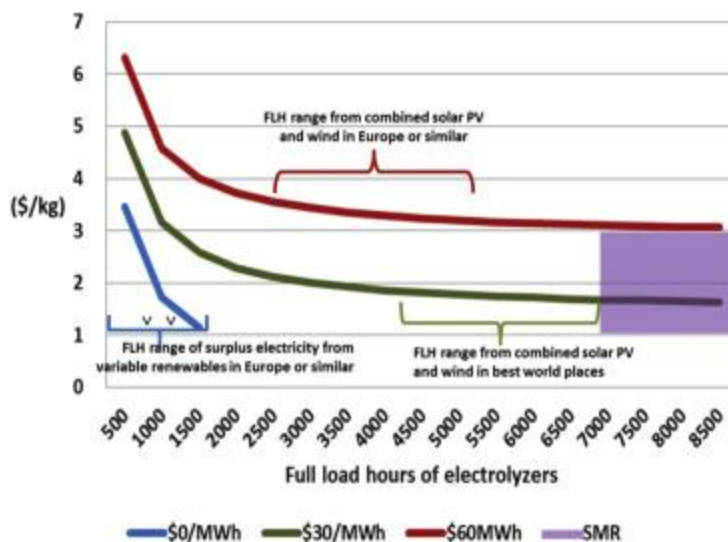

Fig. 6. Electrolytic H₂ production cost (in USD/kg) as a function of electrolyser operational time (FLH = full load hours) for different renewable electricity costs (in USD/MWh), reproduced from Ref. [19]. Further assumptions are an electrolyser CAPEX of 450 USD/kW, a lifetime 30 years, and a system efficiency of 70%. The cost of hydrogen from SMR (purple area) was estimated at 1–3 USD/kg, depending on regional variations in natural gas prices. (For interpretation of the references to color in this figure legend, the reader is referred to the Web version of this article.)

Finally, results from a relatively recent IEA study [19], reproduced in Fig. 6, allow to anticipate a further evolution in H₂ production cost as a function of the available renewable electricity price, assuming the most favorable (but still realistic) CAPEX value of 450 USD/kW. Note that in Ref. [19] the default currency was USD, which still entails some uncertainty when comparing to the above CAPEX or H₂ prices expressed in Euro's. Three different cases have been considered. Firstly, in countries with good but not excellent solar and wind resources, the cost of electricity can be assumed to be about USD 60 per MWh (cfr. red line in Fig. 6). For this combination of onshore wind power and solar PV electricity, the associated load factor will hardly be above 4500 full load hours (FLH), which brings the average electrolytic H₂ production cost to 3–4 USD/kg.

Secondly, at times of excess electricity production from renewables, the market price of electricity can become very low. Assuming a zero renewable electricity price (cfr. blue line in Fig. 6), it can be seen that the cost of electrolytic hydrogen becomes very dependent on the electrolyser load factor. For instance, if the relevant load factor which may take benefit from such free ("dumped") electricity is in the range of 1000 FLH, electrolytic hydrogen can still become very competitive, at a production cost of less than 2 USD/kg. However, since such small load factors generally also entail a smaller scale electrolyser, its CAPEX will be significantly higher than the 450 USD/kW assumed in Fig. 6. In that case, as already shown in Table 1 (cfr. scenario 4), load factor uncertainties can make such an investment quite risky.

Thirdly, a combination of high load factors and a non-zero but relatively low electricity cost, on the order of 30 USD/MWh (cfr. green line in Fig. 6), would allow electrolytic H₂ production costs to compete with SMR. In this case, both the cost of renewables and the relevant load factors essentially depend upon the quality of the solar and wind resources. Alternatively, as suggested in Ref. [19], areas with abundant hydropower and/or geothermal resources would also be possible choices for siting large-scale electrolyzers.

In conclusion, based on all of the above simulations and taking into account our own compiled CAPEX values of Fig. 3, Fig. 4, it appears that an electrolytic H₂ production cost on the order of 3–4 Euro/kg is very realistic by 2020, the lower and upper bound limit mainly depending on the best available renewable electricity price. This is very much comparable to SMR H₂. As to the latter, it should be noted though that, for a fair comparison, OPEX costs should eventually be taken into account as well, as already pointed out in Ref. [8] (e.g. not only electricity price for electrolytic H₂, and an additional CO₂ tax for SMR). Nonetheless, we believe that these preliminary projections should on the one hand stimulate a further, large-scale penetration of H₂ technologies for renewable energy storage purposes. On the other hand, it should also provide confidence for the ultimate consideration of electrolytic H₂ as a basic chemical building block, enabling direct coupling to renewable electricity production and hence helping to green the materials and fuels industry.

Conclusions

At this stage of the IEA/HIA Task 38 effort, the following major conclusions have been reached:

- for alkaline systems, a CAPEX of 750 Euro/kW, considered to be critical for storage purposes, is already realistic today for a single stack, 2 MW system;
- for PEM, such CAPEX values come within reach for 5 MW systems, requiring multi-stack systems;
- CAPEX values on the order of 400 Euro/kW have been projected for alkaline systems, but this will require further upscaling upto 100 MW;
- from the state-of-the-art CAPEX data collected, an electrolytic H₂ production cost on the order of 3 Euro/kg is very realistic by 2020, very much comparable to SMR H₂.

Acknowledgements

Participation of JP to the IEA/HIA Task 38 and the IEA/HIA ExCo is supported by the Public Service of Wallonia – Dept. of Energy and Sustainable Building. We would also like to cordially thank Eric Dabe from NEL and Lucas Bertrand and Marcus Newborough from ITM Power for sharing their CAPEX data within the Task 38 effort.

REFERENCES

- [1] Butler A, Spliethoff H. Current status of water electrolysis for renergy storage, grid balancing and sector coupling via power-to-gas and power-to-liquids: a review. *Renew Sustain Energy Rev* 2018;82:2440e54.
- [2] Götz M, Lefebvre J, Mörs F, McDaniel Koch A, Graf F, Bajohr S, et al. Renewable Power-to-Gas: a technological and economic review. *Renew Energy* 2016;85:1371e90.
- [3] Kopp M, Coleman D, Stiller C, Scheffer K, Aichinger J, Scheppat B. Energiepark Mainz: technical and economic analysis of the worldwide largest Power-to-Gas plant with PEM electrolysis. *Int J Hydrogen Energy* 2017;42:13311e20.
- [4] Guandalini G, Robinius M, Grube T, Campanari S, Stolten D. Long-term power-to-gas potential from wind and solar power: a country analysis for Italy. *Int J Hydrogen Energy* 2017;42:13389e406.
- [5] Caumon P P, Zulueta ML-B, Louyrette J, Albou S, Bourasseau C, Mansilla C. Flexible hydrogen production implementation in the French power system: expected impacts at the French and European levels. *Energy* 2015;81:556e62.
- [6] Walker SB, van Lanen D, Fowler M, Mukherjee U. Economic analysis with respect to Power-to-Gas energy storage with consideration of various market mechanisms. *Int J Hydrogen Energy* 2016;41:7754e65.
- [7] Parra D D, Patel MK. Techno-economic implications of the electrolyser technology and size for power-to-gas systems. *Int J Hydrogen Energy* 2016;41:3748e61.
- [8] Stoll RE, von Linde F. Hydrogen-what are the costs? Hydrocarbon processing. November 2000. downloadable from, <https://www.caloric.com/wp-content/uploads/2016/11/Caloric-Downloads-Wasserstoff.pdf>.
- [9] Pivovar B, Rustagi N, Satyapal S. Hydrogen at Scale: key to a clean, economic and sustainable energy system. *ECS Interface* 2018:67e72.
- [10] Saba SM, Muller M, Robinius M, Stolten D. The investment costs of electrolysis: a comparison of cost studies from the past 30 years. *Int J Hydrogen Energy* 2018;43:1209e23.
- [11] Schmidt O, Gambhir A, Staffell I, Hawkes A, Nelson J, Few S. Future cost and performance of water electrolysis: an expert elicitation study. *Int J Hydrogen Energy* 2017;42:30470e92.
- [12] Schiller M, Anderson E. Five considerations for large-scale hydrogen electrolyser development. *Gas Energy* 2014;1:44e7.
- [13] Anderson E. MW electrolysis scale up, DOE electrolytic hydrogen production workshop, NREL. February 2014. downloadable from, https://energy.gov/sites/prod/files/2014/08/f18/fcto_2014_electrolytic_h2_wkshp_anderson1.pdf.
- [14] Zeng K, Zhang D. Recent progress in alkaline water electrolysis for hydrogen production and applications. *Prog Energy Combust Sci* 2010;26:307e26.
- [15] Alleau T. Production d'hydrogène par électrolyse de l'eau, AFHYPAC Fiche 3.2.1. October 2015. p. 8. downloadable from, <http://www.afhypac.org/documents/tout-savoir/Fiche%203.2.1%20-%20Electrolyse%20de%20l%27eau%20rev%20janv.%202018%20ThA.pdf>.

[16] Rapoport S, Vanhoudt W. Study on early business Cases for H₂ in energy Storage and more broadly power-to-H₂ applications, joint Tractebel&Hincio study, financed by the fuel Cells and hydrogen 2 joint undertaking (FCH 2 JU), Brussels. June 2017. p. 66. downloadable from, http://www.fch.europa.eu/sites/default/files/P2H_Full_Study_FCHJU.pdf.

[17] Beeker E. Y a-t-il une place pour l'hydrogène dans la transition énergétique ? Note d'analyse N15 de France Stratégie. August 2014. p. 4. downloadable from, <http://www.strategie.gouv.fr/sites/strategie.gouv.fr/files/atoms/files/201-08-06na-fs-hydrogene-hd.pdf>.

[18] Thomas (Hydrogenics D, Mertens (Colruyt) D, Meeus (Sustesco) M, Van der Laak W. I. François (WaterstofNet), power-to-gas Roadmap for Flanders, Brussels. October 2016. p. 43. downloadable from, <http://www.power-to-gas.be>.

[19] Philibert C. Renewable Energy for Industry: from green energy to green materials and fuels. IEA Insight Series; 2017. p. 28. downloadable from, https://www.iea.org/publications/insights/insightpublications/Renewable_Energy_for_Industry.pdf. international journal of hydrogen energy 44 (2019) 4406e44134413

Part 3: Task Force Electrolyser Data

Critical assessment of the production scale required for fossil parity of green electrolytic hydrogen

Author: Joris Proost

Affiliation: Université catholique de Louvain, Louvain-la-Neuve, Belgium

Abstract

Hydrogen produced from renewable electricity through Power-to-Hydrogen can facilitate the integration of high levels of variable renewable electricity into the energy system. An electrolyser is a device that splits water into hydrogen and oxygen using electricity. When electricity is produced from renewable energy sources, electrolytic hydrogen can be considered to be green. At the same time, electrolysers can help integrate renewable electricity into power systems, as their electricity consumption can be adjusted to follow wind and solar power generation. Green hydrogen then also becomes a carrier for renewable electricity. Key green hydrogen production technologies, mostly PEM and alkaline electrolysers, are still further maturing, both in technical (efficiency), economical (CAPEX) and durability (lifetime) performance. Nonetheless, we will show in this contribution how fossil parity for green hydrogen, i.e. a Total Cost of Ownership (TCO) similar to grey H₂ coming from today's CO₂ intensive SMR processes, can already be achieved today. Moreover, this can be realised at a scale which corresponds to the basic units of renewable electricity generation, i.e. a few MW.

Keywords

- Power-to-hydrogen
- Electrolyser
- Renewable electricity
- Fossil parity

Introduction

The global energy system has to undergo a profound transformation to achieve the targets of the Paris Agreement. In this context, low-carbon electricity from renewables may become the preferred energy carrier. The share of renewable electricity in all of the energy consumed by end users worldwide would need to increase to 40% in 2050 (from about 4% in 2015) to achieve the decarbonised energy world envisaged by the agreement [1]. In absolute terms, this implies that the total installed renewable power capacity should increase from about 1.500 GW in 2015 to more than 15.000 GW in 2050, i.e. a 10-fold increase [2]. However, the total decarbonisation of certain sectors, such as transport, industry and applications that require high-grade heat, may be difficult purely by means of electrification. This challenge could be addressed by green hydrogen produced electrochemically from renewables (so-called Power-to-Hydrogen or P2H [3]), allowing large amounts of renewable electricity to be channeled from the power sector into these end-use sectors [4]. Renewable electricity can be used to produce green hydrogen via water electrolysis, a well-known process splitting acidified or alkalised water into ultrapure (up to 99.998%) H₂ and O₂ [5]. Such electrolytic H₂ can then further be used downstream as a green and clean chemical feedstock material in sectors otherwise difficult to decarbonise through electrification. The latter include both the chemical industry itself, as well as new applications in the transport sector [6]. As to the first, hydrogen is currently already widely used in several industrial sectors (refineries, ammonia production, bulk chemicals, etc.), with the majority of it being produced from natural gas by steam-methane reforming (SMR), a vast CO₂-intensive process [7]. Green hydrogen from renewables could replace such fossil fuel-based feedstocks in high-emission applications. For the transport sector, fuel cell electric vehicles (mainly cars and busses) provide already today an attractive low-carbon mobility option when the hydrogen is produced from renewable energy sources and offer driving performances comparable to conventional vehicles. On the longer run, H₂-based electrofuels, i.e. liquid fuels produced from renewable power, can also replace fossil fuels in the freight sector (including aviation and heavy-duty rail and trucks), without the need to change end-use technologies [8].

Although water electrolysis is already a well-established H₂ production technology for almost a century [9], its large-scale implementation for the production of green H₂ has been hampered mainly by cost issues. In a recent review [10], the production cost of hydrogen from electrolysis has been extracted from a large amount of literature data, resulting in a very wide range of cost values, ranging from about 2 €/kg to 20 €/kg. This was attributed to the large variability of the underlying assumptions and working parameters of the different sources, the production scale being the most important one [11]. Moreover, when evaluating the potential and economic viability of such green hydrogen production by water electrolysis, the current price of fossil SMR-based H₂ often appears as a rather challenging benchmark [12]. For a fair comparison though, it was recently pointed out [13] that one should always keep in mind that the industrial SMR production price is usually considered for immediate use, while often additional

storage is necessary to meet fluctuations in demand and delivery as well. On top of that, hydrogen from SMR still needs to be purified for most applications in order to reach the same grade as electrolytic one. Moreover, in such cost comparisons, the potential valorisation of ultra-pure electrolytic oxygen (8 kg for each kg of H₂) is totally neglected. In any case, on a macro-economical level, according to Ref. [14], the global hydrogen feedstock market represented in 2015 a total estimated value of 115 billion €, corresponding to a hydrogen demand of about 56 Mton/yr. By dividing the total estimated market value by the total worldwide hydrogen demand at the same year, a reasonable first-order estimation of the “average” market price for fossil H₂ can then be obtained as $115/56 \cong 2,0$ €/kg. In the current paper, we aim at critically assessing the production scale that would be required to reach such fossil parity using electrolytic hydrogen.

While doing so, it is important to acknowledge that significant regional differences may still exist on a micro-economical level. This is not only due to geographical variations in the production price of SMR H₂, but also depending on the availability of sufficient and low-cost renewable electricity. It is for instance well-known that the production cost of hydrogen from SMR is significantly influenced by natural gas prices, which account for 45%–75% of the total SMR production cost. As a result, the low gas prices in the Middle East, the Russian Federation, and North America give rise to some of the lowest hydrogen SMR production costs, sometimes even down to 1.5 €/kg [15]. On the other hand, gas importers such as Japan, Korea, China and India have to contend with higher gas import prices, which inevitably results in higher hydrogen production costs. As a result, it will be much more feasible for electrolytic hydrogen produced from renewable electricity to compete effectively with SMR in countries relying on natural gas imports and characterised by good renewable resources.

Hydrogen production

Hydrogen production today

As of today, hydrogen is being used as a specialty chemical in a number of applications. These are generally classified into 4 main categories [14], as illustrated in Table 1:

- (1)** the chemical industry, where H₂ is a basic building block for the synthesis of ammonia, methanol and a number of technical polymers;
- (2)** a number of downstream refining processes, like hydro-cracking and hydro-treating;
- (3)** iron, steel and glass manufacturing, where H₂ is the preferred reducing gas during annealing, blanketing and forming processes;
- (4)** other specialty applications, like the semiconductor industry, the use as a propellant fuel or the cooling of generators. The first two categories represent with 65% by far the largest contribution to the total H₂ demand, followed by refining, iron, steel and glass manufacturing (all together about 25%) and the remaining 10% for the other specialty applications.

Table 1. Today's major industrial sectors using H₂. For each sector, a typical unit plant size is given (in Nm³/h₂ demand), as well as the corresponding equivalent electrolyser power.

Industry Sector	Key Applications	Unit plant size (in Nm ³ /h ₂ demand)	Equivalent electrolyser power
Chemical	Ammonia (NH ₃)	80.000	400 MW
	Methanol (CH ₃ OH)	10.000	50 MW
Refining	Hydrocracking Hydrotreating	400.000	2.000 MW
Iron & Steel	Annealing Blanketing gas Forming gas	400	2 MW
General	Semiconductor Float glass production Propellant fuel Cooling of generators	50	0,25 MW

An important difference between each of these 4 categories is the scale of the so-called unit process or production size, i.e. the typical individual plant or reactor capacity required to generate the appropriate amount of H₂ feedstock in each application. Table 1 gives in this respect some indicative numbers (in Nm³/h of H₂ demand) for each of these 4 categories. In its last column, it also provides the equivalent electrolyser capacity that would be required to satisfy these unit size H₂ feedstock demands by on-site electrolytic H₂ production (assuming a state-of-the art electrolyser efficiency of 70% [16], corresponding to a renewable electricity need of 47,1 kWh/kg H₂). Large variations in production scale can be noticed across the different sectors, ranging from about 250 kW at the low-end (typical for float glass production) to a few GW at the high-end (typical for H₂ demand in refineries).

As of today, the great majority of all of the above H₂ is being delivered by a centralised, off-site hydrogen production, dominated by 2 large-scale chemical processes: steam methane reforming (SMR) and coal gasification. According to Ref. [15], these processes made up about 76% and 23% respectively of the total

H₂ production in 2018. Unfortunately, as shown in Fig. 1, both of these processes are heavily CO₂ intensive, SMR emitting up to 8 tons of CO₂ per ton of H₂ produced. Therefore, with the objective of reaching the CO₂ emission targets in today's fossil based H₂ production, the part of green electrolytic hydrogen production from renewable electricity (which represents less than 4% today) can be expected to significantly increase over the coming years. In order to meet the current global H₂ demand of around 60 Mton/year, a total of 300 GW installed electrolyser capacity would be needed. As this represents today about 20% of the total installed renewable power capacity, such massive electrolyser deployment is currently not very realistic. As a result, a selection of technologically feasible market penetrations for electrolytic H₂ needs to be made. Such selection also implies that today's local H₂ consumers, besides becoming local (on-site) producers of renewable electricity, also need to become local (on-site) producers of electrolytic H₂, at a production scale which still allows to meet the stringent requirement of fossil parity at about 2,0 €/kg. On the longer run, with the projected 10-fold increase in renewable power to 15.000 GW in 2050, a mere 2% use of this capacity would be required to satisfy the equivalent 300 GW water electrolysis demand. This can be considered to be within the range of grid balancing services, making such green electrolytic hydrogen production on the long run an even more viable and attractive alternative hydrogen production technology.

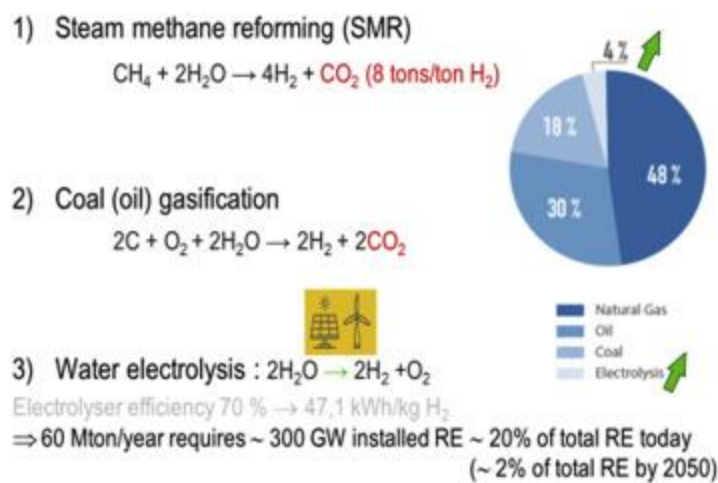

Fig. 1. Summary of today's main hydrogen production technologies.

The above suggested transformation from centralised (off-site) fossil-based H₂ production to a decentralised (on-site) green electrolytic H₂ production provides a significant paradigm shift, allowing local consumers to become local producers as well. Up to now, in an industry largely governed by CO₂-intensive chemical processes, such a local H₂ production in line with the local H₂ consumption was simply not feasible, because of the minimum production scale required for both SMR and coal or oil gasification.

The latter typically starts at a few 10.000 Nm³/hr (about 8000 ton/yr) for the smallest unit size installations, equivalent to a 50 MW electrolyser. As can be seen in Table 1, this largely exceeds the industry needs in a number of applications (iron & steel, as well as general industry). Moreover, additional CO₂-intensive logistics (incl. Transport, compression and storage) are required in these applications as well.

Green hydrogen production scale-up

Contrary to the intrinsically large-scale SMR, water electrolysis is intrinsically small-scale, as illustrated in Fig. 2. Both the geometrical area of the electrodes (a few m² at most) and the number of electrodes that can be compiled in series in a single stack is relatively limited. As a result, the unit size of water electrolyzers has long been limited to the kW-range, a typical on-site containerized production unit being a few 100 kW at most. However, in order to be able to realise the mandatory coupling to renewables, mainly wind and solar, the power scale of water electrolyzers needs to become of the same order of magnitude as the renewable electricity source itself. As illustrated in Fig. 3 (reproduced from Ref. [17]), this requires a major scale-up from the kW-scale, typical for state-of-the-art electrolyzers about a decade ago, towards the multi-MW scale typical for state-of-the-art on-shore wind turbines today. Fig. 3 also shows that this mandatory scale-up has the potential to significantly reduce the investment cost (CAPEX) of electrolyzers, potentially reaching the same order of magnitude as small-scale SMR installations from the MW-level onwards.

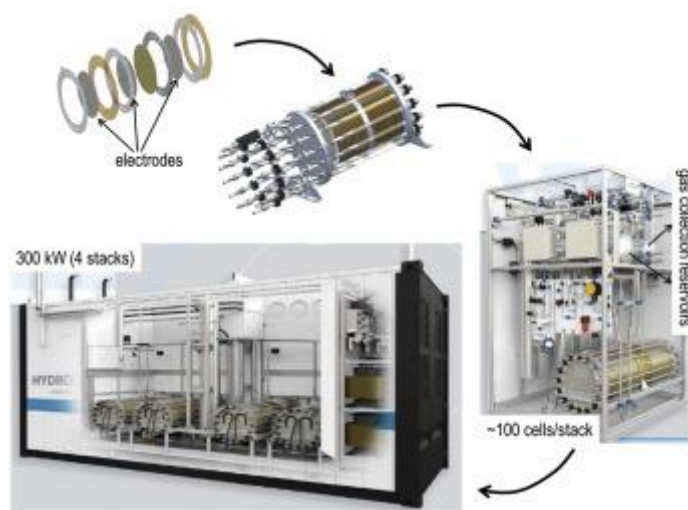

Fig. 2. A typical unit size configuration for an industrial alkaline water electrolyser.

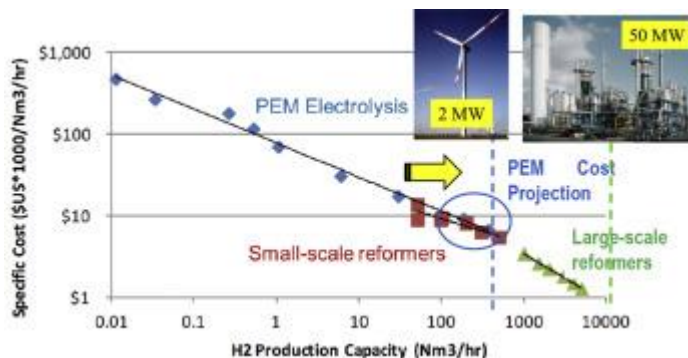

Fig. 3. Projected cost reduction associated with a scale-up of green electrolytic hydrogen production. The blue diamonds represent real CAPEX data for PEM electrolysers, except for the ones between 100 and 1000 Nm³/hr, which are cost projections. The red squares and green triangles are real SMR CAPEX data for small-scale (on-site) and large-scale (centralised) reformers, respectively. Taken from Refs. [17]. (For interpretation of the references to color in this figure legend, the reader is referred to the Web version of this article.)

Such an electrolyser scale-up has initially been realised by increasing the number of cells per stack, as illustrated in Fig. 2. However, from the state-of-the-art data that we recently collected from a number of electrolyser manufacturers, such a “keep-on-stacking” approach seems to have a practical limit at around 100 cells/stack [18]. Beyond that number, other balance-of-plant issues come into play, including the risk of electrical shorts [19] and the technological complexity of a safe large-scale gas collection [20]. There are also a number of specific issues related to electrochemical reactor design, like the increased risk of a non-homogenous electrolyte distribution when pumped through a larger stack [21], and a non-homogeneous current distribution within the different cells [22]. Note that this apparent 100-cell limitation is by no means a stringent intrinsic limitation, but rather an empirical observation based on the above cited industrial data. In other words, it appears that for a number of electrochemical and/or technical reasons, electrolyser manufacturers are currently preferring to upscale production capacity modularly, rather than increasing the capacity of a single stack.

As a result, for (multi-)MW applications, multi-stack electrolyser systems are typically being used. As an example, Fig. 4 shows both an iconic historical illustration of a 135 MW alkaline electrolyser plant dating back already from 1953 [23], and a number of today's multi-MW plant designs from a major electrolyser manufacturer, based on a single stack electrolyser of 2,2 MW [24].

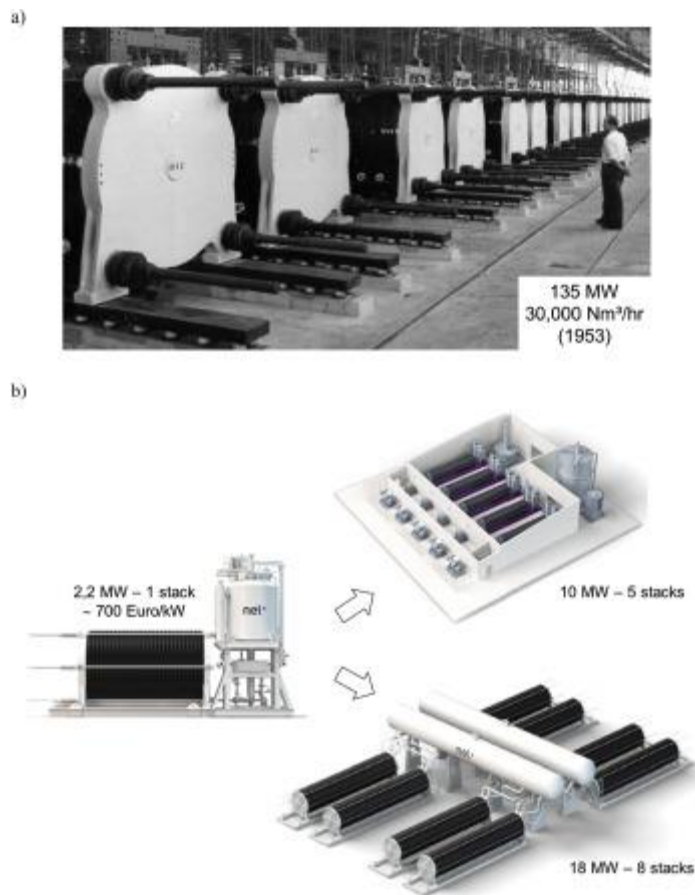

Fig. 4. Examples of multi-stack alkaline electrolyser systems: (a) A 135 MW electrolyser plant from 1953 [23]; (b) Current multi-MW plant designs from a major electrolyser manufacturer, based on a single stack electrolyser capacity of 2,2 MW [24].

Fossil parity for green hydrogen

The cost of electrolytic hydrogen

While Fig. 5 shows that it is technically feasible to produce green electrolytic hydrogen at the multi-MW scale (even > 100 MW), the critical question still remains at what price/cost. Clearly, if green H₂ is to become competitive with today's "grey" SMR H₂, it should be made available at its current market price, i.e. around 2,0 €/kg. In this respect, Fig. 5 illustrates the effect of the 3 major parameters affecting the electrolytic H₂ production cost: the operational time of the electrolyser (in full load hours or FLH), the cost of renewable electricity (ELCTR, in €/MWh), and the electrolyser CAPEX (CPX, in €/kW). The basic equation used for this first-order cost simulation is as follows

Task 38 Final Report - September 2020

$$(1) \text{ H}_2 \text{ cost}(\text{€}/\text{kg}) = (\text{ELCTR}/1000 + \text{CPX}/10 \cdot 1/\text{FLH}) \cdot \varepsilon$$

where ε represents the electrolyser power consumption (in kWh/kg). With respect to the latter, the theoretical minimum value ε_{th} for obtaining H_2 through electrochemical water splitting can simply be calculated based on a 2 electron reduction step

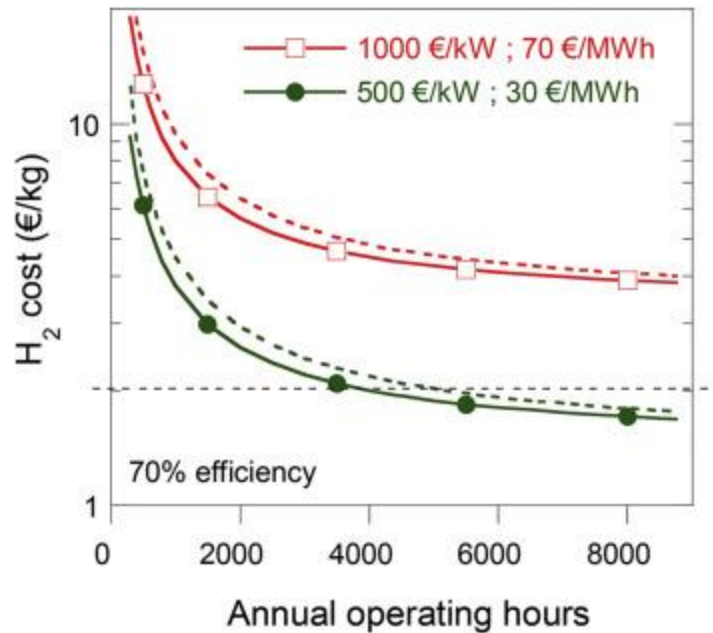
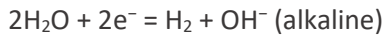
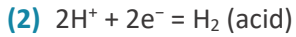

Fig. 5. Electrolytic H_2 production cost as function of electrolyser's annual operating time (1 yr = 8760 h), simulated according to Eq. (1) for two different CAPEX/electricity cost combinations. The electrolyser's efficiency was fixed at 70%, corresponding to 47,1 kWh/kg. The additional dashed trendlines for the 2 data sets include, besides the electricity cost, also an additional fixed OPEX cost equal to 30% of CAPEX.

With 1 kg of H_2 requiring $10^3 F$ Coulomb (F being Faraday's constant), 1 kg/h of H_2 then corresponds to an electrical current of $(96487 \cdot 10^3)/3600 = 26802$ A. Multiplied by the theoretical water decomposition potential of 1.23 V, this then gives a theoretical minimum power consumption $\varepsilon_{\text{th}} = 33$ kWh/kg. A typical electrolyser efficiency being 70% [16], a typical ε -value to be used in Eq. (1) is therefore $33/0.7 = 47.1$ kWh/kg. Also note that in Eq. (1), the factor 1/1000 in the first term serves to convert MWh into kWh, while the factor 1/10 in the second term comes from a linear depreciation for a 10 years electrolyser operation.

First of all, for the red set of parameters in Fig. 5, i.e. a CAPEX of 1000 €/kW and a renewable electricity cost of 70 €/MWh (as taken from [25], a reference which dates back already from 2014), it is clear that producing H₂ from water electrolysis is not always economically viable with respect to the current SMR benchmark price of 2 €/kg. In particular, before becoming a realistic alternative production technology, there is a need for cheap (er) renewable electricity (well below 70 €/MWh), the investment cost of electrolyzers needs to be brought down (well below 1000 €/kWh), and there should preferably also be a clear industrial commitment to CO₂ reduction. The latter might notably impose an additional tax/cost to SMR H₂, helping to further close the gap with electrolytic H₂.

Luckily, with respect to the red parametric values used in Fig. 5, significant progress has been made since 2014, both in reducing the price of renewable electricity and in reducing the electrolyser CAPEX. As to the first, Fig. 6, taken from a recent study from the International Energy Agency (IEA) [26], shows the projected reduction in average auction prices for renewable electricity from both solar PV and on-shore wind. Clearly, prices on the order of 30 €/MWh can be expected to be realistic already as of 2020. At the same time, this very study also projects load factors of combined wind and solar power to exceed 50% in vast areas. A recent German field study reporting on the operational experience of a 6 MW Power-to-Hydrogen demonstration plant seems to confirm these promising numbers [27]. During its initial testing phase, when operation time was limited to 8 h during working days, the electrolyser load demand curve led to an average electricity cost (as purchased from the EPEX SPOT day-ahead auction market) of about 36 €/MWh. After full automation of the plant to a 24/7 operation so that electricity could be bought in times of low spot prices, additional cost savings of more than 15 €/MWh could be realised.



Fig. 6. Documented and extrapolated decrease in average auction prices for renewable electricity from solar PV and on-shore wind (from Refs. [26]).

Secondly, as to the electrolyser CAPEX, Fig. 7 shows state-of-the-art data from NEL, one of the world's largest alkaline electrolyser manufacturers. They clearly show a significant decrease well below the value

of 1000 €/kW used for the red data set in Fig. 5. In particular, a CAPEX value of 750 €/kW, considered by utility providers to be the capital cost for storing renewable electricity, is already realistic today for a single stack 2 MW system. Moreover, a significant further reduction in CAPEX as low as 500 €/kW is projected for multi-stack systems when scaling up to 50–100 MW. Also note from Fig. 7 that single stack electrolyzers are much more susceptible to CAPEX reduction than multi-stack systems when upscaled.

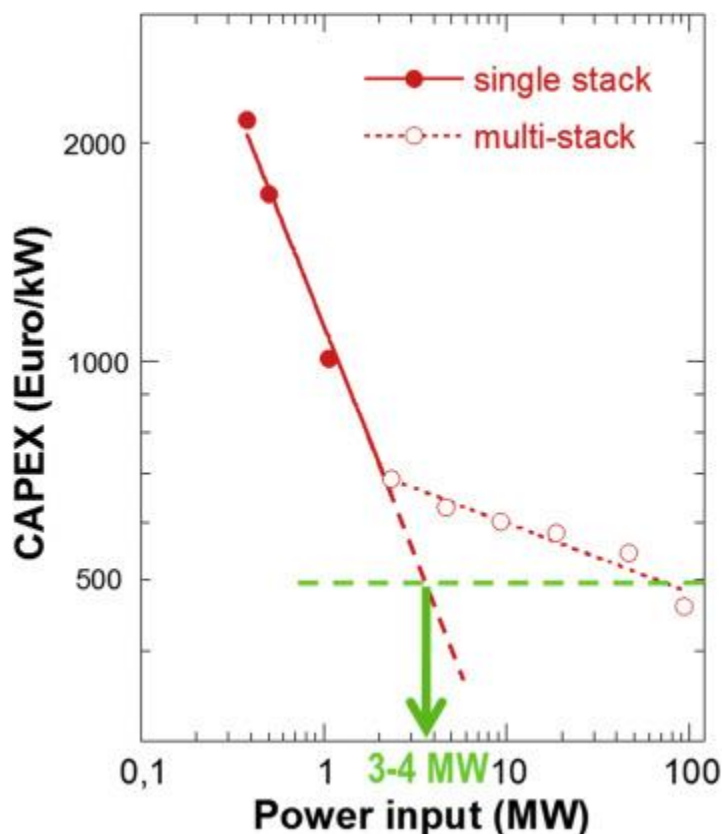

Fig. 7. State-of-the-art CAPEX data for alkaline electrolyzers as a function of power input. The change in slope for alkaline electrolyzers corresponds to the use of multi-stack systems.

Based on the above updated numbers, the green data set in Fig. 5 then allows to anticipate a significant reduction in the electrolytic H₂ production cost. Indeed, assuming the most favorable but still realistic CAPEX value of 500 €/kW in combination with an electricity cost of 30 €/MWh and a state-of-the-art electrolyser efficiency of 70% (i.e. 47,1 kWh/kg), green electrolytic H₂ can indeed start competing with SMR from 4500 operating hours onwards (i.e. a load factor of about 50%). Note that under these conditions, the total H₂ cost calculated from Eq. (1) comes down to 1,95 €/kg and is mainly determined by the electricity cost, which represents $47,1 \times 0.03 = 1,41$ €/kg or 72%. One should therefore be aware that any efforts to further reduce the CAPEX of alkaline water electrolyzers below 500 €/kW will only have a

minor overall effect. For instance, for a CAPEX of 250 €/kW, Fig. 8(a) shows that the total H₂ cost goes down to 1,68 €/kg, of which only 15% would come from the very stringent techno-economical measures needed to reach such low CAPEX value.

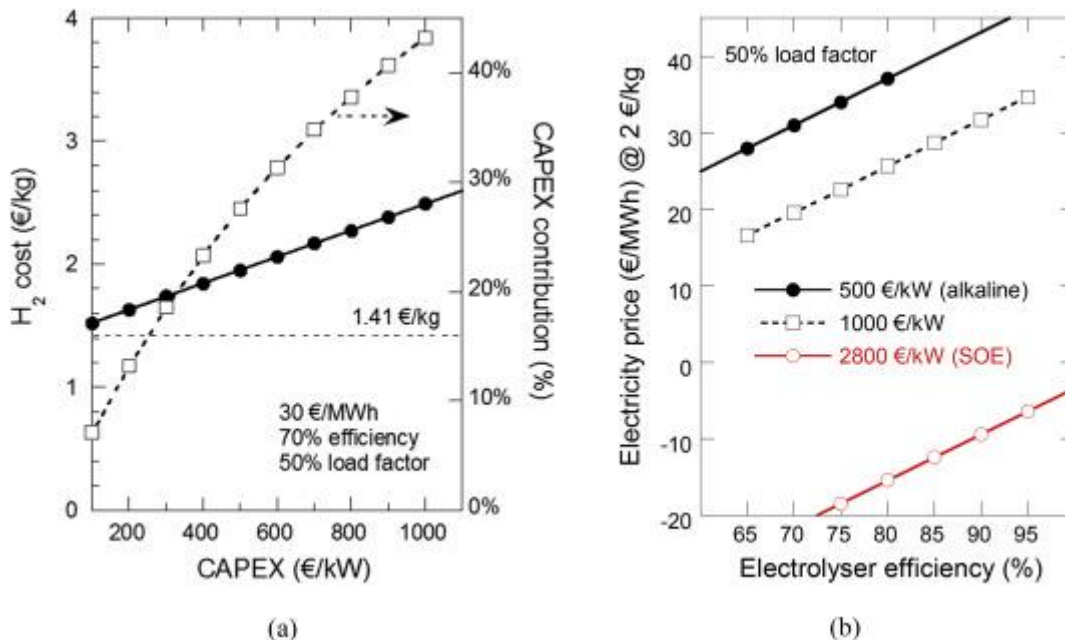

Fig. 8. (a) Simulated electrolytic H₂ production cost as a function of electrolyser CAPEX, assuming a 70% efficiency (i.e. 47,1 kWh/kg) and a 50% load factor (i.e. 4380 h/year). Renewable electricity price was fixed at 30 €/MWh, corresponding to 47,1* 0.03 = 1,41 €/kg. The right axis gives the resulting % contribution of the electrolyser CAPEX to the total H₂ cost; (b) Renewable electricity price (in €/MWh) as a function of electrolyser efficiency to arrive at an electrolytic H₂ cost of 2,0 €/kg for three different CAPEX values (500, 1000 and 2800 €/kW).

Instead, Eq. (1) indicates that it will be much more effective to focus technological efforts on improving the electrolyser's electrochemical efficiency, since the related power consumption ϵ is a common factor to both the OPEX and CAPEX part. The main effect of an efficiency increase, which is equivalent to a lower kWh/kg H₂ electricity consumption, is that it allows to relax the sometimes rather stringent conditions on the renewable electricity price needed to reach fossil parity. In this respect, Fig. 8(b) shows, as a function of electrolyser efficiency, the renewable electricity price (in €/MWh) that would be needed to arrive at an electrolytic H₂ cost of 2,0 €/kg for three different CAPEX values: 500, 1000 and 2800 €/kW. The last one can be considered, according to Ref. [15], to be a realistic CAPEX target value by 2030 for solid oxide electrolyzers (SOE). These are especially known for their high intrinsic efficiency (up to 90%) resulting from high temperature operation (650–1000 °C). Nonetheless, from the negative red data in Fig. 9(b), it can be

seen that even in that case the higher SOE efficiency will still not be able to provide electrolytic H₂ at fossil parity. This would require SOE CAPEX values to decrease even further, down to a level of 1000 €/kW.

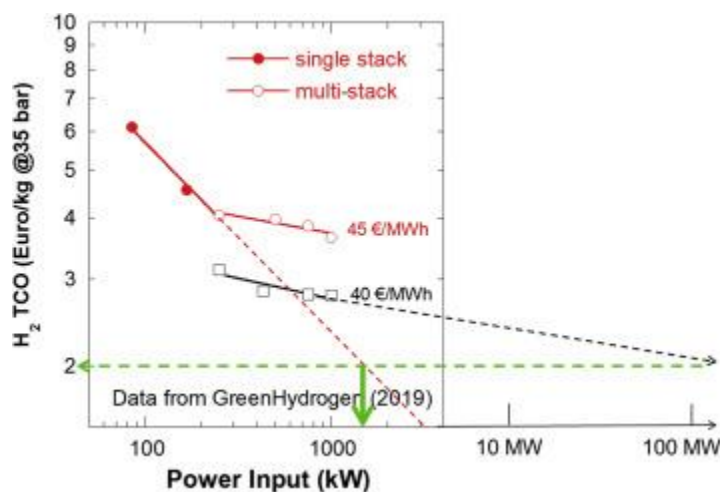

Fig. 9. Total Cost of Ownership (TCO) of electrolytic H₂ (delivered at 35 bar) as a function of power input, obtained from the Danish electrolyser manufacturer GreenHydrogen. Prices are based on a 10 years operation (including a 10 year's service and maintenance agreement) for a complete turnkey, containerized alkaline electrolyzer unit (including inverter and water treatment), delivered and installed in Europe. OPEX includes the use of electricity, water and nitrogen (for purge), assuming a renewable electricity price of 40 and 45 €/MWh, respectively.

We do acknowledge that the trends presented in Fig. 5, Fig. 8 should be considered to be a first-order cost simulation, based on the rather basic Eq. (1). For instance, most other economic analyses tend to add a yearly interest rate (typically 7–10%) and in some cases an additional OPEX contribution on top of electricity cost (up to 30% of CAPEX). We have decided here not to do so, as the exact numbers are often rather arbitrary chosen. Moreover, they barely change the principal trends induced by varying the major parameters (i.e. electricity price, capacity factor, CAPEX and efficiency), which are already included in our basic Eq. (1). This has been explicitly illustrated in Fig. 5 by the two additional dashed trendlines, which include an additional fixed OPEX cost equal to 30% of CAPEX.

Finally, for a fair comparison, an additional CO₂ price for SMR H₂ should be taken into account as well [28]. In this respect, the seminal IEA report *“The Future of Hydrogen”* [15] predicts an average increase of 50% in the hydrogen production cost from SMR when imposing a carbon price of 100\$/tCO₂. This might even trigger the large-scale implementation of CCUS, which would become economically attractive if CO₂ prices were above 50\$/tCO₂. Adding CCUS to SMR plants would then lead in turn to cost increases of about 50%

in terms of CAPEX and 10% for fuel, the exact amounts depending on the plant design. It also leads on average to a doubling of OPEX as a result of CO₂ transport and storage costs [15]. Nonetheless, our above projections, without considering any carbon price, are sufficiently promising as such to stimulate already today a further penetration of water electrolyser technology for renewable energy storage purposes. At the same time, they should also provide confidence for the ultimate consideration of electrolytic H₂ as a basic chemical building block, enabling direct coupling to renewable electricity production and hence helping to green the chemical feedstock industry.

The scale of fossil parity for green hydrogen

A final issue then relates to the production scale that is required for obtaining such fossil parity with electrolytic H₂. Indeed, from the data in Fig. 7, one could wrongly conclude that reaching the required reduction in electrolyser CAPEX down to 500 €/kW would require very large-scale electrolytic H₂ production units, on the order of 100 MW. In that case, the minimum scale for economically viable electrolytic H₂ production would need to become similar to current SMR installations (cfr. Fig. 3). As already suggested from Table 1, for some feedstock applications, like ammonia or methanol production, such a large unit size can be relevant even for an on-site, decentralised green H₂ production. However, Fig. 7 indicates that there might still be a much smaller production scale for reaching such low CAPEX values. Indeed, when extrapolating the CAPEX data of single-stack alkaline electrolysers in Fig. 7, the level of 500 €/kW (dashed horizontal green line) can already be reached around 3–4 MW. Such a significant reduction in the scale required for fossil parity is directly related to the much steeper reduction in CAPEX that can be realised for single-stack as compared to multi-stack systems. A straightforward consequence of the above observation is that the minimum investment cost needed to install electrolytic hydrogen production units capable of delivering green H₂ at fossil parity goes down significantly as well: from about $100 \cdot 10^3 \cdot 500 = 50$ M€ to a mere 200 k€, a very realistic number in view of a local, decentralised production.

Even more direct corroborating evidence for this relatively small-scale fossil parity for green electrolytic H₂ is provided in Fig. 9. The latter presents state-of-the-art industrial data for the Total Cost of Ownership (TCO) of electrolytic H₂ as a function of power input, as obtained from GreenHydrogen, a Danish electrolyser manufacturer who produces pressurized stacks. Values are based on a 10-year operation, including a 10 years' service and maintenance agreement, for a complete turnkey, containerized alkaline electrolyzer unit (including inverter and water treatment), delivered and installed in Europe. The electrolyser power consumption is guaranteed at 46.7 kW/kg and delivers H₂ at 35 bars. The hydrogen production cost in Fig. 9 also takes into account the OPEX part, including the use of water, nitrogen (for purge) and electricity, assuming a renewable electricity price of 40 and 45 €/MWh, respectively. A number of striking observations can be made from this figure. First of all, these TCO data confirm the trend already

observed in Fig. 7, namely the much steeper decrease in unit price for hydrogen delivered from a single stack vs. a multi-stack system. Secondly, until now, it was commonly agreed that the only option to decrease the electrolytic H₂ production cost towards fossil parity was to increase the capacity of the (multi-stack) system up to 50–100 MW, as already discussed with Fig. 7. Fig. 9 now clearly shows that in that case, even a decrease in renewable electricity cost (from 45 to 40 €/MWh) only slightly affects the scale of fossil parity, due to the relatively small decrease in TCO with power typical for such multi-stack systems. As a result, large-scale electrolyser systems would still be necessary to reach fossil parity. However, as suggested by the dashed red line in Fig. 9 through the TCO data for single stack systems, there is another technological alternative. It consists of extending the power input that can be taken up by a single stack electrolyser up to a few MW, the exact power depending on the electrolyser technical characteristics. This then also corresponds to the scale of the basic units of renewable electricity generation. Also note that when considering an even more stringent SMR price level of 1.5 €/kg (corresponding in Fig. 9 to the horizontal axis rather than the dashed green line at 2.0 €/kg), our conclusions on the required scale for reaching fossil parity do not fundamentally change. Indeed, in that case, extrapolation of the single-stack TCO data would arrive at 3 MW, instead of 1.5 MW for 2.0 €/kg.

Note that at this stage, there is not really a rigorous scientific reasoning behind the single-stack cost line extrapolations in Fig. 7, Fig. 9. It is a mere empirical observation, but still a rather reliable one since based on two independent industrial data sets over a relatively large power scale. It is also important to realise that the obtained extrapolated single-stack power for fossil parity is not a unique number, but something that is specific to each stack geometry (e.g. the number and area of electrodes used). For instance, the Norwegian HydrogenPro already has a 3.7 MW single-stack alkaline electrolyser on the market, while the Belgian-Chinese Cockerill Jingli Hydrogen even sells 7.5 MW single-stacks, to the best of our knowledge the largest single-stack on the market.

The challenge on the electrolyser level is then to try to technologically implement this single-stack extrapolation in order to arrive at higher single-stack power levels. As the number of cells/stack seems to have reached its limit [18], an alternative option is to increase the specific area of each individual electrode, e.g. by replacing classical 2-D plates by 3-D foams [29,30] hence allowing for a higher current density operation [31]. Incidentally, a recent European demonstration project (Demo4Grid) showing the technical feasibility and greening potential of a single-stack 4 MW alkaline electrolyser has been launched in that sense [32]. Such small-scale fossil parity has the important advantage of allowing a decentralised local H₂ production. Renewables can then be harvested anywhere and used directly for the local production and consumption of green electrolytic hydrogen. This will not only allow to open up today's market to electrolytic H₂ in a number of small unit scale segments (like iron & steel and glass manufacturing, cfr. Table 1), but also to widen the use of green electrolytic H₂ to a number of new small-scale markets (like the food industry targeted in Ref. [32]). This is a significant paradigm shift with respect

to the current large-scale fossil fuels (SMR) based centralised hydrogen production, the latter also requiring an additional cost to transport the H₂, both in terms of €/kg and CO₂ footprint.

Conclusion

In this paper, we have addressed the question what would be an economically viable (minimum) production scale for green hydrogen, produced from water electrolysis using renewable electricity. A realistic benchmark to do so is the current price of grey hydrogen produced by fossil-based and thus CO₂ intensive processes (the so-called fossil parity), currently estimated at 2,0 €/kg. Firstly, we acknowledged the promising market opportunities for such green hydrogen in today's H₂ markets. The latter represent about 60 Mt/yr, and can be classified in 4 major applications, all of them having their own typical unit size in terms of equivalent H₂ demand, ranging from a few hundreds of kW up to several GW. Secondly, it was shown how, based on current state-of-the-art CAPEX data for today's multi-stack electrolyzers and using a renewable electricity price of 30 €/MWh, such fossil parity can be reached already today at 50–100 MW. This is about the same scale as the smallest SMR installations. Finally, using the most recent TCO values for electrolytic hydrogen, it was concluded that fossil parity could potentially also be reached at a much smaller production scale, on the order of a few MW. Although this still requires a further intensification of the water electrolysis process, e.g. by extending the power range of a single-stack electrolyser, such small-scale fossil parity provides an important paradigm shift. Indeed, with respect to the current, large-scale fossil fuels (SMR) based centralised hydrogen production, it has the important advantage of allowing a decentralised local H₂ production. Renewables can then be harvested anywhere and used directly for the local production and consumption of green electrolytic hydrogen, in line with the small-scale local H₂ demand.

Acknowledgements

We cordially thank Eric Dane from NEL and Henrik Steen Pedersen from GreenHydrogen for providing their state-of-the-art CAPEX and TCO data on electrolytic hydrogen. This paper was realised within the framework of the Hydrogen Technology Collaboration Programme (TCP) of the International Energy Agency (IEA), more specifically Task 38 on Power-to-Hydrogen. It also benefited from a number of insightful discussions with Uwe Remme and Cédric Philibert at the IEA's Energy Technology Policy Division and the Renewable Energy Division, respectively. Finally, financial support from the Public Service of Wallonia – Dept. Of Energy and Sustainable Building is gratefully acknowledged for allowing these fruitful interactions with the IEA.

REFERENCES

- [1] E. Pursiheimo, H. Holttinen, T. Koljonen, Inter-sectoral effects of high renewable energy share in global energy system, *Renew Energy*, 136 (2019), pp. 1119-1129
- [2] report IRENA report 2018, Global Energy Transformation: A Roadmap to 2050, (for download from www.irena.org/publications).
- [3] M. Götz, J. Lefebvre, F. Mörs, A. McDaniel Koch, F. Graf, S. Bajohr, R. Reimert, T. Kolb, Renewable Power-to-Gas: a technological and economic review, *Renew Energy*, 85 (2016), pp. 1371-1390
- [4] J.O.M. Bockris, The origin of ideas on a Hydrogen Economy and its solution to the decay of the environment, *Int J Hydrogen Energy*, 27 (2002), pp. 731-740
- [5] L. Bertuccioli et al., report Study on development of water electrolysis in the EU, FCH JU Report 2014, (downloadable from <http://www.fch.europa.eu/node/783>).
- [6] G. Gahleiter, Hydrogen from renewable electricity : an international review of power-to-gas pilot plants for stationary applications, *Int J Hydrogen Energy*, 38 (2013), pp. 2039-2061
- [7] J.D. Holladay, J. Hu, D.L. King, Y. Wang, *An overview of hydrogen production technologies*, *Catal Today*, 130 (2009), pp. 244-260
- [8] S. Brynolf, M. Taljegard, M. Grahn, J. Hansson, Electrofuels for the transport sector: a review of production costs, *Renew Sustain Energy Rev*, 81 (2018), pp. 1887-1905
- [9] K. Zeng, D. Zhang, Recent Progress in alkaline water electrolysis for hydrogen production and applications, *Prog Energy Combust Sci*, 36 (2010), pp. 307-326
- [10] G. Maggio, A. Nicita, G. Squadrito, How the hydrogen production from RES could change energy and fuel markets: a review of recent literature, *Int J Hydrogen Energy*, 44 (2019), pp. 11371-11384
- [11] P. Fragiaco, M. Genovese, Modeling and energy demand analysis of a scalable green hydrogen production system, *Int J Hydrogen Energy*, 44 (2019), pp. 30237-30255
- [12] T.R. Ayodele, J.L. Munda, Potential and economic viability of green hydrogen production by water electrolysis using wind energy resources in South Africa, *Int J Hydrogen Energy*, 44 (2019), pp. 17669-17687
- [13] A. Nicita, G. Maggio, A.P.F. Andaloro, G. Squadrito, Green hydrogen as feedstock: financial analysis of a photovoltaic-powered electrolysis plant, *Int J Hydrogen Energy*, 45 (2020), pp. 11395-11408
- [14] report IRENA report 2018 : Hydrogen from renewable power : technology Outlook for the energy transition (for download from www.irena.org/publications).
- [15] IEA report 2019, The future of hydrogen, prepared by the IEA for the G20 summit (June 2019) Japan, available for download at <https://www.iea.org/topics/hydrogen/>
- [16] R.L. Leroy, C.T. Bowen, D.J. Leroy, The thermodynamics of aqueous water electrolysis, *J Electrochem Soc*, 127 (1980), pp. 1954-1962

- [17] report IEA/HIA Task 33 report : local hydrogen production for energy applications (<http://ieahydrogen.org/pdfs/2016-06-15-IEA-HIA-Task-33-Ulleberg.aspx>).
- [18] J. Proost, State-of-the art CAPEX data for water electrolyzers, and their impact on renewable hydrogen price settings, *Int J Hydrogen Energy*, 44 (2019), pp. 4406-4413
- [19] D.L. Stojic, M.P. Marceta, S.P. Sovilj, S.S. Miljanic Hydrogen generation from water electrolysis – possibilities of energy saving, *J Power Sources*, 118 (2003), pp. 315-319
- [20] M. Schiller, E. Anderson, Five considerations for large-scale hydrogen electrolyser development, *Gas for Energy*, 1 (2014), pp. 44-47
- [21] F.C. Walsh, C. Ponce de Léon, Progress in electrochemical flow reactors for laboratory and pilot scale processing, *Electrochim Acta*, 280 (2018), pp. 121-148
- [22] R.S. Jupudi, H. Zhang, G. Zappi, R. Bourgeois, Modeling bubble flow and current density distribution in an alkaline electrolysis cell, *J Comput Multiph Flows*, 1 (2009), pp. 341-348
- [23] H.G. Langås Large-scale hydrogen production, workshop on renewable energy and hydrogen export, Trondheim (2015), for download at <https://www.sintef.no/contentassets/9b9c7b67d0dc4fbf9442143f1c52393c/9-hydrogen-production-in-large-scale-henning-g.-langas-nel-hydrogen.pdf>
- [24] taken from NEL Hydrogen brochure, Atmospheric Alkaline Electrolyser A Series (available at: <https://nelhydrogen.com/products/>).
- [25] É. Beeker, Y a-t-il une place pour l'hydrogène dans la transition énergétique ? Note d'analyse N°15 de France Stratégie (August 2014), p. 4, downloadable from <http://www.strategie.gouv.fr/sites/strategie.gouv.fr/files/atoms/files/201-08-06na-fs-hydrogene-hd.pdf>
- [26] C. Philibert, Renewable energy for industry: from green energy to green materials and fuels, IEA Insight Series (2017), p. 28, downloadable from https://www.iea.org/publications/insights/insightpublications/Renewable_Energy_for_Industry.pdf
- [27] M. Kopp, D. Coleman, C. Stiller, K. Scheffer, J. Aichinger, B. Scheppat, Energiepark Mainz, Technical and economic analysis of the worldwide largest Power-to-Gas plant with PEM electrolysis, *Int J Hydrogen Energy*, 42 (2019), pp. 13311-13320
- [28] R.E. Stoll, F. von Linde, Hydrogen - what are the costs? Hydrocarbon processing (November 2000), downloadable from <https://www.caloric.com/wp-content/uploads/2016/11/Caloric-Downloads-Wasserstoff.pdf>
- [29] D. Pletcher, X. Li, Prospects for alkaline zero gap water electrolyzers for hydrogen production, *Int J Hydrogen Energy*, 36 (2011), pp. 15089-15104
- [30] Q. de Radiguès, G. Thunis, J. Proost, On the use of 3-D electrodes and pulsed voltage for the process intensification of alkaline water electrolysis, *Int J Hydrogen Energy*, 44 (2019), pp. 29432-29440

[31] M. Schalenbach, O. Kasian, K.J. Mayrhofer, An alkaline water electrolyzer with nickel electrodes enables efficient high current density operation, *Int J Hydrogen Energy*, 43 (2018), pp. 11932-11938

[32] Demo4Grid : Demonstration for grid services production of green hydrogen greening of industry (<https://www.demo4grid.eu/>).

Part 4: Task Force Security Services

Power to hydrogen's role in ancillary markets of power networks

Author: Rob Dickinson¹, Samantha Hillard², Christine Mansilla³

Affiliation:

(1) Hydricity Systems; and University of Adelaide, Centre for Energy Technology, Adelaide, Australia

(2) Clean Horizon, France

(3) I-tésé, CEA Saclay, France

Introduction

To set up the context for this Chapter, it's necessary to distinguish at the outset between the following two distinct electricity system operation markets :

- 1) Two way electrical energy commodity trading (EECT)

- 2) Electricity system security markets (ESSM)

The second, ESSM, is also designated as **ancillary markets**. Like most terms this can mean subtly different things to different people. Here we use it in the broadest (dictionary definition) sense: markets that **provide support** to the primary market (electrical energy commodity trading).

Electrical energy commodity trading (EECT)

The notion of soaking up “excess variable renewable energy (VRE)” using power to hydrogen is well known and is discussed in other parts of this Final Report. This includes “power to gas”: power to hydrogen to injection into natural-gas networks. This is part of EECT (buying or selling electricity) and not does provide support to EECT. Other sometimes ill-defined concepts include “demand response”. This term was originally coined to refer to very large consumers being willing to drop out of the consumption market during rare but high-power price periods resulting from conventional demand approaching current supply availability. In contrast, power to hydrogen’s primary role in EECT will be buying low-cost power during periods otherwise low demand, far more than “not buying” during period of high demand. Prospective power to hydrogen participation in EECT markets in terms of response times is graphically outlined in Fig 3.1.

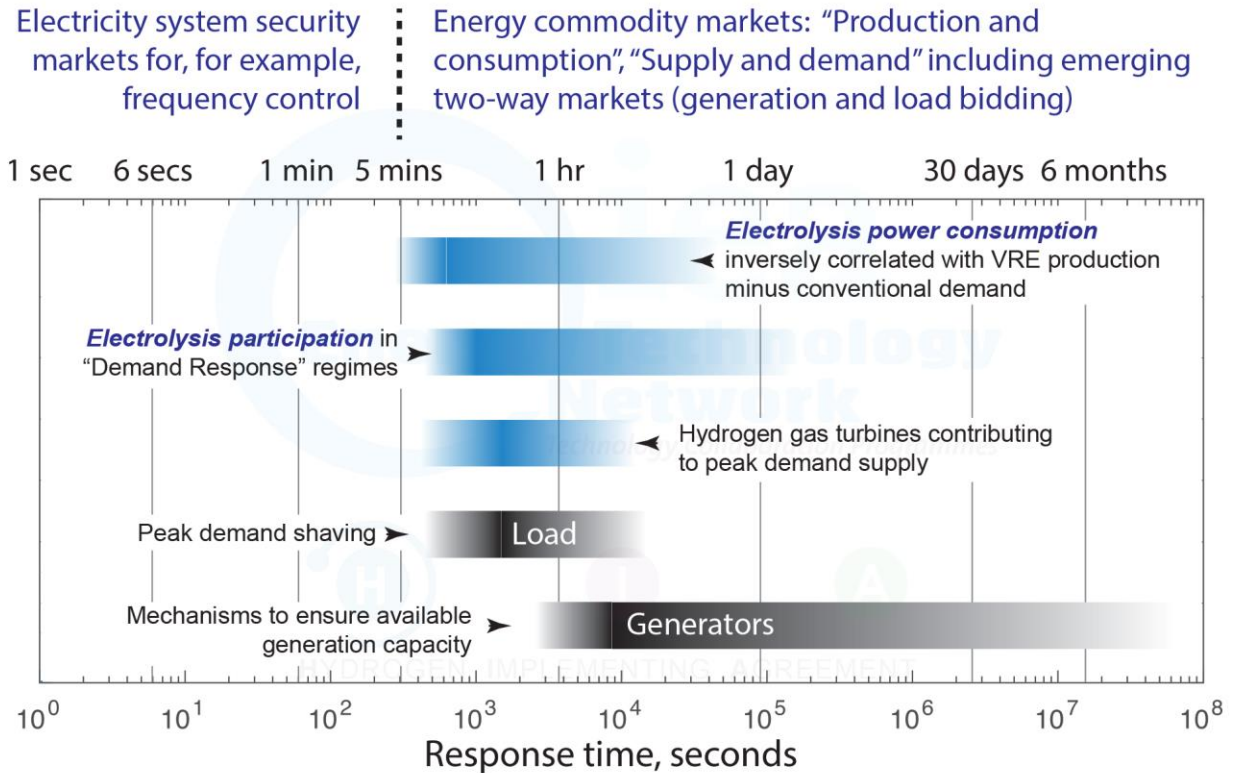

Fig 3.1 Prospective participation of power to hydrogen in electricity energy commodity trading (EECT)

Further, electricity market operation rules for supporting **two way markets** are now emerging, whereby electricity producers will continue to bid to supply, but will soon do so **concurrently** with electricity consumers bidding for consumption. That is, the choice of whether or not to consume power to produce hydrogen, and if so, how much power, will soon be made on the basis of price bids (willingness to pay) submitted to the operator every 5 minutes. This is expected to yield Certifiable clean hydrogen as a result of the increasingly clear, inverse relationship between (VRE - conventional demand) and price: When VRE production increases concurrently with conventional demand decreasing, the power price decreases. This is graphically outlined in Figs 3.2 to 3.7.

“Load duration / average price curves” for SA: 3 x 4-year periods; graphically clipped to below average scaled offset demand

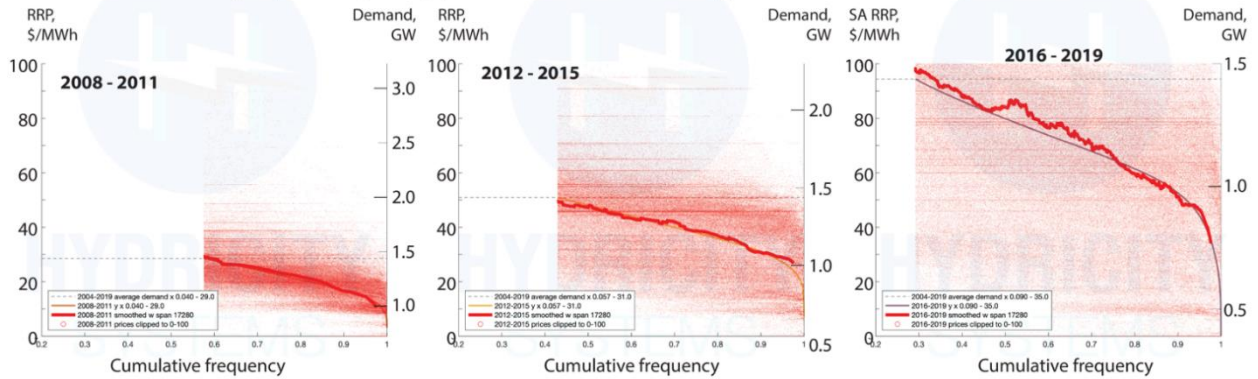

Fig 3.2 Profiles of the increasing frequency of below-average-demand prices in the SA Region of Australia’s NEM

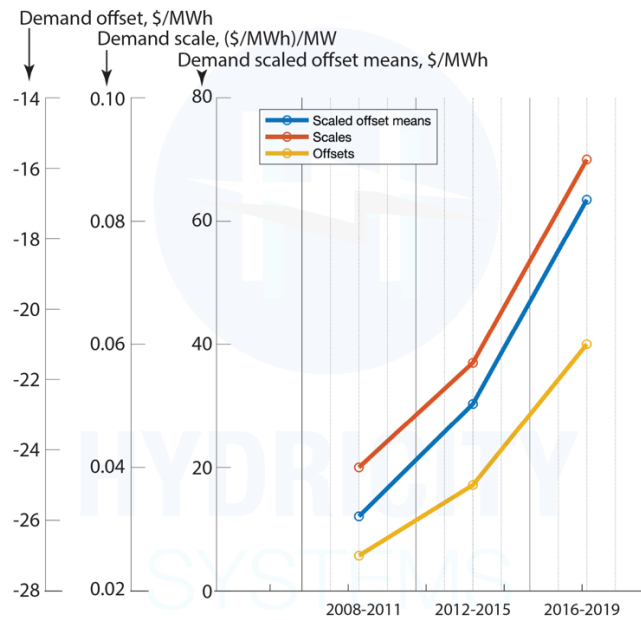

Fig 3.3 Numerics of the three demand price relationships in Fig 3.2

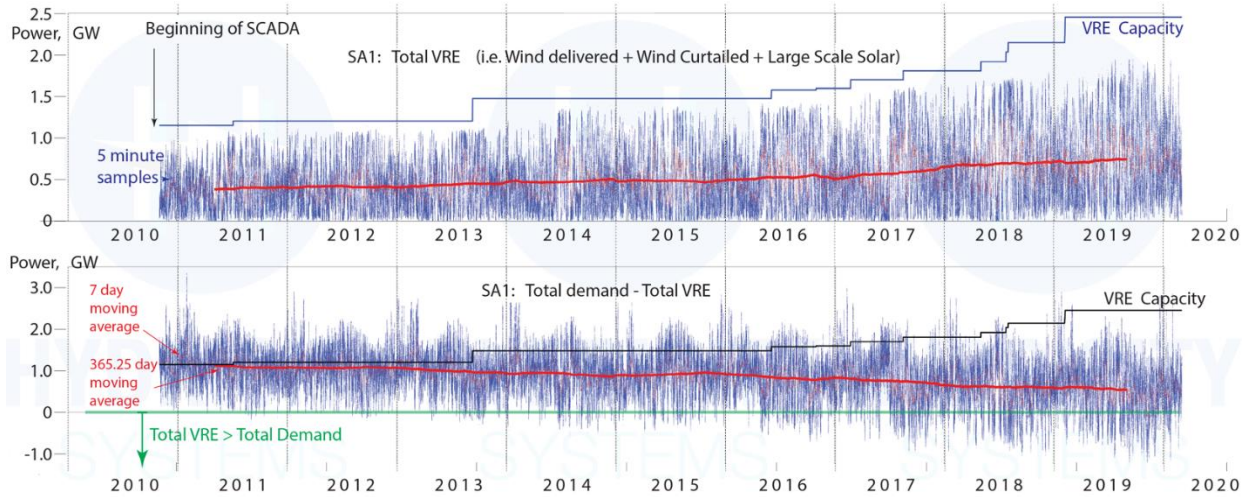

Fig 3.4 Profiles of the increasing production over a decade in the SA Region of Australia’s NEM

“(Demand - Wind - Curtailment - Solar)* duration / average price curves” for SA;
with % VRE Production / Demand. All plots graphically clipped to below average scaled offset *dmwcs

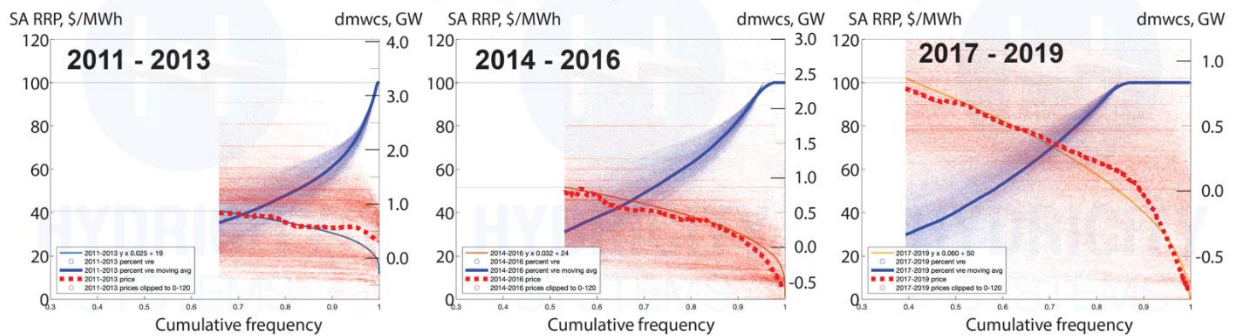

Fig 3.5 Profiles of the effect of VRE on prices in the SA Region of Australia’s NEM

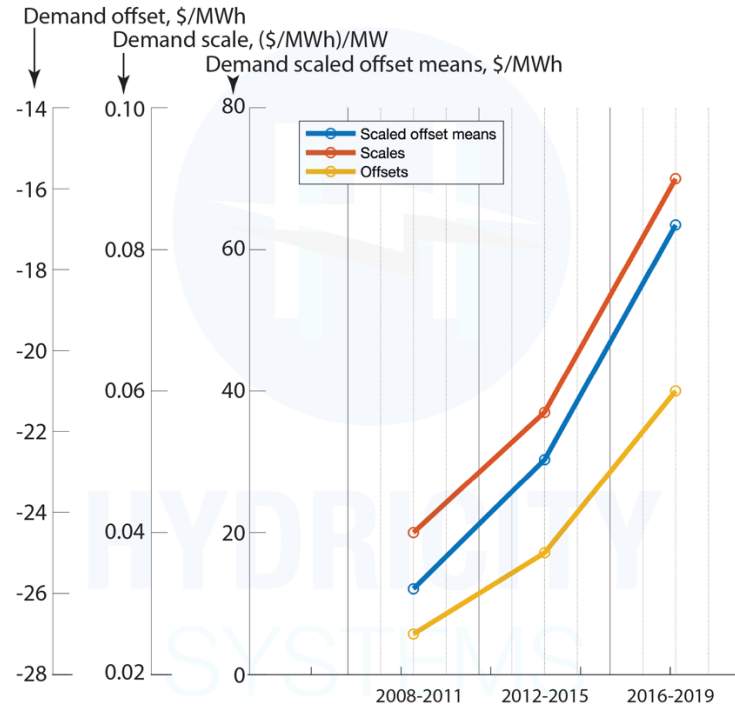

Fig 3.6 Numerics of the three demand - VRE price relationships in Fig 3.4

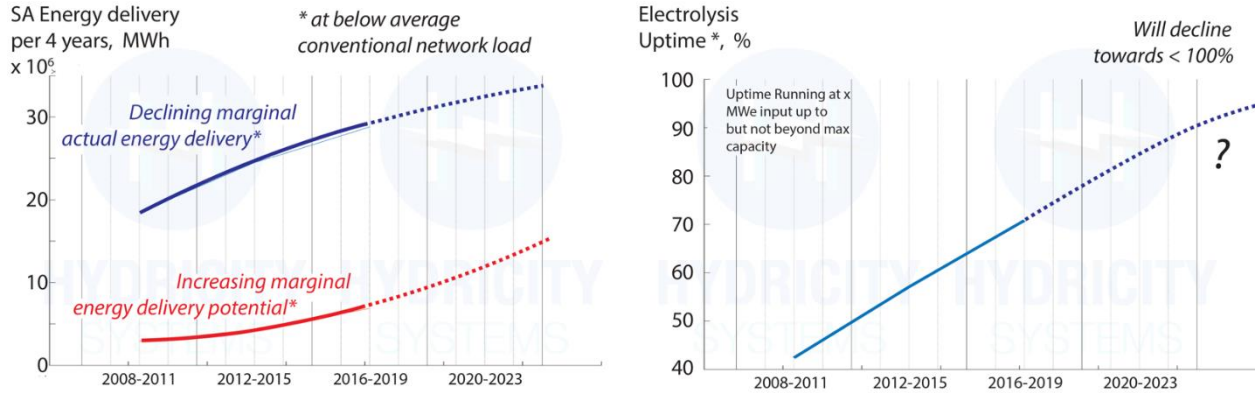

Fig 3.7 Broad predictions of increasing electrolysis uptime resulting in ongoing increases in VRE production

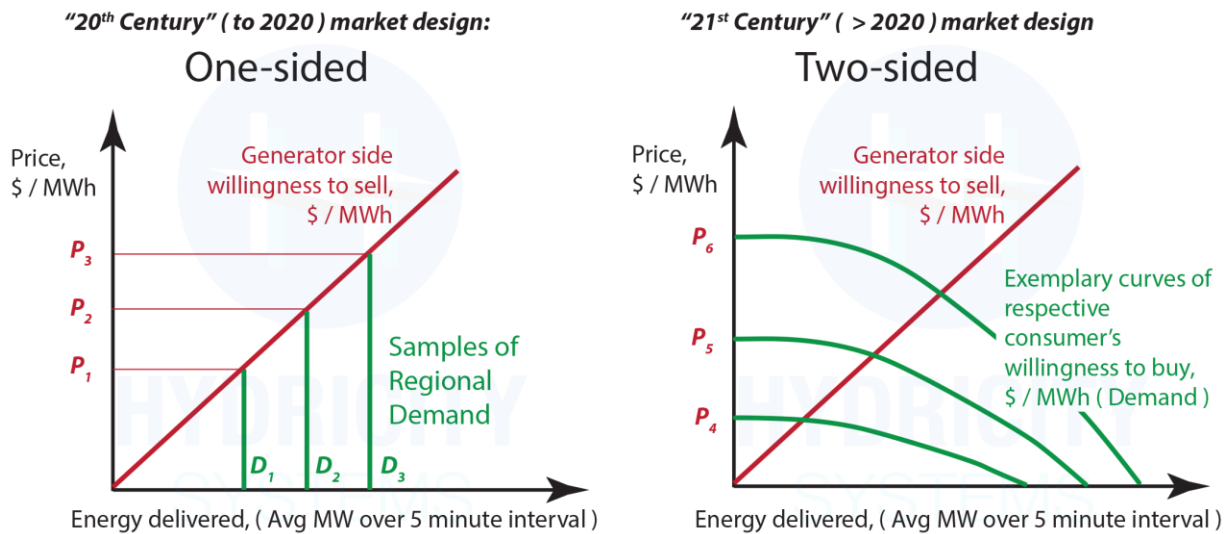

Fig 3.8 Electricity, Demand, and Supply: Current, (left), and proposed two way market design (right)

[Adapted from Figure 30 "Benefits of participation from price elastic demand and supply" of [1]]Quoting from page 91 of [1]:

“The two-sided market work specifically promotes the effective uptake and utilization of DER and demand response by:

Establishing a framework for the trading of ‘services’ in the market as opposed to asset-level obligations and performance requirements – supporting higher levels of flexible capacity and facilitating innovation in services for consumers.

Evolving the market design to provide spot price signals that enable flexible two-way supply and demand resources to engage at all connection points.

Simplifying the participation framework to support traders of services to aggregate connection points (including those with installed DER) to provide services and participate in energy and ancillary service markets, where they meet the service specifications.”

In conclusion, the techno-economics modeling of the input-electricity cost of emerging participation of power to hydrogen can be founded quite simply on bottom-up purchase-price bidding in consumption price markets every 5 minutes.

This is independent of the following electricity system security markets (markets for ancillary services). All other concepts that are otherwise described as “generic energy balancing services to the grid” fall into the above electricity energy commodity trading framework in a very natural way.

Electricity system security markets (ESSM / Markets for ancillary services)

In contrast to frameworks reviewed in previous section, system security markets are needed to provide products and services that keep the crucial parameters of electricity network within ranges requires to “keep the lights on”. By “keeping the lights on” we’re not referring to the ongoing availability of generation. Rather we’re referring keeping the system as a whole up and running despite the risk of instantaneous failures of major components such as transmission lines collapsing under the weight of an ice-storm or sudden down-burst storms, or the unexpected unplanned dropout of a large-scale generator, and so on. ESSM in general is about much more than just frequency control in particular, but this particular power systems parameter provides a useful starting point for distinguishing between between EECT and ESSM, as graphically outlined in Fig. 3.9.

Electricity system security markets for, for example, frequency control

Energy commodity markets: "Production and consumption", "Supply and demand" including emerging two-way markets (generation and load bidding)

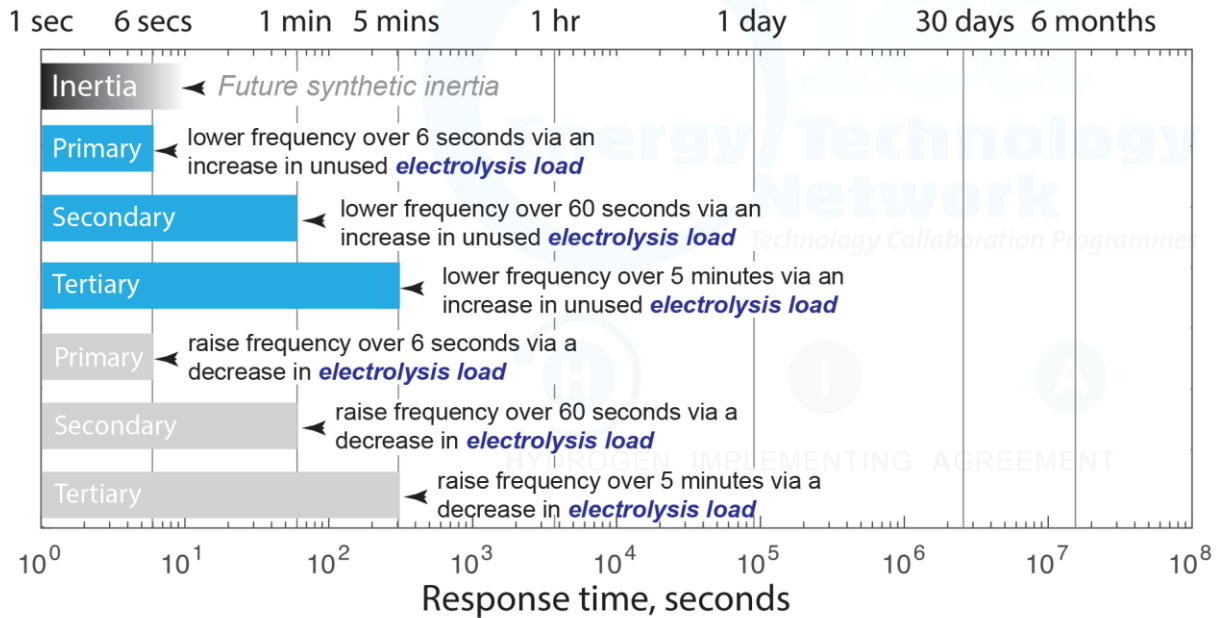

Fig 3.9 Prospective participation of power to hydrogen in frequency control system security markets

Note that Figures 3.1 and 3.10 allude exclusively to prospective technical participation in respective EECT and ESSM markets: there is no reference to the prospective market value of such participation. To set the stage for the prospective revenues from participation in ESSM markets over and above participation in two-way commodity trading markets, consider the example of the "world's largest battery" (at its time of initial deployment): the 100 MW input capacity system supplied by Telsa to the Neoen's Hordsdale Power Reserve in South Australia.

Consider the 5 min resolution buy and sell profiles EECT (conventional energy commodity trading) of this facility, along with the 7-day (2016 sample) moving averages, presented in Fig 3.9. Clearly this facility operated in this way is not financially substantial in and of its EECT market participation. Instead, by continuously being available for ESSM markets, specifically, frequency control ancillary services (FCAS), the capital cost of this facility has been paid off in record time relative to the original budget, as presented in Fig. 3.10 - 3.13.

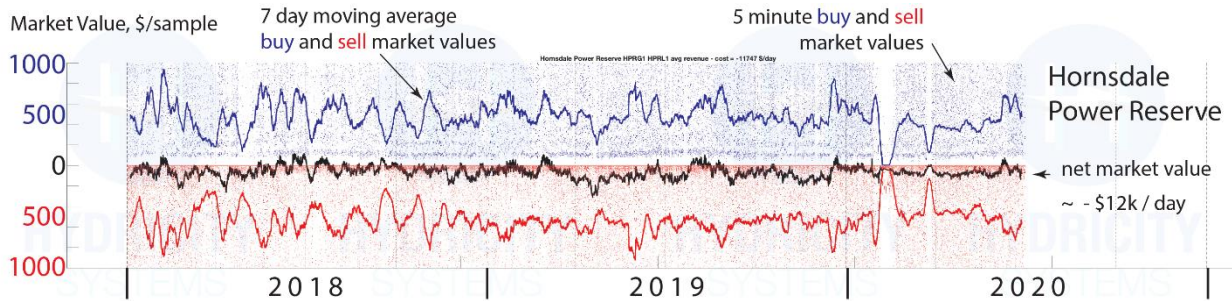

Fig 3.10. Energy commodity buy and sell market value sample time-series for Hornsdale Power Reserve

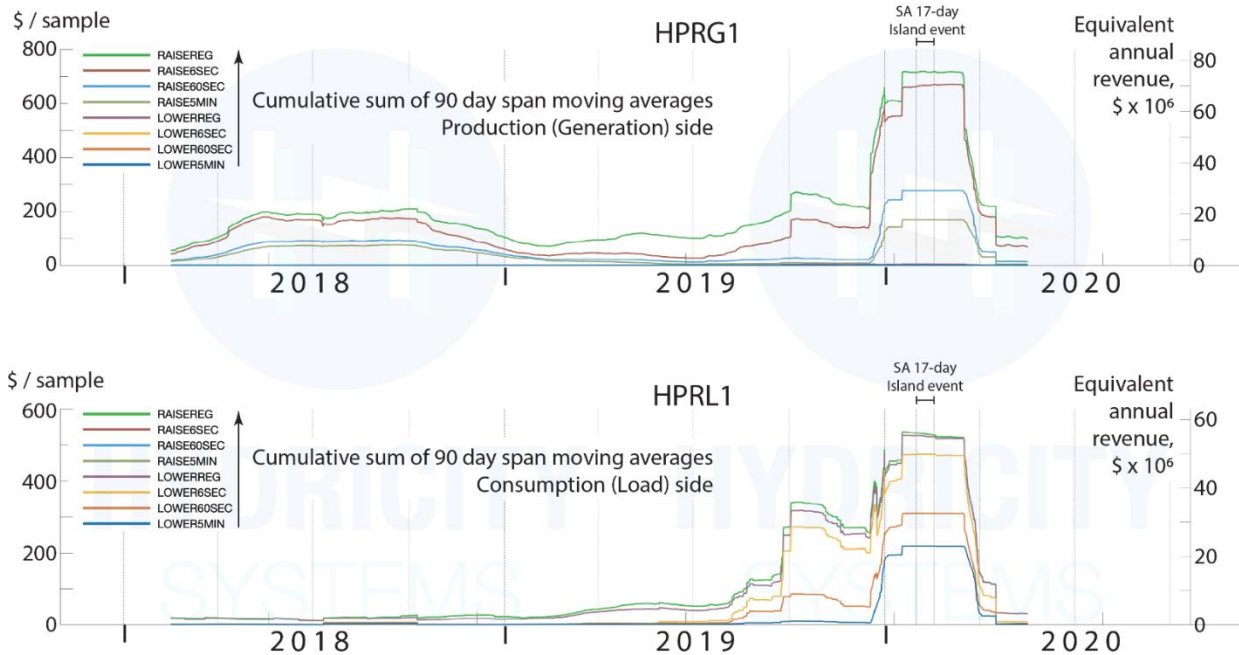

Fig 3.11 Summed 90-day averages of 8 x 2 FCAS market value sample time-series for Hornsdale Power Reserve

Hornsedale Power Reserve FCAS “normal” revenue statistics: excluding period from 31 January to 16 Feb 2020

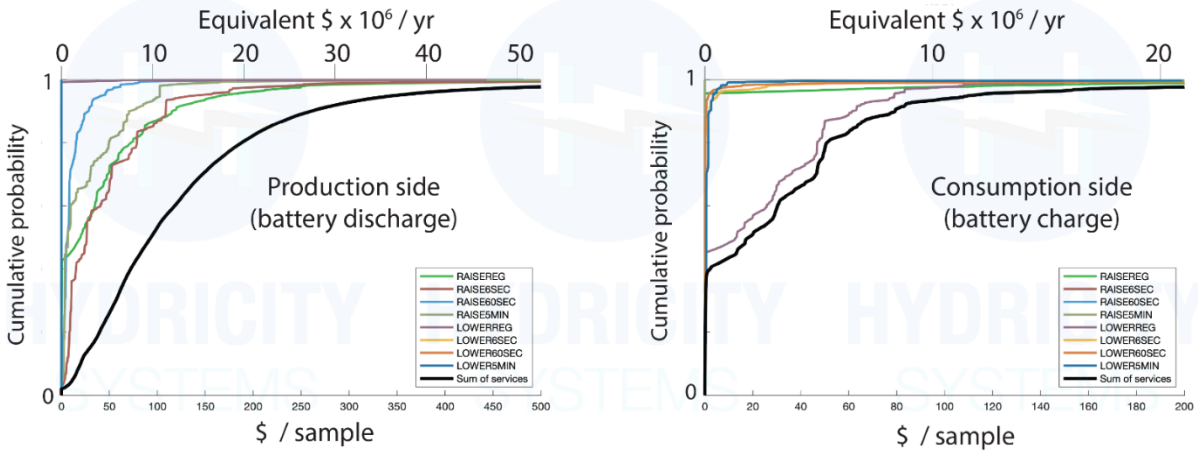

Fig 3.12 Empirical cumulative probability distributions for HPR, excluding 17 days from 31 Jan 2020

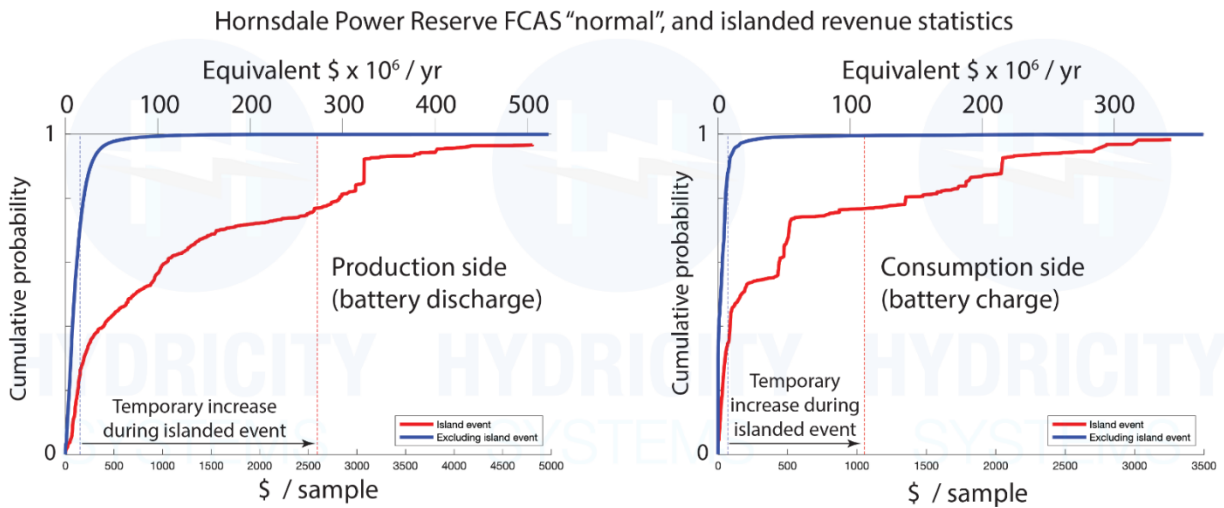

Fig 3.13 Empirical cumulative probability distributions for HPR, “normal”, and “islanded”.

The very large marginal revenue in January 2020 was the result of a convective downburst in the adjacent Region of Victoria which downed a major transmission line, resulting in the operation of the South Australia Region of the NEM as an island for 17 days starting 31 January 2020. As a result, the lights stayed on for the entirety of this event despite SA being dominated by inverter-based resources (IBR), including periods of 100% IBR.

Nevertheless, the function of the FCAS *market* was stretched well beyond its normal limits, highlighting the need for not only technical design considerations being paramount to managing the evolution towards higher VRE proportions, but also, market design considerations [2].

In summary, while the security technical and market designs are expected to continue to evolve quickly in the coming years, the balance might well be in favour of accounting for the value of electrolysis participation in security markets (ESSM) over and above conventional energy trading (EECT). In turn, this suggests that those who model the viability of power to hydrogen in terms of just electricity purchases, hydrogen selling, and capital write down, are potentially missing a crucial future contributor to the viability of power to hydrogen.

Summary of potential roles for power to hydrogen

At the time of writing, the required time and resources had yet to be allocated to assessing which physical parameters of the electricity system might be open to the prospect of power to hydrogen participation.

Frequency control (FCAS) is clearly one such prospect and is potentially the most important in terms of revenue potential. That is, some PEM electrolyser manufacturers demonstrated a while back that their hardware and software is capable of responding at speeds comparable to those in which the above large-scale batteries operate. Nevertheless, we do not present quantitative data in this report.

Beyond the scope of FCAS, going forwards to (for example, IEA Hydrogen Task 41), it will be crucial to adopt agreed terminology – terms that can be used across the relevant disciplines, as follows:

The *security* of the power system refers to its ability to remain stable in response to disturbances.

In turn, **stability** refers to the limit of variation of system parameters within specific ranges (such as frequency, phase angle, voltage, active and reactive power). e.g. Frequency of 50Hz +/- **tol**, where if the frequency exceeds **tol** above or below 50 then fast responding action is required to bring the system back to “stable”.

In turn, for frequency control, in many regions **fast responding actions** are called Frequency Control Ancillary Services (FCAS).

Reliability is distinct from security and stability ... (but is not defined in this paper)

Synchronous mechanical rotating turbines are directly connected and are synchronized with the grid, rotating with the same speed and delivering electricity at the same phase angle.

Asynchronous generators have no rotating mass and connect to the grid via power electronic inverters.

Inverters convert Direct Current (DC) electricity into grid-compatible Alternating Current (AC) delivering in-phase electricity at the grid’s frequency.

An **inverter based resource** (IBR) is any DC power generation technology that uses an inverter to connect to the electricity grid.

Variable Renewable Energy (VRE) refers to production that is intermittent. VRE in MW(t) varies with respect to time t, independently of grid demand (consumption) and other system parameter variations. This includes both production-consumption balancing time scales (> 5 minutes), and system security time scales (In Aus NEM FCAS: <= 5 minutes, <= 60 second and <= 6 seconds).

Inertia: the **spinning mass** of rotating turbines have a continuous store of kinetic energy. If a turbine’s energy source flow fails, this kinetics enables rotating turbines to deliver a smoothed out impact on the grid. In lieu of an impulse (step-change) to grid parameters, such a failure imposes a steady but slowly decaying impact over a period of time.

Fault current: On the occurrence of a fault, *synchronous resources* inject high levels of current into the fault, thereby limiting the rate of voltage degradation.

Similarly, it is crucial that cross discipline agreement is achieved in accepted that the risk of failure can at best be mitigated, but not eliminated. In turn this leads to the need for several parallel processes such as [2]:

- limit the risk and magnitude of those imbalances to within the operational tolerances of the system.
- ensure that there are sufficient emergency mechanisms to mitigate impacts when the tolerances are breached.
- recover the system effectively and expeditiously when there is an interruption to service.
- ensure that the inevitable interactions between different aspects of security are manageable

For ongoing assessment of the potential for power to hydrogen to participate in security markets, it will also be crucial going forwards to understand both past and prospective future mechanisms (e.g. [2]) and how they might differ. Both market and non-market mechanisms are enumerated in Table 1, but it seems likely that the opportunities for power to hydrogen will lie primarily in market mechanisms.

Table 1 Market and non-market mechanisms for supplying system security

(Adpated from Figure 11 of [2])

Mechanism	Description	Examples
<i>License conditions</i>	Mandatory conditions imposed on network access to provide or contract system services	Virtual inertia (Québec and Ontario, Canada) Primary frequency control (Australia’s National Electricity Market (NEM), North American Electric Reliability Corporation (NERC), UK’s National Grid) Mandatory reserves (Spain) Do-no-harm conditions imposed on generator (Australia NEM) Conditions imposed to supply reactive power services (UK’s National Grid)
<i>Regulatory obligations</i>	Regulatory obligations on transmission network owners to provide system services	Obligation to support of a minimum system strength (Australia’s NEM) Obligation to contribute to a minimum inertia (Australia’s NEM)
<i>Regulatory delegations</i>	Regulated delegations to supply services via contracting or auctions	Delegation schemes for supplying system integrity protection (Australia’s NEM) Delegation markets for control ancillary services (Australia’s NEM) Stability auctions (UK’s National Grid) Enhanced frequency response (UK’s National Grid) Enhanced reactive power services (UK’s National Grid) System services tender (Ireland)

		MVaR services tender (Belgium)
<i>Spot markets</i>	Market for supplying system services under an operational-ahead or real-time timeframe	<p>Fast regulation markets (North East US's PJM, US and Canada's Midcontinent Independent System Operator (MISO))</p> <p>Ramping products (California Independent System Operator (CAISO), mid-continent's MISO)</p> <p>Primary frequency reserve (proposed for Australia's Wholesale Electricity Market (WEM), Finland's Fingrid)</p>
<i>Constraints and interventions</i>	Operator intervention or the imposition of technical constraints on operational dispatch to maintain system security	<p>Security-based constraints on unit commitment and otherwise exclusively market-based dispatch</p> <p>Residual unit commitment</p> <p>Market intervention: security-based direction</p>

In conclusion: The physical characteristics of electricity system security are complex and multifaceted, with many facets interacting with each other. Regardless of the evolving and emerging details market and non-market methods for supplying system security, there is clear potential value in having grid-connected power-to-hydrogen infrastructure participate in **both** :

- 1) Two way electrical energy commodity trading (EECT)
- 2) Electricity system security markets (ESSM)

An assessment of the physics of electrolysis hardware in this context will deliver crucial foundation to future assessments of the additional value of ESSM participation to power to hydrogen, over and above EECT participation.

For readers seeking more detail, the following section provides a more comprehensive review.

A more detailed review of key global market and non-market security mechanisms

Participation requirements in electricity markets varies considerably regarding the service, availability, pricing, location, auction times, and clearing time and payment schemes, size of asset and/or system requirements; additionally, the varying logistics and participation rules in differing geography zones can often render energy storage project economics and logistics complex. Today, larger consumers economically benefit from optimizing their consumption via participation in balancing services like demand response (real time energy balancing), avoiding demand charges at times of peak consumption and high electricity prices, and even arbitrage with markets with a large variation of daily electricity prices. Other new technologies target frequency regulation markets and capacity markets to seek appropriate remuneration for large-scale energy storage projects, which still possess costly investments. One of the most important technical parameters for frequency-related ancillary services are the reaction times and ramping rates to limit deviations in the frequency. As electrolyzer technologies advance and increase in efficiency and reaction and skew times, they could prove to be valuable assets in an electric power network due to their range of flexible operation. Despite the technical capabilities, the economics and market participation size remain obstacles for investors to justify deploying energy storage projects and other new technologies for services to the grid. Adjusting electrolyzer operation in response to grid signals suggests to strategically lower hydrogen production, suggesting that the costs must be spread over less revenue from the sale of hydrogen. Additionally, flexible operation may affect the overall lifetime of the power to gas system; limiting project lifetimes which increases the levelized cost of hydrogen and availability to participate in services to the grid. Despite the current economic barriers, electrolyzer technologies have the technical ability to respond to several services to the grid – whether for ancillary services for the system operator or in energy balancing to ameliorate the operation and electric landscape. Power to gas systems, when combining the hydrogen production chain (for mobility, chemical industry, or even re-electrification via fuel cells) with services to the grid may prove to be a relevant solution in the future [3].

1. Definitions and technical requirements of ancillary services (focus on frequency regulation) in several electricity markets

Definitions relevant to services to the grid (using European Network of Transmission System Operators for Electricity terms) [4]:

- **Ancillary services:** Ancillary services refers to a range of functions which Transmission System Operators (TSOs) contract to guarantee system security. These generally include black start capability (the ability to restart a grid following a blackout); frequency response (to maintain system frequency with automatic and very fast responses); and fast reserve (which can provide additional energy when needed); the provision of reactive power and various other services. An important aspect of balancing is the approach to procuring ancillary services. These services generally adhere to the needs of the system operator in order to have an operational electric power network.
- **Frequency control (response and reserves):** The grid requires access to sources of additional power in the form of either generation or demand reduction, to be able to deal with unforeseen fluctuations in the alternating current frequency which occurs due to imbalances in supply and demand (e.g. loss of a generator, losses in variable renewable energy sources, etc.). These additional sources of power available are referred to as “reserves” and are comprised of synchronised and non-synchronised sources. Different sources require different timescales in order to deliver frequency control. In general, there are typically three types of services to contain, restore, and ensure frequency control of an electric power network – these are generally separated into what are referred to as primary, secondary, tertiary and/or reserves, which respectively take place when imbalances or generator losses occur within the network. Figure 29 displays an event (i.e. loss of a generator) which requires frequency control services to restore the frequency to operational levels (generally within a few hertz):

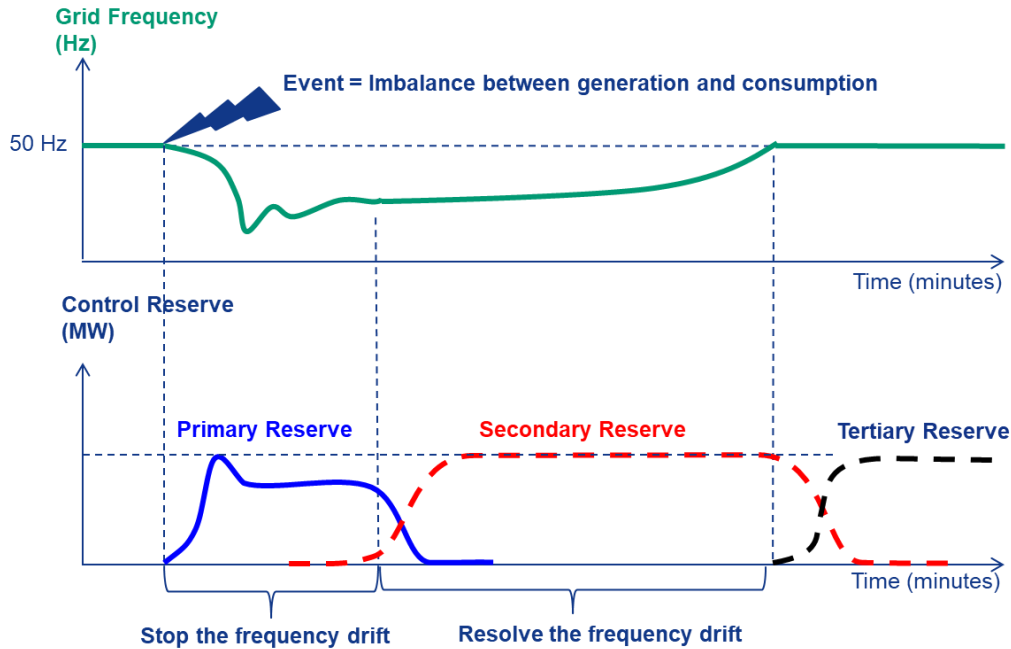

Figure 29. Frequency control diagram of reserve responding to an event

As seen in Figure 29, primary frequency control limits and contains large frequency deviations, secondary control restores the frequency back to its target value, and the tertiary and/or reserves react later (and even manually) for longer durations to keep this imbalance from recurring, ensuring the restoration of a stable frequency. In Europe, these services are separated and denoted as follows:

- Frequency Containment Reserve (FCR): Primary reserve (included in the ancillary services) – European ENTSO-E nomenclature (see Figure 32 for different names of frequency regulation services for differing electric power networks)
 - aFRR - automatic Frequency Restoration Reserve: Secondary reserve (included in the ancillary services)
 - mFRR- manual Frequency Restoration Reserve: Manual reserve with a mobilization time shorter than 15 minutes (fast reserve, included in the ancillary services)
 - RR - Replacement Reserve: Manual reserve with a mobilization time longer than 15-minutes (complementary reserve and other, included in the balancing services and reserve and response services)
- **Reactive Power Services:** Reactive Power describes the background energy movement in an Alternating Current (AC) system arising from the production of electric and magnetic fields. Devices which store energy by virtue of a magnetic field produced by a flow of current are said to absorb reactive power; those which store energy by virtue of electric fields are said to generate

reactive power. The flows of reactive power on the system will affect voltage levels. Unlike system frequency, which is consistent across the network, several voltages may be experienced at points across the system form a 'voltage profile', which is uniquely related to the prevailing real and reactive power supply and demand. The Grid must manage voltage levels on a local level to meet the varying needs of the system. Without the appropriate injections of reactive power at correct locations, the voltage profile of the transmission system will exceed statutory planning and operational limits.

- **Spinning and non-spinning reserves:** A generating unit already connected to the network and able to supply additional power rapidly. Essentially the unused capacity which can be activated on decision of the system operator and which is provided by devices which are synchronized to the network and able to affect the active power. This can refer to the secondary reserve as well as the tertiary. The term spinning reserve is generally in contrast with non-spinning reserves, suggesting the asset is not connected or synchronized to the network, but can be brought online in order to respond to restore the frequency to operational levels. (e.g. in California non-spinning reserves should be online within 10 minutes of notification and provide power to restore frequency for 2 hours).
- **Fast response:** Fast reserves provide the rapid and reliable delivery of active power through an increased output from generation or a reduction in consumption from demand sources, following receipt of an electronic dispatch instruction from TSO. Fast Reserve is used, in addition to other energy balancing services, to control frequency changes that might arise from sudden, and sometimes unpredictable, changes in generation or demand. The quicker the response, the smaller the deviation, suggesting that the total market size (MW) to respond to imbalances with fast response assets is less than if responding with slower responding assets – as the frequency deviation will be larger with increasing time and require more power for containment and restoration.

The main interest for new storage technologies which have the ability to respond quickly to events and instructions generally include frequency control (regulation, reserves, etc.) as well as the ability to consume in a flexible manner. The activation time as well as discharge duration are of importance in determining which grid services are suitable when determining the most appropriate technologies. Recently, energy storage technologies like batteries, flywheels, super/ultracapacitors, and power to gas technologies are able to smooth and stabilize variable renewable energies (VRES), react quickly to signals and changes in the electric power networks, as well as provide energy for longer-term capacity needs within electric power networks. The interest of newer energy storage technologies lies in their ability to function both as a generator and consumer in addition to storing electricity. In this sense, power to gas systems can operate both in the interest of producing hydrogen for the chemical, industrial, or mobility sectors, and adjust their operation to additionally function as an asset to the system operators who manage electric power networks. This concept has been addressed in several demonstrations previously completed and suggests that utilizing the flexibility of electrolyzers (which can operate under

varying loads) to provide services to the grid to account for fluctuations is a technical reality. Thus, ancillary services (i.e. frequency regulation and reserves) and energy balancing (i.e. load shifting for renewables and/or demand management) have been identified as the most appropriate services to the grid in which electrolyzers and power to gas systems may contribute. Below, Figure 30 visually portrays the concept of frequency control (using the three reserves discussed previously) as well as the relative time scale regarding reaction and duration times to respond to frequency deviations – which is generally defined by national policies. Figure 31 Note that these figures use the European Network of Transmission System Operators for Electricity (ENTSO-E) terms and abbreviations.

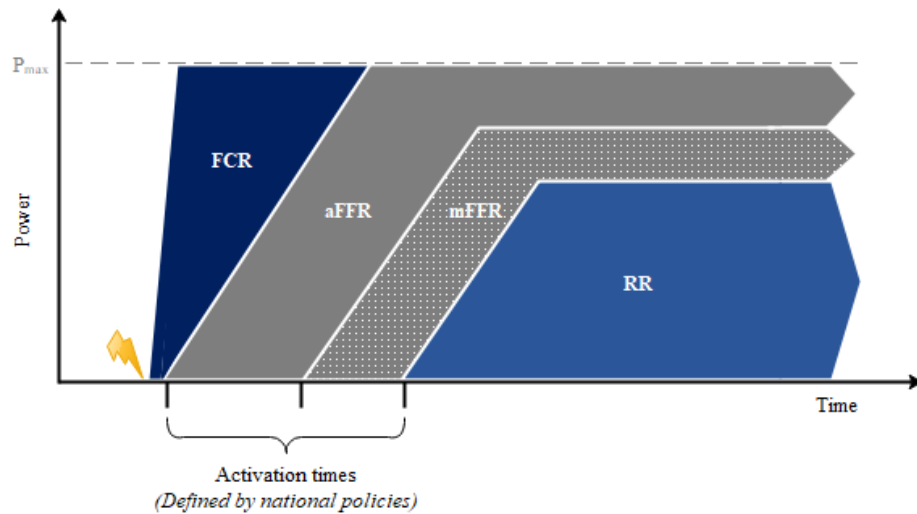

Figure 30. Frequency control service reserves (using ENTSO-E nomenclature)

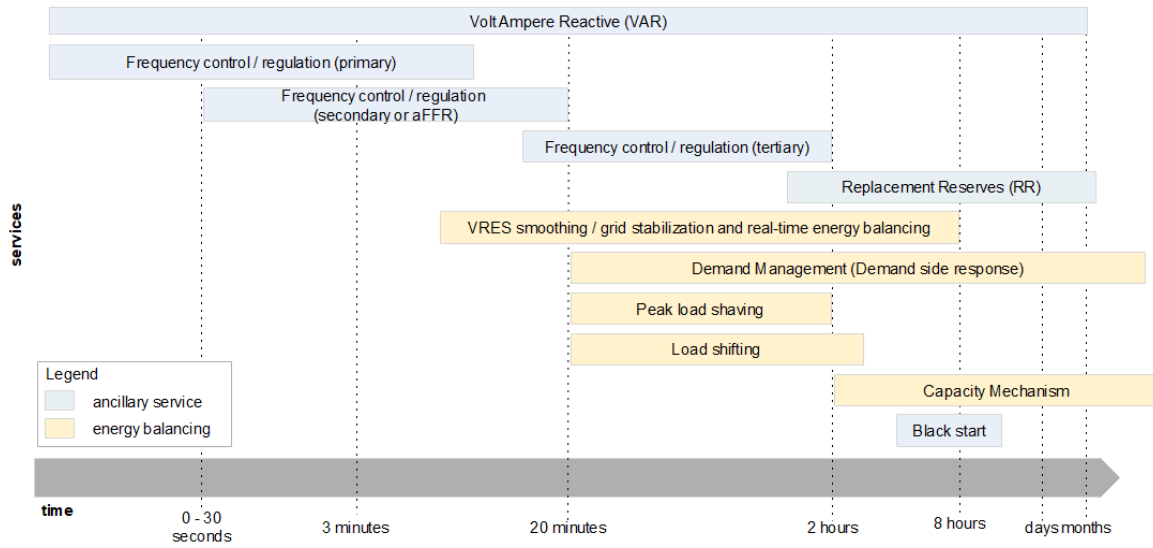

Figure 31. Example of time scale for ancillary services and energy balancing in electricity markets

Though the same rules and regulations do not apply to all electric power networks, the general concepts and services are the same. Electric grid service requirements in different zones vary in response time (including ramping and time to provide full power), duration time, as well as minimum size for participation, market size, remuneration structure, as well as average prices and potential revenues possible. Some markets are more established than others, which may facilitate participation requirements and entry points for power to gas systems as newer technologies as their beneficial characteristics are increasingly understood. Every electric power network has certain services which are more lucrative than others, economically; nevertheless, newer technologies generally have difficulties in deploying these costly solutions.

Below, Figure 32 displays some of the designated names for frequency control reserves in different established electric power networks across the world. This gives an idea of the various markets and frequency reserves to which power to gas systems could participate, technically. *Note that the ENTSO-E network, which is synchronized between several western and central European countries (Austria, Belgium, France, Germany, Netherlands, and Switzerland) has common names for the primary, secondary, and tertiary frequency control (i.e. FCR, aFRR, and mFRR).*

Primary frequency control reserves	Secondary frequency control reserves	Tertiary frequency control reserves
------------------------------------	--------------------------------------	-------------------------------------





ENTSO-E <i>(several European countries)*</i>	Frequency containment reserve (FCR)		Frequency restoration reserve – <i>automatic</i> (aFRR)	Frequency restoration reserve – <i>manual</i> (mFRR) (followed by Replacement reserve (RR))	
France*	Réserve primaire		Réserve secondaire	Reserve tertiary	
				Réserve tertiaire rapide 15 minutes	Réserve tertiaire complémentaire 30 minutes
Belgium*	Réserve de puissance pour réglage primaire		Réserve de puissance pour réglage secondaire	Réserve de puissance pour réglage secondaire	
Germany*	Primärregelreserve		Sekundärregel-reserve	Minutenreserve	
Netherlands*	Primaire reserve		Secondaire reserve	Tertiaire reserve	
USA <i>(PJM)</i>	Inertia Response / Regulation (mandatory)	Operating reserves			System Re-dispatch (SCED)
		Contingency Reserve		Supplemental Reserve	
		Synchronized (Spinning) Reserves	Quick-Start Reserves	Synchronized and Non-synchronized reserve	
USA <i>(CAISO)</i>	(no given name)		Operating Reserve		Replacement reserve and supplemental energy
			Regulating reserve	Contingency reserve	
			Spinning reserve	Non-spinning reserve	
United Kingdom <i>(Great Britain, Wales, and Scotland)</i>	Dynamic Response			Dynamic & Non-Dynamic Services	
	Primary Frequency Response (< 10 seconds)		Secondary Frequency (< 30 seconds)		Balancing Mechanism and STOR
	Enhanced Frequency	Primary and High Firm Frequency Response (FFR)	Secondary Firm Frequency Response (FFR)		

Task 38 Final Report - September 2020

	Response (EFR)			
	(< 1 second)	Dynamic	Dynamic	
Sweden	Frekvensstyrd Normaldriftsreserve and Störingsreserv		(does not exist)	Seven different types of reserves
Czech Republic	Pervitchnyi reserve		Vtoritchnyi reserve	Tretitchnyi reserve
Australia	Contingency services		Regulating services and network loading control	Short-term capacity reserve
	Fast	Slow	Delayed	
New Zealand	Instantaneous reserves		Frequency regulating (or keeping) reserve	(no given name)
	Fast	Sustained		
	Over frequency			

Figure 32. Table of names for different frequency regulation services in different countries and electric power networks

To give an idea of minimum size required to participate in different electricity markets, as well as reaction time, and duration, market size, and remuneration possible (pricing generally for 2017 – 2018 year), Figure 33 below summarizes some of the technical capabilities when addressing the European transmission grid as described the Fuel Cell and Hydrogen Joint Undertaking (FCH JU) [5]. Following this, several tables of information (Figure 34, Figure 35, and Figure 36) summarize the frequency regulation market services for three different European networks, including the respective frequency service names and specific rules of participation. Though there may be no specific mention of power to gas or electrolyzer technologies in these rules and regulations; overall, it seems that power to gas systems are technically capable of providing services to the grid and can provide flexible grid assets.

	Frequency Containment Reserve (FCR)	Frequency Restoration Reserve (FRR)	Replacement Reserve (RR)
Definition	 FCR automatically and continuously regulates the positive and negative frequency fluctuations; electrolyzers can support the system via increased/decreased demand	FRR can automatically or manually restore the frequency via operating reserves to replace FCR; electrolyzers can support the system via increased/decreased demand	RR is used to restore the required level of operating reserves; supersedes FCR and FRR to be prepared for further disturbances in the grid
Suitable electrolyser technology²⁾	 PEM / Alkaline (until now, only tested under lab conditions)	PEM / Alkaline (when operated adequately)	PEM / Alkaline
Requirements	 Activation time ≤ 30 s; utilisation for 15 min max; minimum bid size ± 1 MW; 1 week commitment per auction	Activation time 2-15 min depending on country-specific regulations; no standardized technical requirements	Activation time (≥ 15 min) depending on country-specific regulations; no standardized technical requirements
Procurement	 FCR activation is a joint action of all TSOs in Continental Europe; quite homogeneous technical requirements; joint procurement in Central Europe via auctions organised by TSOs	Fragmented regulation across the European Union; procurement via auctions organised by TSOs in various European countries	Fragmented regulation across the European Union; procurement via auctions organised by TSOs in various European countries

Activation time; operating time

Figure 33. FCH hydrogen participation in frequency control in Europe [6]

Grid	System Operator(s)	Countries	Frequency Regulation						
			Type	Name	Minimum Size (MW)	Response Time (min)	Duration (min)	Average pricing (€/MW/h)	Market Size (MW) ¹
ENTSO-E	<ul style="list-style-type: none"> ▪ APG ▪ Elia ▪ 50Hertz ▪ Amprion ▪ TenneT (NL and DE) ▪ TransnetBW ▪ RTE ▪ Swissgrid 	<ul style="list-style-type: none"> ▪ Austria ▪ Belgium, ▪ France ▪ Germany ▪ Netherlands ▪ Switzerland 	Primary	Frequency Containment Reserve (FCR)	1	0.5	15 – 30	≈ 15	3000
			Secondary	Frequency Restoration Reserve (aFRR) automatic	1	0.5 – 15	Duration of the service is not detailed	Varies (0–50)	6000
			Tertiary	Frequency Restoration Reserve (mFRR) manual / Restoration Reserves (RR)	1	30	Duration of the service is not detailed	Varies (0–50)	3% total capacity

Figure 34. ENTSO-E frequency regulation services

Grid	System Operator(s)	Countries	Frequency Regulation						
			Type	Name	Min. Size (MW)	Response Time (min)	Duration (min)	Average pricing (€/MW/h)	Market Size (MW)
National Grid (UK)	National Grid	<ul style="list-style-type: none"> United Kingdom (Scotland, Great Britain, Wales) 	Synthetic Inertia	<i>Enhanced Frequency Regulation (EFR)</i>	1	0.017	0.16	9.4	200
			Primary	<i>Firm Frequency Response (FFR): High Frequency Response</i>	1	0.16	∞	5 – 10	800
				<i>Firm Frequency Response (FFR): Primary Response</i>	1	0.16	0.33	Varies	1200
			Secondary	<i>Firm Frequency Response Reserve (FFR)</i>	1	0.16	30	Varies	400
			Tertiary Reserves /	<i>Short Term Operating Reserve (STOR)</i>	3	240	120	Varies	3000

Figure 35. The United Kingdom frequency regulation services

Grid	System Operator(s)	Countries	Frequency Regulation						
			Type	Name	Minimum Size (MW)	Response Time (min)	Duration (min)	Average pricing (€/MW/h)	Market Size (MW)
Northern European	Svenska Kraftnät (SvK)	Sweden	Primary	<i>Frequency Containment Reserve-Normal (FCR-N)</i>	0.1	63% within 60 secs. and 100% within 3 mins.	Duration of the service is not detailed	39.8 (for 2018) 23.5 (for 2017)	200 MW for Sweden (600 MW for the synchronous Nordic system)
				<i>Frequency Containment Reserve-Disturbance (FCR-D)</i>	0.1	50% within 5 secs. and up to 100% within 30 secs.	Duration of the service is not detailed	N/A	400 MW

			Secondary	<i>Automatic Frequency Restoration Reserve (aFRR) –</i>	5	100% within 120 secs.	Duration of the service is not detailed	N/A	150 MW
			Tertiary / Reserves	<i>Manual Frequency Restoration Reserve (FRR)</i>	10 (5 for the Malmö area)	100% within 15 mins	Duration of the service is not detailed	N/A	N/A

Figure 36. Northern European grid frequency regulation services

Outside of Europe, the United States and Australia consider frequency control in terms of typical deviations during normal operation, and then in the event of a contingency (a large loss). This makes it difficult to compare the different services pertaining to frequency regulation between different market structures, but essentially the concept remains similar. Additionally, most of the products for regulation in Europe are symmetric, suggesting that assets can consume or generate to aid in stabilizing or restoring the frequency as needed. Some markets have asymmetric products for ancillary services, allowing assets to contribute to only increase or decrease in consumption. This is important for electrolyzers, as remuneration for increase (up or raise), as well as decrease (down or lower), are not equivalent and affect the operational efficiency of hydrogen production – greatly affecting the economics of power to gas grid connected projects.

Services to the grid all have their purposes, though the terminology can be confusing, as Australia’s “reserves” designates investments in generation capacity and not frequency control reserves. In the United States, the Operating Reserves refer to real-time corrections in imbalances (like frequency regulation and demand response), whereas planning reserves refer to capacity adequacy for longer time energy procurement. It is difficult to characterize non-European frequency control services by primary, secondary, and tertiary services, as each operator chooses their method(s) in the case of events or imbalances to best manage their electric network. Below the table referring to PJM (the Pennsylvania Jersey Maryland network in the USA) suggests that the frequency control service providing market opportunities lies mainly within the secondary regulation. When comparing with the European definition of primary, secondary, and tertiary, this concept is difficult to compare due to market structure and method of containing the frequency; nevertheless, this frequency service has been categorized within the primary for simplification – as inertial response is generally mandatory (and thus not remunerated) for large generators in many electric power networks; followed by synchronized (online spinning reserves)

and quick-start reserves (which technically compare more to secondary regulation when comparing with ENSTO-E terminology). Mandatory frequency regulation requirements for large generators may be procured by agreements and outsourced – suggesting there is much flexibility in securing sufficient capacity and technically responding to imbalance solutions in different electricity markets [7].

Grid	System Operator	Country (States)	Frequency Regulation							
			Type	Name	Min. Size (MW)	Response Time (min)	Duration (min)	Average pricing (€/MW/h)	Market Size (MW)	
PJM (USA)	PJM Interconnection	<ul style="list-style-type: none"> United States (Delaware, Illinois, Indiana, Kentucky, Maryland, Michigan, New Jersey, North Carolina, Ohio, Pennsylvania, Tennessee, Virginia, West Virginia, and the District of Columbia (D.C.)) 	"Primary" (Regulation)	Inertial Response (Frequency Response)		0.1	0 – 0.1	Duration of the service is not detailed	N/A	500 - 800
				(part of Operating Reserves)	Primary Control	Synchronized (Spinning) Reserves	0.1	0.1 – 1	Duration of the service is not detailed	6 – 50
			Quick-Start Reserves							
			"Secondary" (Operating Reserves)	Secondary Control (AGC)	Synchronized (Spinning) and Non-Synchronized Reserves	0.1	1 – 10	(Synchronized 1-hour typically)	1	500
"Tertiary"	System Re-Dispatch		0.1	10 - 30	Duration of the service is not detailed	N/A	N/A			

Figure 37. United States PJM frequency regulation services

Grid	System Operator(s)	Country (States)	Frequency Regulation – Frequency Control and Ancillary Services (FCAS)							
			Type	Name	Min. Size (MW)	Response Time (min)	Duration (min)	Average pricing (€/MW/h)	Market Size est. (MW)	
National Electricity Market (NEM)	<ul style="list-style-type: none"> ▪ AusNet Services, ElectraNet, Powerlink Queensland, TasNetworks, TransGrid ▪ Australia: Queensland, New South Wales, Victoria, and South Australia 		Regulation	<i>Regulation Raise</i>			continuous		1000 - 10000	160
				<i>Regulation Lower</i>			continuous			150
			Contingency	<i>Fast Raise</i>			0.1	Duration of the services are not detailed		350
				<i>Fast Lower</i>			0.1		100	
				<i>Slow Raise</i>			1		300	
				<i>Slow Lower</i>			1		160	
				<i>Delayed Raise</i>			5		500	
				<i>Delayed Lower</i>			5		300	

Figure 38. Australian NEM frequency regulation services

2. Definition of energy balancing services (focus on demand management)

Beyond services to ensure system stability and security, energy balancing services generally refer to providing energy (as opposed to power for ancillary services). System operators have the responsibility to plan for events as well as to procure enough capacity to provide electricity to its customers despite imbalances in supply and demand. Specifically, generators can provide energy for long periods of time and power to gas technologies have previously been associated with being an alternative for long-term energy storage with its ability to convert, store, and reconvert electricity. Though hydrogen can be used as a source of energy, its production via water electrolysis provides not only a fast-responding flexible asset for ancillary services, but a flexible asset for energy balancing. Hydrogen can store electricity (in its hydrogen chemical form as well as syngas or mixed with natural gas) as well as optimize the way in which helps to correct the short and long occurring imbalances which arise due to unforeseen consumption

events, loss of generator events, and other unexpected events. This study specifically concentrates on energy balancing using electrolyzers for demand management – either at the system operators demand (denoted “dispatchable”) or the customer’s volition to adjust consumption (“non-dispatchable”) based on price signals. Below brief definitions of these concepts are described below.

- **Energy balancing:** Balancing refers to the situation in which a system operator acts to ensure that demand is equal to supply, in and near real-time. Efficient balancing markets ensure the security of supply at the least cost and can potentially deliver environmental benefits by reducing the need for back-up generation.
- **Demand management:** Demand management consists of adjusting consumption or generation based on economic and technical incentives. Generally, a generator or consumer can adjust generation or consumption based on system operator needs or market price signals (time-based rates) to operate in an efficient manner for economic and technical purposes. Demand response (sometimes called demand side response or demand side management, DSM), specifically refers to assets or aggregated assets which react accordingly after being given a signal by the operator to increase consumption or decrease consumption based on the generation profile at certain times. This can be at the utility, industrial, or even residential scale; though is recognized to be more effective at larger scales. This service and programs assist the operator in correcting the unbalance in generation and consumption during certain unforeseen periods (minutes to hours). Demand charge specifically refers to the consumer efforts to avoid consuming at certain peak demand periods where electricity is more expensive and additional costs may be associated with using the transmission and distribution infrastructures at this time. Thus, the consumer may respond to price signals and peak hours by decreasing consumption, or inversely, consuming during periods of low consumption to avoid decreasing consumption from generators (which may be unideal due to economics, planning logistics, or system efficiencies).

Programs dedicated to demand response are relatively new for many electricity markets around the world. Demand response schemes can be a form of capacity mechanism if they are introduced by the State to ensure security of electricity supply. Therefore, in certain areas, demand management is driven by utility programs to better manage their operations, where elsewhere is demand response can participate via wholesale energy markets, which provides different drivers to provide demand management regarding the type of asset and its flexibility. The ability to adjust consumption for large industrial actors is not always an economically justified option; nevertheless, for others, it could potentially aid in deploying projects which have the technical capability and flexibility to adjust operations. Specific programs around the world for dispatchable demand response are listed below in Figure 39 [8].

Country	Demand Response Program(s) or Pilots	Market size
Australia	Several pilots currently being funded by the Australian Renewable Energy Agency (ARENA) in NSW, South Australia, and Victoria	To procure 200 MW by 2020
France	Mécanisme d'effacement	2,500 MW procured for 2019
Germany	Verordnung zu abschaltbaren Lasten – "AbLaV" (Switchable loads and fast disconnectable loads)	1,500 MW each week
Finland	Demand-side response (as part of the Smart Kalasatama demonstration)	≈ 1,000 MW
United Kingdom	Demand side response (DSR)	> 2,200 MW
United States	Demand Response (also known as curtailment service providers (CSPs) for PJM Demand Response Auction Mechanism (DRAM) - procured by several utilities in CAISO network Demand Response (assets and resources) for ISO-NE	7,500 MW PJM >200 MW for CAISO 2,700 MW for ISO-NE

Market Size data sources: Aus [9], France [10], Germany [11], Finland [12], UK [13], US [14] [15]

Figure 39. Demand response program in different electric power networks

Electrolyser and fuel cell technical specifications

As electric power networks transition to newer technologies and methods using state of the art, more efficient, faster responding technologies, power to gas technologies have the ability to react quickly when in standby mode and with ramping rates to respond to imbalances in the grid. Depending on the priorities of hydrogen production and participation to the grid, reaction times for alkaline and PEM technologies

have been stated to range between 1 second to 1 minute. Of course, the ramping and slew rates vary depending on the technology, temperature, pressure, and other factors – which if poorly optimized or operated may have effects on the lifetime of the power to gas system.

The DOE has previously suggested that a 120 kW electrolyser stack at the National Renewable Energy Laboratory (NREL) demonstrated to start and stop in less than 30 seconds as well as a turndown level ratio of 10:1 – reaffirming the concept that electrolysers for water splitting hydrogen production are flexible assets which may help in managing electric power networks.¹ Modelling to understand the beneficial possibilities of power to gas systems in combined with the grid suggest that multiple electrolysers controlled by Front End Controllers (FEC) can enhance overall grid stability by limiting frequency and voltage excursions. Not only can the electrolyser act as a grid balancing or demand side response asset to the grid operator but can also aid in ramping and offsetting variability in variable renewable energy sources like solar and wind – enabling smoothing rendering the injection profiles more predictable and easier to integrate. The results reported from the tests done with a PEM electrolyser suggest start up times of 30 seconds, and response times (when in standby mode) capable of less than 1 second, and the ability to perform in several services to the grid, such as ancillary services (under PJM signals) and demand response [3].

Considerable work has been completed in order to understand the potential cost reductions by providing services to the grid upon adjusting hydrogen production for power to gas systems by the Department of Energy and NREL in the USA. It is thought that a reduction of up to 30% in hydrogen cost is achievable (based on California rates) for the production and delivery of H₂ without large impacts on hydrogen consumers [16]. Simply avoiding or reducing consumption during periods of high demand charge in California can potentially reduce the production cost of H₂ by 6 – 7% [16].

Therefore, as most quick response requires less than 1 second to roughly 10 seconds, if an electrolyser is on standby-mode or in full operation, it theoretically can technically respond to quick response frequency regulation; though is more appropriate in contributing to secondary or tertiary frequency control services in terms of response time and ramping to full power within less than 30 seconds – as this may prolong the lifetime. Nevertheless, upon technical advancements in the field of water electrolysis, this may become possible in the future – regarding response and ramping rates to respond to ultra-fast frequency regulation products like the Enhanced Frequency Regulation (EFR) in the U.K. or 6-second upper or lower in Frequency Control Ancillary Services (FCAS) in Australia. ITM power claims to have electrolysers available in 1 MW modules responds in 1 second self-pressurises to 80 bar [17]. Hydrogenics noted that in the demonstration HyBalance, they are “down to seconds” in response times – suggesting that development within water electrolysis technologies continues to respond to real-time electric power network fast-response products as well as aiding in VRES integration and storage [18]. Seeing as typical operation ranges noted for electrolysers are 0% – 100% or 15% – 100%, the flexibility and relatively quick

response times strongly suggests that electrolysers in conjunction with hydrogen production can be valuable assets to electric power grid network optimization and operation.

Generally, all of the secondary and tertiary reserves, and demand (side) response programs have response, ramp, and duration times which state-of-the art electrolysers can provide, technologically. The typical response times for secondary and tertiary reserves and dispatchable demand response providers (to ramp up to 100% power) range generally from 1 minute to 30 minutes depending on the nationally defined requirements.

Economics and efficiency of power to gas systems

The economics of any project depend on the application(s), size, operation, technologies, and location. For power to gas systems, there are several possible configurations and applications; nevertheless, overall project economics can remain a barrier to the deployment of these systems. When regarding power to gas to power applications, the efficiency remains low compared to other technologies which are active in fast response and ancillary markets. However, electrolysers and power to gas systems are flexible and have the ability to store electricity in the chemical form of hydrogen for longer periods of time than other electrochemical energy storage methods, which may increase the value of electrical energy storage stored (ratio of electrical energy returned over lifetime energy required for the power to gas asset) [19]. Since electrolysers are created from stacks as well, larger hydrogen systems are modulable and several stacks in parallel can be arranged in order to improve the performance and/or increase the operational range [20]. Nevertheless the efficiency of power to gas systems may be compromised to decrease overall capital expenditures and costs, as dynamic systems can require a complex balance of plant to work at partial loads – especially for the case of systems containing electrolysers coupled to fuel cells [21]. Beyond the pure technical and economical specifications of power to gas technologies, the importance of coupling them to conventional generation to optimized system operation and reduce greenhouse gas emissions, as well as renewable energy sources to ensure “green” hydrogen is also of importance for long term environmental impacts. Additionally, if electrolysers can be coupled with conventional and other generation assets so that their operation is optimized, it can potentially prolong the lifetime and in result decrease the levelized cost of hydrogen produced [22]. As long as the assets are optimized in terms of sizing, storage necessity, and priorities (i.e. producing a fixed amount of hydrogen, utilizing curtailed energy from VRES or smoothing renewable generation profiles injected into the grid, flexibly producing hydrogen while participating in grid-based services for revenues, etc.) can have considerable effects on the economics and returns on project investments. In general, the economics of power to gas projects which participate in ancillary services and energy balancing depends on the pattern of demand, operating

techniques, as well as storage and compression considerations. Nevertheless, depending on emission prices, future spot prices, economies of scale for power to gas technologies, as well as the increase in VRES, arbitrage may become a viable business model for services to the grid in conjunction with hydrogen production via water electrolysis [23]. As more competition enters ancillary service and energy balancing markets, the prices tend to decrease and therefore may be economically less interesting as power to gas systems penetrate the electrical power networks (as storage as well as flexible assets).

Previous studies pertaining to hydrogen participation in electricity markets and services to the grid

Several previous studies have addressed the potential of power to gas systems in electric power networks as well as associated outcomes in sector coupling, integrating increasing renewables, and costs and prices of hydrogen in various scenarios. Below the table (Figure 14) provides a non-exhaustive list of studies regarding hydrogen technologies for services to the grid.

Author	Year	Key findings	ID
Jorgensen and Ropenus	2008	Suggested optimized operation of electrolyzers for hydrogen production using grid electricity in a market with high wind penetration and minimization of the hydrogen production price and its dependence on estimated power price fluctuations. In the West Danish area the price fluctuations can correspond to hydrogen prices varying 0.41–0.45 €/Nm ³	1
Bernal-Agustin and Dufo-Lopez	2010	Completed several techno-economic analyses in order to understand the effect of components in energy generation and resulting electricity prices which affect flexible hydrogen production costs and selling price. Ultimately, the results from these studies suggested that the selling price of hydrogen produced by means of electrolysis is too high in order to recover the initial investment of a PV-wind system in a reasonable lapse of time (i.e. ten years)	2

Barton and Gammon	2010	Simulated several future energy mix scenarios to understand the role of hydrogen in the U.K. The different scenarios suggest that the use of hydrogen in the transport sector is important for reducing CO ₂ emissions – while simultaneously providing demand-side response management for the electric power network. This study stressed the importance of sector coupling of the transport and energy sectors, as scenarios which did not employ hydrogen for transport required substantially larger amounts of imported coal for primary energy sources	3
Bennoua, et al.	2015	Suggested that the most important aspects economically for the deployment of water electrolysis coupled with a generator (like nuclear) depends on the lifetime of the technology as well as its ability to operate as a flexible asset to enable a longer lifetime	4
Mansilla et al.	2012	Explores hydrogen production as a double possibility to be a demand-side management tool: by operating according to price signals from the spot market (avoiding high prices, hence periods when the balance between supply and demand is tense) and through the balancing mechanism (thus helping the system cope with unexpected events occurring close to real-time). The best operating strategy seems to offer lower regulation only (and not raise services). Such operating strategies enable lowering the hydrogen production cost by a few percent in the investigated context. Later, Mansilla et al. (2013) showed that market-driven operation only is not highly favorable to valorize fluctuating hydrogen production, without the added value stream from balancing services. This may change in the context of increasing VRES shares	5
Caumon et al.	2015	Showed to which extent the demand to power the electrolyzers can mitigate the VRES curtailment, showing that hydrogen production can indeed help to integrate fluctuating renewable energies into the power system	6
Cany et al.	2017	Like Caumon, also investigated the opportunity for hydrogen to take advantage from available low-carbon energy in the French context, with increasing VRES. It appears that hydrogen production (as well as any other flexible demand) would be more beneficial for the system than power modulation	7

Larscheid, Lück, and Moser	2018	Examined the potential business models for grid integrated water electrolysis for hydrogen production. Their analyses suggest that for grid-connected electrolysers, exemption from certain system charges is crucial for profitability as well that the economic efficiency is highly dependent on the end-user sector. Despite the potential increased profitability in providing grid services towards transmission operators, this case is highly dependent on the point of grid connection. This publication suggests sector coupling between energy and transport sectors is the most promising scenario in terms of economic potential, and that future decreased investment costs will result in viable business models for power to gas systems (especially deployed in areas with high renewable penetration which are often curtailed)	8
---	------	---	---

Figure 40. Non-exhaustive list of literature studies regarding power to gas services the grid
 Citations of ID: 1 [24], 2 [25], 3 [26], 4 [27], 5 [28], 6 [29], 7 [30], 8 [31]

Essentially of these literature and techno-economic studies suggest that power to gas can be beneficial when using hydrogen for industrial or transport purposes in addition to providing services to the grid and acting as a flexible asset. However, the high investment costs regarding power to gas investments remain a barrier to deploying power to gas technologies in electricity markets for the time being.

Demonstrations which have investigated aspects regarding services to the grid

Several demonstrations around the world have previously addressed the concept of providing services to the grid using power to gas systems – whether they are just electrolysers, fuel cells, or both systems with storage included. Task 38 [32] under the IEA H2 TCP identified over 200 power to gas demonstrations during 2004 – 2020 which addressed potential service to the grid applications for power to gas systems [33]. Below, Figure 41 displays a non-exhaustive list of demonstrations of power to gas systems which aim to participate in ancillary services or energy balancing using either the electrolyser and/or re-electrification with a fuel cell. Here the common applications are described as Demand Management, Load Shifting (which may be in terms of just energy storage or shifting of VRES to respond to peak consumption periods), as well as Curtail avoidance (as some may call surplus energy from generators which are running but not feeding into the grid due to periodic overproduction), as well as Capacity Mechanism which procures capacity for longer, or even seasonal energy balancing and security. Grid balancing is also noted as an application to which power to gas seems to respond well – this is a generic

term for reducing fluctuations in the network, suggesting that the system most likely performs frequency regulation or reserves, VRES smoothing or shifting, or demand management.

Name	System	Size	Application(s)	Actors	Location	Start Date	End Date	ID
HYUNDER	PEM electrolyser and tanks	66 Nm ³ /h	<ul style="list-style-type: none"> ▪ Load shifting ▪ Grid balancing 	Aragon Hydrogen Foundation	Huesca (Spain)	2008	-	1
Myrte	PEM electrolyser, fuel cell, and storage	50kW (120 Nm ³ /h) Fuel cell: 200 kW	<ul style="list-style-type: none"> ▪ Grid balancing 	CEA, Areva	Corsica (France)	2012	-	2
INGRID	Electrolyser with fuel cell and solid-state tanks	1.2 MWe	<ul style="list-style-type: none"> ▪ Grid balancing 	Enertrag AG	(Italy)	2012	2015	3
Don Quichote	PEM and alkaline electrolysers	30 Nm ³ /h	<ul style="list-style-type: none"> ▪ Load shifting 	Hydrogenics	Halle (Belgium)	2012	2018	4
Energie park Mainz	PEM electrolyser	6 MWe	<ul style="list-style-type: none"> ▪ Load shifting (wind) ▪ Curtail avoidance ▪ Frequency Regulation 	Siemens	Mainz (Germany)	2012	-	5

Creative Energy Homes	Li-ion battery with electrolyser	Battery: 24 kWh Hydrogen: 155 kWh	<ul style="list-style-type: none"> ▪ Demand management ▪ Load shifting 	University of Nottingham	Nottingham (UK)	2013	2015	6
Levenmouth Projects*	PEM electrolyser and fuel cell	250 kW electrolyser 100 kW fuel cell	<ul style="list-style-type: none"> ▪ Load shifting (microgrid) 	Logan Energy, Hydrogenics	(Scotland)	2014	-	7
ELYintegration	Alkaline electrolyser	Multi-MW goal	<ul style="list-style-type: none"> ▪ Grid balancing 	Aragon Hydrogen Foundation	Huesca (Spain)	2015	-	8
HyBalance	PEM electrolyser	1.2 MW	<ul style="list-style-type: none"> ▪ Grid balancing 	Hydrogenics, Air Liquide	(Denmark)	2015	-	9
H2PE MGAS	PEM electrolyser	300 kW	<ul style="list-style-type: none"> ▪ Grid balancing 	Consiglio Nazionale della Ricerca, ITM	(Italy)	2016	-	10
Demo 4Grid	Pressurized alkaline electrolyser	4 MW	<ul style="list-style-type: none"> ▪ Grid balancing 	Aragon Hydrogen Foundation	(Austria)	2017	-	11
Quali GridS	PEM and alkaline electrolyzers	50 – 300 kW	<ul style="list-style-type: none"> ▪ Grid balancing 	ITM, Aragon Hydrogen Foundation	(Germany)	2017	-	12
H2Future	PEM electrolyser	6 MW	<ul style="list-style-type: none"> ▪ Grid balancing 	Verbund, Siemens	(Austria)	2017	-	13

Lam Takhong wind hydrogen hybrid project*	PEM electrolyser and fuel cell	Electrolyser: 1 MWe Fuel cell: 200 kWe	<ul style="list-style-type: none"> ▪ Load Shifting (microgrid) 	Hydrogenics	Lam Takhong (Thailand)	2018	-	14
Fukushima Hydrogen Energy Research Field (FH2R)	Alkaline electrolyser	10 MW	<ul style="list-style-type: none"> ▪ Load shifting ▪ Capacity Mechanism 	Toshiba, Asahi	(Japan)	2019	-	15

Figure 41. Non-exhaustive list of PtG demonstrations which address services to the grid

Citations of ID: 1 [34], 2 [35], 3 [36], 4 [37], 5 [38], 6 [39], 7 [40], 8 [41], 9 [42], 10 [43], 11 [44], 12 [45], 13 [46], 14 [47], 15 [48]

*Note that these demonstrations work with microgrids and are not connected to larger electric power networks. These electrolysers may work to stabilize the microgrid or store energy in order to provide energy at later times (when renewables are not producing) or to economically manage peak consumption depending on the load.

In general, these demonstration projects are suggested to possess technology readiness levels (TRL) of ranging around 7 – 8, suggesting that the technology used are overall ready for grid services. The latest demonstrations generally include larger MW-scale electrolysers with shorter response times. For example, Demo4Grid (2017 – 2022) uses a 4 MW pressurized alkaline electrolyser technology (IHT) in Austria with a 2-second response time and ability to operate under partial loads to participate in primary and secondary – ideally the electrolyser will use electricity from a regional hydroelectric plant and commercialize the hydrogen produced for mobility and in the chemical industry [44] [49]. The H2020 demonstration ELYntegration aims to identify potential improvements to high pressure alkaline electrolysers as well to respond and contribute to grid operations. In the near future, the Japanese

demonstration, Fukushima Hydrogen Energy Research Field (FH2R), will be launched. This demonstration aims to deploy a 10 MW electrolyser coupled with a 10 MW solar power plant in collaboration between Toshiba Energy Systems & Solutions Corp, Tohoku-Electric Power Co Inc, Iwatani Corp and Japan's New Energy and Industrial Technology Development Organization (NEDO) to participate in services to the grid – though more on the energy / long discharge duration storage side [48]. NEDO will use H₂ to offset grid loads, and deliver H₂ to locations in Tohoku and beyond, and will seek to demonstrate the advantages of H₂ as a solution in grid balancing and as a H₂ gas supply. Finally, H₂ will be transported in compressed H₂ trailers and be supplied to users. The hydrogen facilities are scheduled to be completed and start trial operation by October 2019, and the verification and the transportation of hydrogen are scheduled to begin for checking technical issues by July 2020 in Namie Town, Fukushima Prefecture, Japan.

Conclusions and remarks

- a. A high share of renewable electricity is crucial for environmental benefits of using hydrogen as energy carrier – certificates of origin, regulatory incentives and legal frameworks require hydrogen systems definitions as well as acknowledgement in participation and standards for operation.
- b. Size, operating conditions, and production logistics all will determine optimal sizing for project economics and certain aspects may need to be compromised to prolong the lifetime, produce less hydrogen, or make less revenues. For example, by shifting (in advance or in delay) from a planned hydrogen production schedule, electrolysers can adapt electricity consumption to variable RES production – and thus provide grid balancing services to better integrate intermittent production
- c. Electrolysers as well as power to gas systems can technically respond to the majority of ancillary and energy balancing services in energy markets; nevertheless, the price of hydrogen, system economics, and overall profitability remain barriers to massive deployment of power to gas systems to participate as a flexible asset in electric power network.
- d. Electric power networks enabling smaller assets, aggregated assets, and taking into account new technology capabilities is crucial for future optimization and transformation of the energy sector. Allowing quick-response and flexible assets to participate in several services (ancillary and/or energy balancing) based on the technical specifications and capabilities is also very important – as “stacking” services is possible with newer technologies and may enable more expensive and clean alternatives to participate economically in the electricity sector.

REFERENCES

1. COAG Energy Council - Energy Security Board. *Post 2025 Market Design Consultation Paper*. 2020 [cited 2020; Available from: <http://www.coagenergycouncil.gov.au/publications/post-2025-market-design-consultation-paper-%E2%80%93-september-2020>].
2. Farhad Billimoria, Pierluigi Mancarella, and R. Poudineh. *Market design for system security in low-carbon electricity grids: from the physics to the economics*. 2020 [cited 2020; Available from: <https://www.oxfordenergy.org/publications/market-design-for-system-security-in-low-carbon-electricity-grids-from-the-physics-to-the-economics/>].
3. Rob Hovsopian. *Role of Electrolyzers in Grid Services*. 2017 [cited 2020; Available from: https://www.hydrogen.energy.gov/pdfs/htac_may17_08_hovsopian.pdf].
4. ENTSO-E. *European Network of Transmission System Operators for Electricity (ENTSO-E)*. 2020 [cited 2020; Available from: <https://www.entsoe.eu/>].
5. ENTSO-E. *ENTSO-E Member Companies*. 2020 [cited 2020; Available from: <https://www.entsoe.eu/about/inside-entsoe/members/>].
6. Roland Berger Strategy Consultants. *Development of Business Cases for Fuel Cells and Hydrogen Applications for Regions and Cities - Electricity Grid Services*. 2017 [cited 2020; Available from: https://www.fch.europa.eu/sites/default/files/FCH%20Docs/171121_FCH2JU_Application-Package_WG5_P2H_Electricity%20grid%20services%20%28ID%202910582%29.pdf].
7. PJM. *Primary Frequency Response Stakeholder Education Part 1 of 2*. 2017 [cited 2020; Available from: <https://www.pjm.com/-/media/committees-groups/task-forces/pfrstf/20170901/20170901-primary-frequency-response-education-part-1-of-2.ashx>].
8. Elaine Hale, et al. *Potential Roles for Demand Response in High-Growth Electric Systems with Increasing Shares of Renewable Generation*. Technical Report NREL/TP-6A20-70630 2018; Available from: <https://www.nrel.gov/docs/fy19osti/70630.pdf>].
9. ARENA. *AEMO and ARENA demand response trial to provide 200 megawatts of emergency reserves for extreme peaks*. News 2017 [cited 2020; Available from: <https://arena.gov.au/news/aemo-arena-demand-response/>].
10. RTE. *Téléchargez les données publiées par RTE - Marché Effacement NEBEF, Volumes, 2014 - [Download data published by RTE - Market for NEBEF mechanism, Volumes, 2014 - current]*. 2020 [cited 2020; Available from: https://www.services-rte.com/en/download-data-published-by-rte.html?category=market&type=demand_response&subType=volumes].
11. regelleistung.net. *Internetplattform zur Vergabe von Regelleistung [German internet platform for dispatch of power generation and services]*. 2020 [cited 2020; Available from: <https://www.regelleistung.net/ext/>].
12. Fingrid. *Demand-side management in Finland*. 2020; Available from: <https://www.fingrid.fi/en/electricity-market/market-integration/the-future-of-the-electricity-markets/demand-side-management/>].

13. UK National Grid. *National Grid EMR Electricity Capacity Report 2018*. 2018 [cited 2020; Available from: <https://www.emrdeliverybody.com/Capacity%20Markets%20Document%20Library/Electricity%20Capacity%20Report%202018.pdf#search=Electricity%20Capacity%20Report%202018>].
14. PJM. *Curtailment Service Providers*. 2020 [cited 2020; Available from: <https://www.pjm.com/markets-and-operations/demand-response/csps.aspx>].
15. Commission, C.P.U. *Demand Response (DR) Programs*. 2020; Available from: <https://www.cpuc.ca.gov/general.aspx?id=5925>.
16. Josh Eichman and Francisco Flores-Espino. *California Power-to-Gas and Power-to-Hydrogen Near-Term Business Case Evaluation*. NREL Technical Report NREL/TP-5400-67384 2016 [cited 2020; Available from: <https://www.nrel.gov/docs/fy17osti/67384.pdf>].
17. *enum 1*.
18. Filip Smeets and D. Thomas. *HyBalance: state-of-the-art PEM electrolysis paving the way to multi-MW renewable hydrogen systems*. 2017 [cited 2020; Available from: http://hybalance.eu/wp-content/uploads/2016/03/Hydrogenics-presentation_HyBalance-inauguration.pdf].
19. Matthew A. Pellow, et al., *Hydrogen or batteries for grid storage? A net energy analysis*. Energy & Environmental Science, 2015. **2015**(8): p. 1938-1952.
20. Parra, D., et al., *A review on the role, cost and value of hydrogen energy systems for deep decarbonisation*. Renewable and Sustainable Energy Reviews, 2019. **101**: p. 279-294.
21. Valverde, L., et al., *Definition, analysis and experimental investigation of operation modes in hydrogen-renewable-based power plants incorporating hybrid energy storage*. Energy Conversion and Management, 2016. **113**: p. 290-311.
22. Bennoua, S., et al., *Role of hydrogen in resolving electricity grid issues*. International Journal of Hydrogen Energy, 2015. **40**(23): p. 7231-7245.
23. Lück, L., et al. *Economic potential of water electrolysis within future electricity markets*. in *2017 14th International Conference on the European Energy Market (EEM)*. 2017.
24. Jørgensen, C. and S. Ropenus, *Production price of hydrogen from grid connected electrolysis in a power market with high wind penetration*. International Journal of Hydrogen Energy, 2008. **33**(20): p. 5335-5344.
25. Bernal-Agustín, J.L. and R. Dufo-López, *Techno-economical optimization of the production of hydrogen from PV-Wind systems connected to the electrical grid*. Renewable Energy, 2010. **35**(4): p. 747-758.
26. Barton, J. and R. Gammon, *The production of hydrogen fuel from renewable sources and its role in grid operations*. Journal of Power Sources, 2010. **195**(24): p. 8222-8235.
27. Mansilla, C., et al., *Electric system management through hydrogen production – A market driven approach in the French context*. International Journal of Hydrogen Energy, 2012. **37**(15): p. 10986-10991.
28. Mansilla, C., et al., *Economic competitiveness of off-peak hydrogen production today - A European comparison*. Energy, 2013. **55**: p. 996-1001.

29. Caumon, P., et al., *Flexible hydrogen production implementation in the French power system: Expected impacts at the French and European levels*. Energy, 2015. **81**: p. 556-562.
30. Cany, C., et al., *Adapting the French nuclear fleet to integrate variable renewable energies via the production of hydrogen: Towards massive production of low carbon hydrogen?* International Journal of Hydrogen Energy, 2017. **42**(19): p. 13339-13356.
31. Larscheid, P., L. Lück, and A. Moser, *Potential of new business models for grid integrated water electrolysis*. Renewable Energy, 2018. **125**: p. 599-608.
32. IEA Hydrogen. *IEA Hydrogen Task 38 - Power-to-Hydrogen and Hydrogen-to-X: System Analysis of the Techno-economic, Legal and Regulatory Conditions*. IEA Hydrogen Activities 2020 [cited 2020; Available from: <http://ieahydrogen.org/Activities/Task-38.aspx>].
33. Dolci, F., et al., *Incentives and legal barriers for power-to-hydrogen pathways: An international snapshot*. International Journal of Hydrogen Energy, 2019. **44**(23): p. 11394-11401.
34. HyUnder. *HyUnder - Modelling Large Scale Underground Hydrogen Storage in Europe*. 2020; Available from: <http://hyunder.eu/>.
35. Corsica, U.o. *Mytre: Research Platform in Energetics - Storing Solar Energy*. 2020; Available from: <https://www.universita.corsica/en/research/myrte/>.
36. Ricerca Sistema Energetico (RSE). *Project INGRID - High-capacity hydrogen-based green-energy storage solutions for grid balancing*. 2020 [cited 2020; Available from: <http://www.rse-web.it/progettieu/progetto/829>].
37. projec, D.Q. *Don Quichote project (Demonstration Of New QUalitative Innovative Concept of Hydrogen Out of wind Turbine Electricity)*. 2018; Available from: <https://www.don-quichote.eu/>.
38. Energiepark-Mainz. *Energiepark Mainz*. 2020; Available from: <https://www.energiepark-mainz.de>.
39. Hosseini, S.E. and M.A. Wahid, *Hydrogen production from renewable and sustainable energy resources: Promising green energy carrier for clean development*. Renewable and Sustainable Energy Reviews, 2016. **57**: p. 850-866.
40. Hydrogen, B.G. *Levenmouth Community Energy Project*. 2020 [cited 2020; Available from: <https://www.brightgreenhydrogen.org.uk/levenmouth-community-energy-project/>].
41. elyintergration. *Grid Integrated Multi Megawatt High Pressure Alkaline Electrolysers for Energy Applications*. 2020 [cited 2020; Available from: <http://elyntegration.eu/>].
42. JU, F. *HyBalance: Call for Proposals*. 2014 [cited 2020; Available from: <https://www.fch.europa.eu/project/hybalance>].
43. JU, F. *High Performance PEM Electrioyzer for cost-effective grid balancing aplciations - HPEM2GAS*. 2015; Available from: <https://www.fch.europa.eu/project/high-performance-pem-electrolyzer-cost-effective-grid-balancing-applications>.
44. European Commission and F. JU. *Demo4Grid - Demonstration for Grid Services Production of Green Hydrogen Greening of Industry*. 2020; Available from: <https://www.demo4grid.eu/>.

45. European Commission and F. JU. *Project QualyGridS - Standardized Qualifying tests of electrolyzers for grid services*. 2019 [cited 2020; Available from: <https://hydrogeneurope.eu/project/QualyGridS?embed>].
46. JU, F. *H2Future - Hydrogen Meeting Future Needs of Low Carbon Manufacturing Value Chains*. 2016 [cited 2020; Available from: <https://www.fch.europa.eu/project/hydrogen-meeting-future-needs-low-carbon-manufacturing-value-chains>].
47. Thailand, E.G.A.o. *EGAT to develop the first wind hydrogen hybrid in Asia to support the future of renewable energy*. 2018; Available from: <https://www.egat.co.th/en/news-announcement/news-release/egat-will-develop-the-first-wind-hydrogen-hybrid-in-asia-to-support-the-future-of-renewable-energy>.
48. New Energy and Industrial Technology Development Organization (NEDO). *NEDO, Toshiba, Tohoku Electric Power and Iwatani Start Construction of Fukushima Hydrogen Energy Research Field*. 2018 [cited 2020; Available from: https://www.nedo.go.jp/english/news/AA5en_100393.html].
49. European Commission. *Demonstration of 4MW Pressurized Alkaline Electrolyser for Grid Balancing Services*. 2017 [cited 2020; Available from: <https://cordis.europa.eu/project/id/736351>].

CHAPTER V

Part 1: Subtask 4 - Systemic approach - The curious case of the conflicting roles of hydrogen in global energy scenarios

Author: Christopher J. Quarton¹, Olfa Tlili², Lara Welder^{3,4}, Christine Mansilla², Herib Blanco⁵, Heidi Heinrichs³, Jonathan Leaver⁶, Nouri J. Samsatli⁷, Paul Lucchese⁸, Martin Robinius³ and Sheila Samsatli ^{*1}

Affiliation:

(1) Department of Chemical Engineering, University of Bath, Claverton Down, Bath BA27AY, UK. E-mail: s.m.c.samsatli@bath.ac.uk

(2) CEA, I-tésé, Université Paris-Saclay, Gif-sur-Yvette, France

(3) Forschungszentrum Jülich, Institute of Energy and Climate Research, Electrochemical - Process Engineering (IEK-3), Wilhelm-Johnen-Straße, 52428 Jülich, Germany

(4) Chair for Fuel Cells, RWTH Aachen University, c/o Institute of Electrochemical Process, Engineering (IEK-3), Forschungszentrum Jülich GmbH, D-52425 Jülich, Germany

(5) Center for Energy and Environmental Sciences, IVEM, University of Groningen, Nijenborgh 6, 9747 AG Groningen, The Netherlands

(6) School of Engineering, Unitec Institute of Technology, Auckland, New Zealand

(7) Process Systems Enterprise Ltd., London SW7 2AZ, UK

(8) CEA, Université Paris-Saclay, Gif-sur-Yvette, France

Three kinds of stakeholders can influence the hydrogen deployment in a specific region:

- 1) industries setting the hydrogen system price (that depends on its costs),
- 2) policy makers that show ambition or not in hydrogen deployment and that act accordingly to make sure the regulatory framework is suitable for it,
- 3) and last but not least, academics and organizations running models and publishing energy system

scenarios, so often used to enlighten industries and policy makers.

After discussing point 1) and 2) in last chapters, Chapter 5 addresses point 3). A review on the role of hydrogen in the renowned global energy scenarios is suggested analyzing whether hydrogen is suitably presented or not, based on the available techno-economic data, but also conducting a deeper analysis to inspect whether hydrogen pathways are well presented in the models used to generate the scenarios. Some conclusions and best practices for scenarios development and hydrogen modelling are provided (ST4). For accurate modelling, accurate data is needed, a discussion on data is hence proposed based on the learning from Task Force Data in part 2 of the Chapter.

Key messages

- Developing a global energy scenario that represents the energy system complexities is challenging
- Whilst more recent studies are beginning to include hydrogen, the role it plays in different scenarios is extremely inconsistent. In this chapter, reasons for this inconsistency are explored.
- Our recommendations include: using the right modelling tools, whilst knowing the limits of the model; including the right sectors and technologies; having an appropriate level of ambition; and making realistic data assumptions. Above all, transparency is essential, and global scenarios must do more to make available the modelling methods and data assumptions used

Abstract

As energy systems transition from fossil-based to low-carbon, they face many challenges, particularly concerning energy security and flexibility. Hydrogen may help to overcome these challenges, with potential as a transport fuel, for heating, energy storage, conversion to electricity, and in industry. Despite these opportunities, hydrogen has historically had a limited role in influential global energy scenarios. Whilst more recent studies are beginning to include hydrogen, the role it plays in different scenarios is extremely inconsistent. In this perspective paper, reasons for this inconsistency are explored, considering the modelling approach behind the scenario, scenario design, and data assumptions. We argue that energy systems are becoming increasingly complex, and it is within these complexities that new technologies such as hydrogen emerge. Developing a global energy scenario that represents these complexities is challenging, and in this paper, we provide recommendations to help ensure that emerging technologies such as hydrogen are appropriately represented. These recommendations include using the right modelling tools, whilst knowing the limits of the model; including the right sectors and technologies; having an appropriate level of ambition; and making realistic data assumptions. Above all, transparency

is essential, and global scenarios must do more to make available the modelling methods and data assumptions used.

Introduction

In order to combat climate change there is increasing interest in achieving net-zero greenhouse gas (GHG) emissions before the end of the century.¹ Energy systems decarbonisation is an essential part of this, as energy sectors contribute around three-quarters of global GHG emissions.²

Renewable energy technologies have progressed tremendously in recent decades, now offering economically credible alternatives to fossil fuels in many sectors.³ However, these technologies are fundamentally different to fossil fuels, so a like-for-like replacement is not possible. Renewable resources such as wind and solar are diffuse and intermittent, creating new challenges for matching energy supplies to demands, in both time and space.^{4,5} Furthermore, fossil fuels have unrivalled storage capabilities. It is essential to find low-carbon energy storage options, for temporal balancing of supply and demand, and use in transport.⁶ We need to develop technologies that will enable increased energy systems flexibility and interconnectivity, while maintaining reliability and stability.^{7,8}

In this context, hydrogen has potential. Apart from small reserves of “natural” hydrogen,⁹ hydrogen is not a resource that can be extracted at scale in the same way as fossil fuels. However, it can be produced with minimal GHG emissions, for example through electrolysis powered by renewable electricity,¹⁰ or from bioenergy or fossil fuels with carbon capture and storage (CCS).¹¹ Hydrogen has many possible energy applications, including for heating, transport, industry, and electricity generation.^{12,13}

Energy scenarios can provide valuable insights into possible future trajectories of energy systems. Many different national, regional and global energy scenarios exist. Some scenarios, such as those produced by global institutions (*e.g.* ref. 14–16), can be very influential to political discourse.

However, energy scenarios are generated using various methods and, given the complexity of the systems being represented, it is unsurprising that the scenarios produce differing results. In particular, the prominence of hydrogen in different scenarios varies noticeably. Hanley *et al.*¹⁷ reviewed the role of hydrogen across different energy scenarios, finding a range of results regarding the uptake of hydrogen. Whilst many scenarios included some hydrogen in the transport sector, uptake of hydrogen in other sectors varied significantly depending on the emphasis in the scenario design. Furthermore, the review found a correlation between the level of ambition (*e.g.* decarbonisation or renewables integration targets) and the contribution of hydrogen in the scenario results.

Given hydrogen's potential to transform energy systems, the variation in its contribution in global energy scenarios is surprising. Whilst Hanley *et al.*¹⁷ identified some of the trends in hydrogen prevalence, they did not explore the reasons for differing results in detail.

In this perspective, we assess hydrogen's potential as a contributor to energy systems, and examine the methods used in global energy scenarios in order to understand the reasons for differing results regarding hydrogen. We focus on global energy scenarios produced by prominent institutions, as these are typically the most influential. The entire scenario development process is considered, including conceptualisation, model construction, and input data. Based on this analysis, we suggest some best practices for energy scenarios so that they can provide the best insight, and correctly quantify the potential of energy technologies such as hydrogen.

Section 2 provides an overview of hydrogen as an energy carrier. Section 3 provides details of hydrogen prevalence in scenarios from 12 global studies. In Section 4, the reasons for varying results between scenarios are discussed. Finally, some conclusions and suggestions for best practice in scenario development are provided in Section 5.

Global energy scenarios and the representation of hydrogen

Energy scenarios

Energy scenarios can address the uncertainties surrounding the socio-technical evolution of energy sectors. Scenarios can be qualitative, relying on inputs from experts and stakeholders, or quantitative, usually based on energy systems models.⁴⁸ Scenario development aims to construct possible futures and the paths leading to them, and can guide strategic decision-making processes, for example for maintaining long-term energy supply-demand balances and optimising investment decisions. Consequently, these scenarios can be highly influential to the future of the technological “ecosystem” in different sectors. Due to the size and complexity of the energy systems being represented by energy scenarios, simplifying assumptions must be made, and these can have significant implications for the scenario results.

Several reviews of model-based scenarios and the modelling tools they use have been carried out, highlighting a variety of methods and results. Pfenninger *et al.*⁵⁸ reviewed energy systems models in the context of present-day energy systems, and identified several challenges that these models face, stemming from the increased complexity of modern energy systems. The review also provided recommendations for modelling practice, encouraging innovation with modelling methods, appropriate handling of uncertainty and modelling transparency. Meanwhile, Gambhir *et al.* reviewed energy scenario results, finding that the level of climate change ambition has a significant effect on the scenario results.⁵⁹ Lopion *et al.*⁶⁰ investigated trends in energy system models developed for national greenhouse gas reduction strategies, in the context of underlying research questions and their shift over time, and found that there is an increasing need for high temporal and spatial resolutions.

As Hanley *et al.*¹⁷ found, the prominence of hydrogen varies significantly between energy scenarios. Whilst many of the scenarios Hanley *et al.* studied included some hydrogen in the transport sector, hydrogen prevalence in other sectors was low, except where hydrogen was a specific focus of the study. The scenarios that focus on hydrogen, such as the IEA Energy Technology Perspectives (ETP) 2 °C “high

hydrogen” scenario,⁶¹ have begun a trend of greater hydrogen representation, and hydrogen prominence is growing in the most recent scenarios.

In this perspective, we discuss why there has been an historical absence of hydrogen in global energy scenarios, and why that is beginning to change. Many energy scenarios exist at regional and national levels, such as the EU Reference scenario,⁶² ASEAN Energy Outlook (SE Asia),⁶³ IDB Lights On scenario (Latin America),⁶⁴ EIA Annual Energy Outlook (USA),⁶⁵ China Renewable Energy Outlook,⁶⁶ the Japan Strategic Energy Plan,⁶⁷ and the Deep Decarbonization Pathways Project (various countries).⁶⁸ However, in this perspective we focus on global scenarios with the greatest international impact.

The 12 studies that were considered are shown in [Table 1](#). We focus on the scenarios from 10 model-based studies and also consider two hydrogen-focussed qualitative scenarios: the IEA Hydrogen and Fuel Cells Technology Roadmap³⁰ and the Hydrogen Council “Scaling Up” scenario,⁵⁷ as they provide a counterpoint for the potential for hydrogen, as perceived by experts and stakeholders.

Table 1. Details of the studies and scenarios that were reviewed. Global studies from influential institutions were chosen, focussing on quantitative (model-based) scenarios. Two qualitative scenarios were also included.

Study	Abbreviation	Model used	Scenario end year	Scenarios
World Energy Outlook (IEA) 2016 (ref. 49)	WEO 2016	World Energy Model + MoMo	2040	Current policies
				New policies
				450 scenario
World Energy Outlook (IEA) 2017 (ref. 50)	WEO 2017	World Energy Model + MoMo	2040	Current policies
				New policies
				Sustainable development
World Energy Outlook (IEA) 2018 (ref. 14)	WEO 2018	World Energy Model + MoMo	2040	Current policies
				New policies
				Sustainable

Study	Abbreviation	Model used	Scenario end year	Scenarios
				development
				The future is electric
The Grand Transition (WEC) 2016 (ref. 15)	WEC	GMM	2060	Hard Rock
				Unfinished Symphony
				Modern Jazz
REmap (IRENA) ⁵¹	REmap	E3ME	2050	Reference
				REmap
Energy Technology Perspectives (IEA) 2016 (ref. 52)	ETP 2016	ETP TIMES + MoMo	2050	6DS
				4DS
				2DS
Energy Technology Perspectives (IEA) 2017 (ref. 53)	ETP 2017	ETP TIMES + MoMo	2060	RTS
				2DS
				B2DS
Energy Revolution (Greenpeace) ⁵⁴	ER	REMix	2050	Reference
				E[R]

Study	Abbreviation	Model used	Scenario end year	Scenarios
				ADV E[R]
Shell scenarios ^{16,55}	Shell	Shell World Energy Model	2100	Mountains Oceans Sky
Global Energy Assessment (IIASA) ⁵⁶	GEA	MESSAGE + IMAGE	2050	Supply (Conv. Trans) Mix (Conv. Trans) Efficiency (Conv. Trans) Supply (Adv. Trans) Mix (Adv. Trans) Efficiency (Adv. Trans)
Hydrogen Council (2017) ⁵⁷	H2 Council	Qualitative	2050	Hydrogen – scaling up
Technology Roadmap: Hydrogen and Fuel Cells (IEA) ³⁰	H2FC Roadmap	Qualitative	2050	2DS high H2

Hydrogen representation in global energy scenarios

Between the 35 scenarios considered there is significant variation regarding which hydrogen technologies and end-use applications are considered, and the level of detail with which they are included. In [Fig. 2](#),

The techno-economic assumptions related to these technologies (mainly SMR, with or without CCS) are often presented, and it is observed that the costs of electrolysis and SMR + CCS are converging.³⁰

Other hydrogen infrastructures, such as transportation and storage, receive little coverage in most studies. A few studies discuss storage, but provide no data, suggesting it is not modelled (GEA,⁵⁶ ER,⁵⁴ H2 Council⁵⁷). Hydrogen transportation receives slightly more coverage, most commonly shipping for global transportation (WEO 2018,¹⁴ H2 Council,⁵⁷ GEA⁵⁶). In general, limited data is provided for transportation, so it is unclear what assumptions are made (*e.g.* how transportation is costed), or whether it is considered at all.

End-use applications are described in more detail in the scenarios. The most prominent end-use is mobility, which is considered in some form in all but WEO 2016 (ref. 49) and WEO 2017.⁵⁰ Fuel Cell Electric Vehicles (FCEVs) for light-duty passenger vehicles (LDVs) are predominant but heavier duty vehicles (HDVs, *e.g.* trucks and buses) are also discussed in more-recent studies (though rarely quantified). Instead, discussion is more focussed on societal issues, such as government policies. The qualitative studies^{30,57} provide more techno-economic data for HDVs. Finally, there is some interest in hydrogen for alternative fuels but limited details on techno-economic assumptions are provided (E[R],⁵⁴ ETP 2017,⁵³ H2 Council⁵⁷).

Beyond mobility, other applications for hydrogen are discussed in less detail. Several studies consider industrial applications, with refining applications such as steel and iron, and chemical applications such as ammonia production being the most popular. Electrification of processes *via* electrolysis is mentioned (WEO 2018 (ref. 14)), but again with little detail. Interactions with the gas grid (either direct hydrogen injection or methanation) are often mentioned in discussion, but rarely quantified in the results (GEA;⁵⁶ WEO 2017,¹⁴ H2FC Roadmap,³⁰ H2 Council⁵⁷). Finally, conversion of hydrogen to electricity and heat is rarely mentioned. Where it is considered, the most common technologies are fuel cells, gas turbines and combined heat and power applications. The E[R] scenarios⁵⁴ are the only ones to include these applications in the scenario results.

Conflicting roles of hydrogen in global scenario results

The variability in representation of hydrogen in scenarios leads to conflicts in the level of contribution of hydrogen in the scenario results. Fig. 3 shows the contribution of hydrogen to final energy demand in 2050 in different sectors, for each of the scenarios that includes hydrogen in its results.

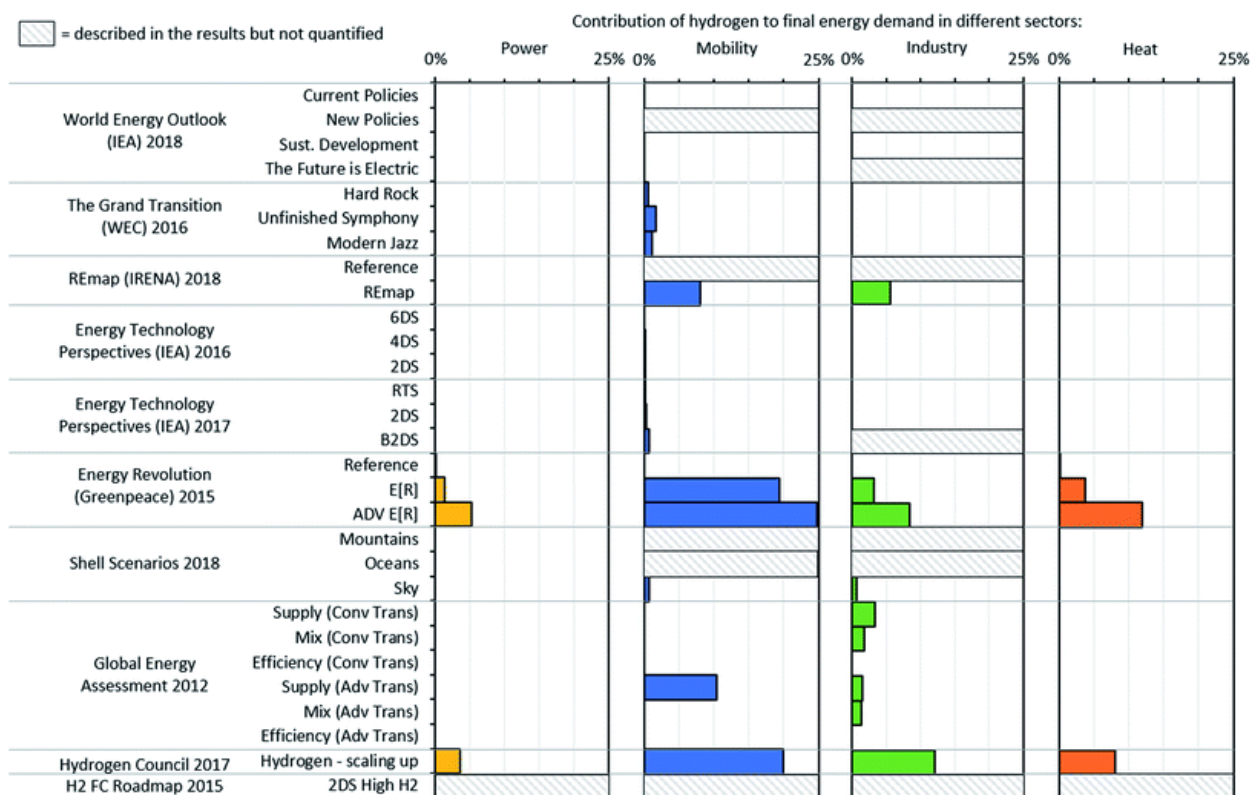

Fig. 3 Contribution of hydrogen to final energy demand in 2050 in power, mobility, industrial and heat sectors for a range of scenarios. Where studies state the inclusion of hydrogen in the results without precisely quantifying it, values have either been estimated by the author (IEA ETP 2016, Shell Sky and H2 Council scenarios), or the result has been denoted by a hashed box.

Overall, the scenarios indicate that hydrogen has the most potential in the mobility sector. Most scenarios have some level of hydrogen in this sector but they offer conflicting levels of contribution: in many cases this is less than 2% of transport energy demand in 2050 (e.g. WEC⁴⁵ and ETP 2017 (ref. 53) scenarios); whereas the Greenpeace E[R] and Adv E[R] scenarios give contributions as high as 19% and 25%, respectively.⁵⁴

Similarly, the contribution of hydrogen in the industrial sector ranges between 0.7% of 2050 industrial demands (Shell Sky¹⁶) and 12% (H2 Council⁵⁷) but many scenarios do not include it at all.

The focus between these two sectors can also shift between scenarios: the Grand Transition scenarios suggest hydrogen should contribute to the mobility sector and not to industry whereas several of the Global Energy Assessment scenarios advocate the opposite.

The Greenpeace scenarios⁵⁴ are the only quantitative scenarios to include hydrogen in the results for the power and heating sectors and both qualitative scenarios also include it (H2FC Roadmap³⁰ and H2 Council⁵⁷).

Discussion: what must scenarios do to represent hydrogen fairly?

From the results in Section 3, and from previous reviews, there is clearly significant variation between scenarios concerning the prominence of hydrogen in energy systems. Although most of these scenarios rely on energy system models, the representation in these models is not sufficient to capture all of the advantages of hydrogen. In this section, we examine the key steps in quantitative scenario development, to understand why differing results may arise, and consider what scenario developers should be doing to make sure hydrogen, and other flexibility options (such as alternative storage technologies, demand-side response, electricity grid expansion and interconnectivity⁷⁰), are appropriately represented.

Scenarios must use appropriate modelling tools

Energy systems models form the basis of most quantitative energy scenarios. A vast number of energy system modelling tools exist and can be categorised in different ways, including simulation vs. optimisation, top-down vs. bottom-up, *etc.* In a review of computing tools for energy systems, Connolly *et al.*⁷¹ identified 68 different energy system modelling tools. Lopion *et al.*⁶⁰ reviewed 24 energy system models in detail, also categorising them as above, and found a clear trend towards techno-economic bottom-up optimisation models in order to answer current research questions.

Each energy systems model is designed for its own unique purpose and has its own strengths and weaknesses. Some of the oldest models were developed in the second half of the 20th century to help understand energy systems in the context of the oil crisis and concerns over security of energy supply.⁵⁸ These models are the predecessors of many models in use today, where due to climate change, we face significantly different energy challenges. It is important that energy systems models in use today are appropriately designed to represent the challenges we face in the twenty-first century.

The most difficult task for modern day energy systems models is to capture the full degree of variability and complexity that exists in energy systems. Traditionally, energy systems were centralised and underpinned by fossil fuels. In the electricity sector for example, supply would be made up of either baseload or dispatchable generation. However, as more and more renewable sources such as solar and wind are introduced to aid decarbonisation, systems are becoming more spatially distributed, technologically diverse and temporally variable. Meanwhile, new technologies and increased interconnectivity are enabling more interaction between different energy sectors, known as “sector-coupling”.⁷² To ensure that energy system models not only provide an accurate representation of energy systems but also do not miss the potential of new technologies such as hydrogen-based technologies, they must capture the required level of temporal, spatial, technological, and inter-sectoral detail.

Models must capture sufficient temporal detail

Many large-scale energy models are unable to represent the time scales at which flexibility technologies such as electrolysers, hydrogen storage and fuel cells are most useful. For example, traditional energy system models typically use representative time slices, such as day, night, and peak for a series of day types throughout the year. In some cases, within-day chronology is retained, meaning that it may be possible to model some level of intraday storage. However longer-term chronology is rarely retained, thus losing the ability to represent long-term storage,^{73,74} which is an area where hydrogen is seen to have strong potential.^{6,75} Novel methods for modelling seasonal storage are beginning to emerge^{76,77} but they have not been applied to any of the global energy scenarios. Meanwhile, short-term dynamics, such as electricity dispatch on a sub-hour basis, are also not modelled by large-scale energy models. This means that another opportunity for hydrogen, as a short-term load balancer through electrolysis,^{78,79} is also missed. The effects of under-representing temporal detail in energy scenarios have been explored and it has been found that investment optimisations will underestimate the contribution of dispatchable power generation and instead favour baseload and intermittent renewables.⁸⁰ It is therefore likely that flexibility options such as those based on hydrogen are also being under-valued.

The challenge for large-scale energy systems models is to capture the full range of time scales necessary. The models are designed for long-term investment planning, and therefore require multi-decadal time horizons. However, the dynamics of the energy system at all time scales (including seasonal, weekly, daily, and sub-hourly) are important to how the system should be designed and operated.⁸¹ Approaches to improve the accuracy of the time-slicing method include using a higher resolution of time intervals; probabilistic representation of the loads and renewable energy supplies; and using real historical data for the time intervals.⁷³ However, each of these approaches suffers the same issue of failing to maintain chronology across the whole time horizon, hence some representation of flexibility is lost. Alternatively, energy systems models can be soft-coupled to power sector models, taking advantage of the latter's improved temporal representation.⁷³ However, this approach can increase overall complexity, as there are two separate models to maintain and run. Furthermore, due to the required iteration between the two models, there is no guarantee that an optimal solution will be obtained.

Models must capture sufficient spatial detail

As well as temporal flexibility, hydrogen can provide spatial flexibility to energy systems. Hydrogen transportation by road, pipeline and shipping provide opportunities for the transportation of energy that cannot be provided by other energy carriers (*e.g.* electricity). Large-scale (*e.g.* global) energy models usually have limited spatial detail, using average resource demands and supplies over large spatial regions.⁵⁸ Consequently, they do not capture the value of energy transportation at a smaller scale, such

as across country. Furthermore, spatial variabilities in solar and wind generation will affect supply profiles across a region: this “spatial smoothing” cannot be fully represented with too coarse a spatial resolution.⁷³

One option for improving this modelling would be to include a higher spatial resolution but this would significantly increase the complexity of the model. Alternatively, models should seek to use representative data and relationships to value within-region energy transportation and distribution.

Models must appropriately represent technologies and inter-sectoral connectivity

Technological representation in large-scale energy models is often restricted to blanket details for each technology type, rather than representing individual technologies or plants.⁸⁰ Consequently, realistic operation of plants, taking their flexibility constraints into account, is not modelled. This is not helped by the lack of temporal resolution and chronology.

To improve technological representation, approaches include further modelling of ancillary markets (*e.g.* flexibility markets), and broader constraints that attempt to represent the overall behaviour of many individual technologies of a given type.⁷³

Finally, hydrogen is central to several sector-coupling options, including power-to-gas (for the gas grid),³⁷ power-to-heat,⁸² power-to-liquids,⁸³ and power-to-ammonia.⁸⁴ Energy systems models need to include the opportunity for transfers of energy between sectors, as this can unlock potential for cost and resource efficiency savings.

Models must represent the complexity of consumer behaviour

Uptake of new technologies is not only driven by cost or efficiency-based metrics for the entire energy system, but also by consumer choice, dependent on social factors and personal preference. For example, market adoption of FCEVs is sensitive to consumer perception of factors such as driving range, battery life, depreciation and capital cost. Furthermore, vehicle uptake is affected by consumer perception in the used vehicle market.

There are significant variations between models regarding how consumer choices are represented, for example the inclusion and relative importance of different utility factors representing consumer choice. Improvements in modelling can be achieved with more readily available data on elasticities and utility factors. Furthermore, a more detailed representation of different technology types (*e.g.* different weight and range categories for vehicles) will allow for a more accurate representation of consumer choice.

Models must remain manageable and user-friendly

Increasing computational power means that larger, more complex and more realistic models can be developed. However, this greater detail can introduce difficulty for the model users, in terms of managing the much larger datasets that are required as inputs and generated as outputs, analysing the results and communicating them to a general audience, such as policy makers and the general public. The challenge for energy systems models is therefore to use appropriate techniques such as those described above whilst preventing the model from becoming too difficult to use and to communicate. Although the detailed outputs of a complex model can be summarised using averages and high-level metrics, some of the important insights can only be understood from the details and presenting these in a manner that is easy to understand remains a key goal and challenge.

Model methodologies must be transparent

Due to the complexities in representing the details of energy systems, it is important that when scenarios are presented, the methodologies behind them are shared. The fact that these models are being used to predict what future energy systems may be, often many decades into the future, means that there is no real-life system against which the models can be validated. As most energy system models use optimisation and today's energy systems are far from optimal, it is difficult even to validate these models against current data. For this reason, it is important that the mathematical formulations behind the models be published so that they can be appropriately peer reviewed. However, this practice is very rare among the global energy scenarios: none of the scenarios reviewed in Section 3 have published the mathematical formulations of their models. Indeed, most give no or very little information regarding the modelling approaches used and only the IEA ETP studies^{52,53} describe qualitatively the modelling framework that is used to generate the results (four soft-linked models are used, including ETP TIMES models for energy conversion and industry, the MoMo model for transport, and the Global buildings sector model for buildings). One might argue that if the results over a wide range of scenarios appear sensible, behave as expected and can be explained, then that is a sufficient test. However, since many modelling assumptions must be made even in complex models, different formulations of the same physical phenomena are possible, and these can result in different but still sensible results.

One barrier to the publication of a model's mathematical formulation is the intellectual property rights of the organisation that developed the model. This is understandable, but the IP is more than just the mathematical constraints employed by the model. It is not practical to publish all of the know-how in the implementation and solution of the model (the minute details required to obtain robust and reliable solutions) and there are many other elements to the IP: data management, user interface, results management and analysis.

The main advantage of model transparency is that this allows other modellers to review the model, highlight any deficiencies and suggest improvements. This will provide researchers and policy makers with the confidence that the results of the scenarios are truly meaningful and that they can be taken forward with real enthusiasm. This can only really be possible by publishing the mathematical formulation of the model, as has been done in other similar areas (see *e.g.* ref. 85–90).

Finally, given that models each have their own strengths and weaknesses, transparency enables scenario developers to choose the model that is best suited to the application. Where energy scenarios are used to inform policy decisions, decision making cannot be considered fully transparent if the methodologies behind the modelling are not themselves transparent.

Challenges and pitfalls

We have argued that models must be much more detailed, and therefore complex, than are currently being used in global energy scenarios. Including features such as high spatial and temporal resolutions, uncertainty analysis, consumer behaviour and including a large range of technologies and energy carriers in a model is extremely challenging. Of course, the models should be made only as complex as is necessary to represent all of the features and details of hydrogen (and other) technologies that may play a role in the future energy system (such as rapid-response load balancing technologies). Modellers and scenario planners should follow a structured approach to developing new models similar to the one below:

1. Describe the purpose of the study carefully.
2. Define the scope so that the purpose can be achieved satisfactorily and with sufficient accuracy.
3. Build the simplest model that can accurately represent all of the features and interactions of the system defined in the scope.
4. Provide assumptions and limitations.
5. Discuss results in light of assumptions and limitations, acknowledging that the model is imperfect.

Deciding the necessary level of detail and accuracy is itself a difficult decision but this can be helped by performing smaller studies involving particular technologies to determine what level of spatial and temporal detail are required. The greatest difficulty for a modeller is when the required level of detail is so high that the model becomes computationally very demanding but further simplifications make the model no longer fit for purpose.

It is understandable that time pressure or intractability may tempt researchers into oversimplifying models in order to obtain results. This is a pitfall that needs to be avoided or at least taken with extreme caution. The results and conclusions obtained from an oversimplified model can be misleading and possibly erroneous. In the context of hydrogen, if a technology does not appear in the results then it is

not possible to determine whether this is because of an inherent disadvantage of the technology or whether it is due to the inadequacy of the model to represent the technology's benefits.

Despite the challenges of including an unprecedented level of detail in energy system models, these are not insurmountable goals. As has been mentioned, techniques have already been developed that allow national energy systems to be optimised with high levels of spatial and temporal disaggregation. With increasing computing power and further research into advanced techniques and algorithms, more complex and detailed models will be possible in the near future. Scenario developers should be aiming to take advantage of these developments in order to obtain more reliable, and perhaps surprising, results.

Scenarios must be designed appropriately

Scenario design, including which sectors and technologies are included, what the level of ambition is, and what performance metrics are used, has a significant influence on scenario results. Scenario design will partly be determined by the capabilities of the model used. However, many decisions will also be made by the developer.

Scenarios must include all relevant sectors

As the results in Section 3 show, there is significant variation in the sectors that are included in different scenarios. Some sectors, such as mobility, are represented in almost all scenarios, but others have significant variability. For example, hydrogen is widely discussed as a key decarbonisation option for industry, as shown by its strong representation in the qualitative scenarios. Furthermore, in almost all quantitative scenarios where hydrogen in industry is included as an option, it contributes to the final results (*e.g.* ReMap, Shell and the Global Energy Assessment). However, several studies omit hydrogen in industry altogether, such as the early WEO and ETP scenarios, the WEC Grand Transition, and even the ambitious Energy Revolution scenarios. Given that hydrogen does appear in the results of many of the scenarios that included it, it is reasonable to wonder if it would have also played a role in the other scenarios had they included it.

The other applications of hydrogen (re-conversion, gas grid) show similar variability between different scenarios and there is no consistent trend regarding which scenarios include which sectors. For studies that have re-produced scenarios in consecutive years (WEO, ETP), it is noticeable that the newer scenarios have a more comprehensive inclusion of sectors than the older scenarios. For example, WEO 2018 had at least some discussion of re-conversion, mobility, industry, and the gas grid, whereas the previous iterations of the study (2016 and 2017) did not consider any of these sectors. Assuming that the modelling methods for these scenarios are not changed significantly from one year to the next, this again suggests that had these sectors been included earlier, they would have been seen in the scenario results. This shows the importance of including the sectors that have the most potential and suggests that awareness

of the potential solutions of applications such as hydrogen is important for their prevalence in scenario results.

Scenarios must be technology rich: a technology not included will not appear in the results

As well as the importance of which sectors are included in a given scenario, it is important to consider which specific technologies are included. Again, Fig. 2 shows the variability in the hydrogen technologies that are included in each scenario. Fig. 2 would suggest that electrolysis is a key technology for hydrogen, as it is included in almost all scenarios. However, some scenarios even omit this technology. Despite referring to hydrogen as a transport fuel and the use of fuel cells, the WEC Grand Transition¹⁵ makes no reference to electrolysis or any other hydrogen production technology. The scenarios with a richer representation of hydrogen production technologies (*e.g.* fossil or biomass-based options as well as electrolysis) typically also include a greater representation of hydrogen in the scenario results.

A challenge for energy scenarios is to keep pace with and to estimate future technology developments so that they can be appropriately represented in scenarios for energy systems several decades in the future. For example, solid oxide electrolysis is a technology with significant interest due to its potential for higher efficiencies, reversible operation and co-electrolysis with carbon dioxide.³⁹ This is reflected in the technology's inclusion in the H2FC Roadmap.³⁰ However, the technology currently has a low level of commercial development, so is not included in any other scenarios.

Some of the most widely discussed advantages of hydrogen are its usefulness as an alternative energy vector, particularly for large-scale storage and transportation. However, these technologies are omitted from many scenarios. Hydrogen has a high volumetric energy compared to alternative energy storage options, so it is seen to have potential for large scale energy storage applications, for example for balancing electricity supplies and demands in systems with large penetrations of intermittent renewable energy. This potential is reflected in the qualitative scenarios, as well as the Shell and GEA scenarios, however no other scenarios include hydrogen storage.

Similarly, another advantage of hydrogen is that it can be transported easily at a range of scales. Unlike electricity, hydrogen can be shipped across long distances internationally, creating the potential for global supply chains.⁹¹ Pipelines also provide the opportunity for hydrogen transportation, and there is interest in both purpose-built hydrogen pipelines and re-purposing existing natural gas grids.³⁷ At a smaller scale, hydrogen can also be transported on road by truck. Like storage, hydrogen transportation is hardly included in any of the scenarios.

The omission of these key hydrogen infrastructures is significant, as they are central to what makes hydrogen a potentially valuable energy carrier in future systems. Whilst the technologies for hydrogen production and consumption may not be the most efficient or the lowest cost, benefits arise from the

efficiency with which hydrogen can be stored and transported, and hence these infrastructures should be included in energy scenarios.

Scenarios must have an appropriate level of ambition

In addition to the technologies and sectors included in the scenario, the level of scenario ambition also influences the prevalence of hydrogen in the results. Most scenarios investigate how an energy system may evolve over time, under existing or expected policies, and can be described as “explorative”; whereas other scenarios impose strict targets on the final energy system and can be referred to as “normative”. Reduction of greenhouse gas emissions is a typical target in normative scenarios. While some explorative global energy scenarios can even show an increase in global greenhouse gas (GHG) emissions, normative scenarios often target drastic cuts in GHG emissions, including nearly net-zero emission scenarios.

Scenarios with higher levels of GHG reduction ambition show a tendency towards a greater prevalence of hydrogen in their results. Drawing quantitative correlations between GHG reductions and hydrogen prevalence is challenging, due to the tendency for scenarios to discuss hydrogen usage without providing specific data. However, Fig. 4 shows estimated hydrogen usage as percentage of total final energy demand in several scenarios, compared with the GHG emissions reduction in the scenario. A negative GHG emissions reduction represents an increase in emissions over the scenario time horizon.

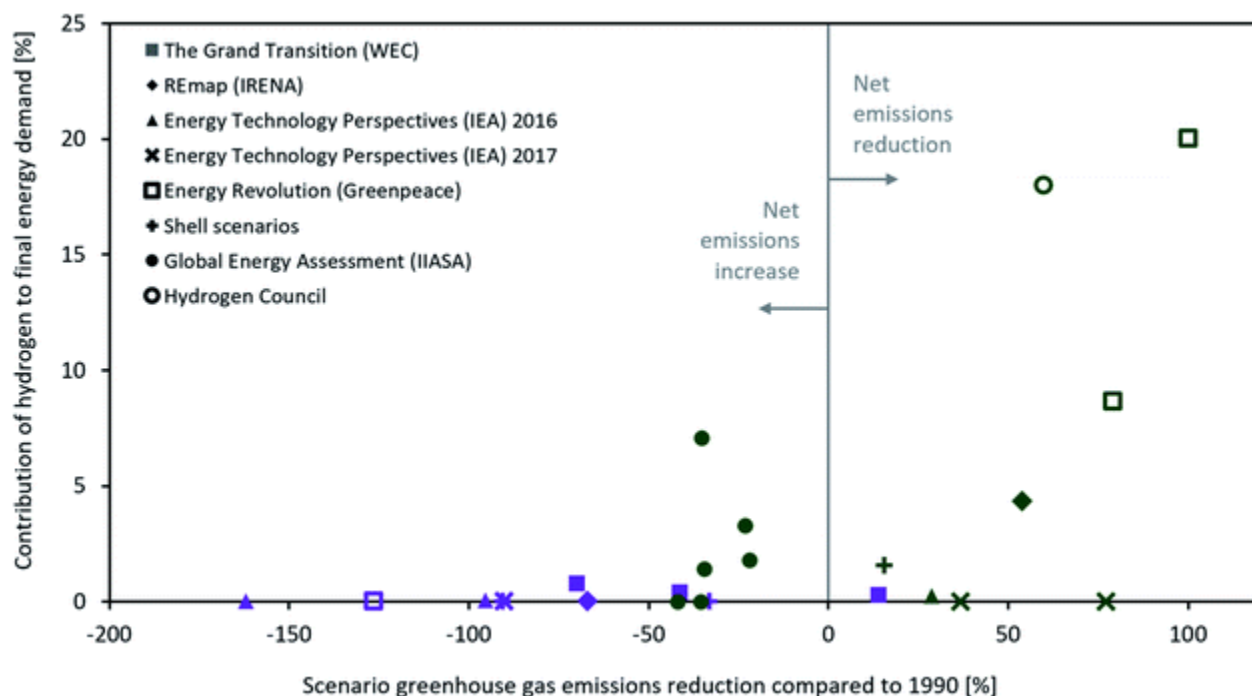

Fig. 4 Effect of greenhouse gas (GHG) emissions reduction on hydrogen prevalence in energy scenarios. A negative GHG emissions reduction represents an increase in emissions over the scenario time horizon. Explorative scenarios are displayed in purple, while normative are displayed in green.

Ambitious GHG reduction targets are achieved to some extent with increased uptake of intermittent renewables such as wind and solar. Consequently, energy system flexibility is required to balance electricity supplies and demands. With intermediate decarbonisation objectives, such as an 80% reduction in emissions, this “backup” can be provided by fossil fuels. However, in close to “net-zero” scenarios, nearly any usage of fossil fuels must be balanced by carbon sequestration. Where carbon sequestration is unattractive (due to technical, economic or social factors), alternatives such as hydrogen for energy storage become much more attractive.

Furthermore, with more variable renewable electricity generators on the grid in ambitious GHG scenarios, there is increased complexity in energy markets, for example with increased occurrence of near-zero power prices arising from excess electricity generation. In these situations, there is greater potential for alternative technologies such as power-to-gas to find viable business cases.^{92,93}

Finally, scenarios with less ambitious decarbonisation objectives do not always consider the decarbonisation of the more challenging sectors, such as industry or long-haul transport. Certain hydrogen pathways, such as power-to-fuels, are particularly attractive in these sectors.⁹⁴

Scenarios must consider other objectives

Besides the level of decarbonisation and renewables integration ambition, many other objectives and constraints, such as political interest, social acceptance and national strategies, may be included in a scenario that will affect its outcomes. For example, nuclear power is a politically controversial technology that many countries are choosing to phase out.⁹⁵ Other potentially controversial technologies include CCS, and even onshore wind power. Meanwhile there are also resource-based constraints: *e.g.* some regions have limited biomass potential, limiting this option for future energy systems aiming for energy independence. These choices shape the scenario design and the evolution of the energy system. As these become more constrained, it is possible that hydrogen pathways will emerge as one of the remaining degrees of freedom to achieve ambitious climate targets.

Scenarios must use consistent and substantiated data assumptions

As well as broad scenario design, the thousands of data parameters that are input into each scenario will influence the scenario results.

Typical input data for technologies in energy systems models will include cost data (*e.g.* capital and operating costs) and performance data (*e.g.* operating rates, efficiencies, environmental impacts, *etc.*). For any technology there will be an uncertainty range in these data, depending on how, when and where

the technology is installed and operated. As an example, some cost estimates for key hydrogen technologies are shown in Table 2, showing the wide uncertainty range in the literature. Energy scenarios are not able to capture this range in every detail, due to the large number of variables already being considered, and consequently must carry out some “averaging”.

Table 2 Cost estimates for key hydrogen technologies for present day and 2050

Technology	Units	Capex		Ref.
		Today	2050	
Electrolyser (alkaline)	€ per kW _{el}	800–1700	400–700	<u>39, 97 and 98</u>
Electrolyser (PEM)	€ per kW _{el}	1300–3200	300–700	<u>39, 97 and 98</u>
SMR (with CC)	€ per kW _{H₂ (HHV)}	600–1300	400–600	<u>11, 30, 98 and 99</u>
H ₂ storage (vehicle on-board)	€ per kW h _{H₂ (HHV)}	13–20	8 (target)	<u>100</u>
Fuel cell (vehicle on-board)	€ per kW _{el}	38–152	34 (target)	<u>100</u>
H ₂ storage (UG compressed)	€ per kW h _{H₂ (HHV)}	0.1–2.0	0.1–2.0	<u>98, 99 and 101</u>
Fuel cell (stationary)	€ per kW _{el}	640–2900	330–1500	<u>30 and 102</u>

Energy scenarios also need to capture the changes in cost and performance data that will occur over time. Rapid progress in energy technologies has been seen before, for example in solar PV³ and lithium-ion batteries.⁹⁶ This sort of progress is dependent on the scale of production. Learning curves can be used to estimate improvements in cost and technical performance with increased production rates but estimating the rates of uptake of technologies is challenging, particularly as these can be influenced by government policy.

Large-scale energy scenarios are typically based on policies that are already in place and free-market decisions. For the future, usually broad policies (*e.g.* system wide GHG targets) are used rather than sector specific. Technology agnostic measures are usually preferred, to promote the development of the most competitive options, and ensure that governments do not choose technologies with higher costs for society. However, due to the learning curve effect, some technologies that are not economically attractive

in the early stages of deployment may deliver a lower long-term cost. This requires additional incentives to go beyond this “valley of death” region to be able to reach that long-term target.¹⁰³

For example, although electrolysis is a relatively well established technology, studies that find hydrogen from electrolysis to be competitive with conventional hydrogen production or even fossil fuel alternatives usually rely on reductions in cost resulting from significant scale-up of production (*e.g. ref. 97*), which most likely would only occur with strong government support. Similarly, for technologies at the R&D level, incentives need to be technology specific since this will determine the research strategy and priorities. In turn, this R&D can lead to cost and efficiency improvements, which will influence the prominence of the technology in energy scenarios. Experience from the power sector has shown that a mix of technology specific and technology neutral policies achieve the best results in promoting low carbon options.¹⁰⁴

Model-based scenario studies should model a full range of technology and policy assumptions. Ideally, sensitivity analysis would be used to understand the significance of different data uncertainties on scenario results. This analysis may also provide insights into the relative value of R&D for different technologies and sectors. Of course, sensitivity analyses can be expensive when applied to large, complex models, hence there is an argument for simpler models, with a more thorough treatment of data uncertainty.¹⁰⁵ Despite this, the models should not be simplified to the point where they no longer represent the energy system with sufficient accuracy, as this will result in unrealistic sensitivities, especially when non-linear effects are involved. The simplified model should only be used for sensitivity analysis and the more-detailed model used to explore interesting “corner” points identified in the analysis – to check that the analysis is correct.

As a minimum, studies should share the data assumptions that were made in their analysis but unfortunately even this is rare. The IEA H2FC Roadmap³⁰ and IASA Global Energy Assessment^{56,106} contain detailed descriptions of the technical and economic performance of most hydrogen technologies throughout the supply chain. However, as Fig. 2 shows, several studies include hydrogen in their scenario results but little or no information at all is given on the data assumptions made (*e.g. WEC,¹⁵ Shell¹⁶*).

Conclusions

Energy systems are becoming more technologically diverse, spatially distributed and temporally variable. Consequently, there is an opportunity for new “flexibility” options, such as hydrogen, to play a role. In the authors' view, the greatest opportunities for hydrogen lie in the industrial and heavy-duty transport sectors, where hydrogen's high energy density and low greenhouse gas emissions could make it the preferred energy carrier. With the establishment of large-scale hydrogen production, transportation and storage infrastructure for these sectors, there will be many opportunities to use hydrogen for additional flexibility in other sectors, such as the power sector.

However, the exact role that new technologies such as hydrogen will have is unclear, and it is the purpose of energy scenarios to help to indicate what the role might be. In the authors' view, global energy scenarios, especially those based on energy system models, have been pessimistic with respect to

hydrogen. This is beginning to change but coverage of hydrogen is still often restricted to a few main applications, such as mobility.

The main challenge for energy systems models is that many of the opportunities for new technologies such as hydrogen are in spaces that previously have not existed in energy systems, for example in energy storage (both at short and long-time scales) and for sector-coupling. Energy systems models have traditionally not been good at representing the fine details, such as temporal variability. Capturing these details, whilst also encompassing the big picture of a long-term global energy transition is computationally and practically complex, and therefore a big challenge for the modelling community. Nonetheless, techniques are emerging to handle these complexities, and computational power is improving all the time, enabling more ambitious projects. We believe that overcoming these challenges will be necessary to determine with confidence the role that hydrogen should play in the future energy mix.

Meanwhile, if global energy scenarios are currently unable to represent all of the fine details and nuances of future energy systems, it is essential that they acknowledge this and do not present their scenario results with overconfidence. Much greater sharing of the methodologies and input assumptions behind energy scenarios is needed, so that the implications of the results can be correctly interpreted. Scenario developers should also constantly improve their practice, informed by findings from elsewhere. Numerous alternative approaches have been developed for exploring the role of new technologies in future energy systems, including qualitative scenarios and more detailed energy systems modelling at smaller scales. All of this research is valuable and should be taken into account with as much esteem as global energy scenarios.

Authors' contribution

All authors conceptualised the study at an initial workshop. CJQ & SS coordinated and drafted the paper. OT & LW performed the review of global energy scenarios. HH provided the analysis of scenario ambition and hydrogen prevalence. CM, NJS & HB helped structure the paper, contributed to the draft and provided feedback. JL and MR provided feedback and additional arguments.

Conflicts of interest

There are no conflicts of interest to declare.

Acknowledgements

The present work was carried out within the framework of Task 38 of the Hydrogen Technology Collaboration Programme of the International Energy Agency. The task is coordinated by the Institute for techno-economics of energy systems (I-tésé) of the CEA, supported by the ADEME. CJQ and SS would like to acknowledge the Department of Business, Energy and Industrial Strategy (BEIS) and the Engineering and Physical Sciences Research Council (EPSRC) for funding his studentship. Thanks also to Dr Ian Llewelyn and Dr Jose M. Bermudez from BEIS for their very valuable inputs and feedback on this work. OT

acknowledges the funding provided by Air Liquide to support her PhD thesis (framework of her contribution to this article). MR acknowledges the Helmholtz Association under the Joint Initiative “Energy System 2050 – A Contribution of the Research Field Energy” and Detlef Stolten for very important contributions and insights. SS would like to thank the EPSRC for partial funding of her research through the BEFEW project (Grant No. EP/P018165/1).

REFERENCES

1. Committee on Climate Change, Net Zero, The UK's contribution to stopping global warming, <http://www.theccc.org.uk/publication/net-zero-the-uks-contribution-to-stopping-global-warming/>, 2019.
2. D. G. Victor , D. Zhou , E. Ahmed , P. K. Dadhich , J. G. J. Olivier , H.-H. Rogner , K. Sheikho and M. Yamaguchi , Introductory Chapter, *Climate Change 2014: Mitigation of Climate Change. Contribution of Working Group III to the Fifth Assessment Report of the Intergovernmental Panel on Climate Change* , Cambridge University Press, Cambridge, United Kingdom and New York, NY, USA, 2014 .
3. International Renewable Energy Agency, Renewable Power Generation Costs in 2017, <http://www.irena.org/publications/2018/Jan/Renewable-power-generation-costs-in-2017>, Abu Dhabi, 2018.
4. H. Ibrahim , A. Ilinca and J. Perron , Energy storage systems – Characteristics and comparisons, *Renewable Sustainable Energy Rev.*, 2008, **12** , 1221 —1250 .
5. A. Gallo , J. Simões-Moreira , H. Costa , M. Santos and E. Moutinho dos Santos , Energy storage in the energy transition context: A technology review, *Renewable Sustainable Energy Rev.*, 2016, **65** , 800 —822 .
6. A. Abdon , X. Zhang , D. Parra , M. K. Patel , C. Bauer and J. Worlitschek , Techno-economic and environmental assessment of stationary electricity storage technologies for different time scales, *Energy*, 2017, **139** , 1173 —1187.
7. R. Schlögl The Revolution Continues: Energiewende 2.0, *Angew. Chem., Int. Ed.*, 2015, **54** , 4436 —4439 .
8. H. Lund , P. Alberg Østergaard , D. Connolly and B. Vad Mathiesen , Smart energy and smart energy systems, *Energy*, 2017, **137** , 556 —565.
9. A. Prinzhofer , I. Moretti , J. Francolin , C. Pacheco , A. D'Agostino , J. Werly and F. Rupin , Natural hydrogen continuous emission from sedimentary basins: The example of a Brazilian H₂-emitting structure, *Int. J. Hydrogen Energy*, 2019, **44** , 5676 —5685.
10. S. Schiebahn , T. Grube , M. Robinius , V. Tietze , B. Kumar and D. Stolten , Power to gas: Technological overview, systems analysis and economic assessment for a case study in Germany, *Int. J. Hydrogen Energy*, 2015, **40** , 4285 —4294.
11. IEA Greenhouse Gas R&D Programme, Techno-Economic Evaluation of SMR Base Standalone (Merchant) Hydrogen Plant with CCS, <https://ieaghg.org/component/content/article/49-publications/technical-reports/784-2017-02-smr-based-h2-plant-with-ccs>, 2017.
12. M. Ball and M. Weeda , The hydrogen economy – Vision or reality?, *Int. J. Hydrogen Energy*, 2015, **40** , 7903 —7919.
13. N. Brandon and Z. Kurban , Clean energy and the hydrogen economy, *Philos. Trans. R. Soc., A*, 2017, **375** , 20160400 .
14. International Energy Agency, World Energy Outlook 2018, <http://www.iea.org/weo2018/>, 2018.
15. World Energy Council, World Energy Scenarios 2016 – The Grand Transition, <http://www.worldenergy.org/publications/entry/world-energy-scenarios-2016-the-grand-transition>, 2016.

16. Shell, Shell Scenarios, Sky, Meeting the goals of the Paris agreement, http://www.shell.com/promos/business-customers-promos/download-latest-scenario-sky/_jcr_content.stream/1530643931055/eca19f7fc0d20adbe830d3b0b27bcc9ef72198f5/shell-scenario-sky.pdf, 2018.
17. E. S. Hanley , J. Deane and B. Ó. Gallachóir , The role of hydrogen in low carbon energy futures – A review of existing perspectives, *Renewable Sustainable Energy Rev.*, 2018, **82** , 3027 —3045.
18. B. Pivovar , N. Rustagi and S. Satyapal , Hydrogen at Scale (H2@Scale) key to a clean, economic, and sustainable energy system, *Electrochem. Soc. Interface*, 2018, **27** , 47 —52.
19. F. Zhang , P. Zhao , M. Niu and J. Maddy , The survey of key technologies in hydrogen energy storage, *Int. J. Hydrogen Energy*, 2016, **41** , 14535 —14552.
20. P. Nikolaidis and A. Poullikkas , A comparative overview of hydrogen production processes, *Renewable Sustainable Energy Rev.*, 2017, **67** , 597 —611.
21. C. Philibert *Renewable Energy for Industry: From green energy to green materials and fuels* , International Energy Agency, 2017.
22. R. Ramachandran and R. K. Menon , An overview of industrial uses of hydrogen, *Int. J. Hydrogen Energy*, 1998, **23** , 593 —598 .
23. P. E. Dodds and S. Demoullin , Conversion of the UK gas system to transport hydrogen, *Int. J. Hydrogen Energy*, 2013, **38** , 7189 —7200.
24. R. Tarkowski Underground hydrogen storage: Characteristics and prospects, *Renewable Sustainable Energy Rev.*, 2019, **105** , 86 —94.
25. A. B. Gallo , J. R. Simões-Moreira , H. K. M. Costa , M. M. Santos and E. Moutinho dos Santos , Energy storage in the energy transition context: A technology review, *Renewable Sustainable Energy Rev.*, 2016, **65** , 800 —822 .
26. Energiepark Mainz, Energiepark Mainz, <http://www.energiepark-mainz.de/en/>, accessed 04 September 2019.
27. Electricity Generating Authority of Thailand, EGAT to develop the first wind hydrogen hybrid in Asia to support the future of renewable energy, 11 April 2018, <http://www.egat.co.th/en/news-announcement/news-release/egat-will-develop-the-first-wind-hydrogen-hybrid-in-asia-to-support-the-future-of-renewable-energy>, accessed 04 September 2019.
28. Ministerial Council on Renewable Energy, Hydrogen and Related Issues, Basic Hydrogen Strategy, http://www.meti.go.jp/english/press/2017/pdf/1226_003b.pdf, 2017.
29. G. Anandarajah , W. McDowall and P. Ekins , Decarbonising road transport with hydrogen and electricity: Long term global technology learning scenarios, *Int. J. Hydrogen Energy*, 2013, **38** , 3419 —3432.
30. International Energy Agency, Technology Roadmap: Hydrogen and Fuel Cells, <http://www.iea.org/publications/freepublications/publication/TechnologyRoadmapHydrogenandFuelCells.pdf> , 2015.
31. E. Ruffini and M. Wei , Future costs of fuel cell electric vehicles in California using a learning rate approach, *Energy*, 2018, **150** , 329 —341.

32. H2stations.org, Hydrogen Refuelling Stations Worldwide, <http://www.netinform.de/h2/h2stations/default.aspx>, accessed 11 September 2019.
33. T. Hua , R. Ahluwalia , L. Eudy , G. Singer , B. Jermer , N. Asselin-Miller , S. Wessel , T. Patterson and J. Marcinkoski , Status of hydrogen fuel cell electric buses worldwide, *J. Power Sources*, 2014, **269** , 975 —993.
34. B.Verheul, Overview of hydrogen and fuel cell developments in China, Holland Innovation Network China, <http://www.nederlandwereldwijd.nl/binaries/nederlandwereldwijd/documenten/publicaties/2019/03/01/waterstof-in-china/Holland+Innovation+Network+in+China+-+Hydrogen+developments.+January+2019.pdf>, 2019.
35. Alstom, Alstom Coradia iLint, <http://www.alstom.com/our-solutions/rolling-stock/coradia-ilint-worlds-1st-hydrogen-powered-train>, accessed 04 September 2019.
36. Hydrogen Europe, Hydrogen in Industry, 2019, <https://hydrogeneurope.eu/hydrogen-industry>, accessed 14 June 2019.
37. C. Querton and S. Samsatli , Power-to-gas for injection into the gas grid: What can we learn from real-life projects, economic assessments and systems modelling?, *Renewable Sustainable Energy Rev.*, 2018, **98** , 302 —316.
38. Central Intelligence Agency, CIA World Factbook, 2019, <http://www.cia.gov/library/publications/the-world-factbook/fields/383.html>, accessed 14 June 2019.
39. A. Buttler and H. Spliethoff , Current status of water electrolysis for energy storage, grid balancing and sector coupling via power-to-gas and power-to-liquids: a review, *Renewable Sustainable Energy Rev.*, 2018, **82** , 2440 —2454 .
40. O. Schmidt , A. Gambhir , I. Staffell , A. Hawkes , J. Nelson and S. Few , Future cost and performance of water electrolysis: An expert elicitation study, *Int. J. Hydrogen Energy*, 2017, **42** , 30470 —30492.
41. G. Morrison , J. Stevens and F. Joseck , Relative economic competitiveness of light-duty battery electric and fuel cell electric vehicles, *Transportation Research Part C: Emerging Technologies*, 2018, **87** , 183 —196
42. S. M. Jarvis and S. Samsatli , Technologies and infrastructures underpinning future CO₂ value chains: A comprehensive review and comparative analysis, *Renewable Sustainable Energy Rev.*, 2018, **85** , 46 —68 .
43. C. J. Querton and S. Samsatli , The value of hydrogen and carbon capture, storage and utilisation in decarbonising energy: Insights from integrated value chain optimisation, *Appl. Energy*, 2019, [10.1016/j.apenergy.2019.113936](https://doi.org/10.1016/j.apenergy.2019.113936) .
44. H. Daggash , C. Heuberger and N. Mac Dowell , The role and value of negative emissions technologies in decarbonising the UK energy system, *Int. J. Greenhouse Gas Control*, 2019, **81** , 181 —198 .
45. S. Brynolf , M. Taljegard , M. Grahn and J. Hansson , Electrofuels for the transport sector: A review of production costs, *Renewable Sustainable Energy Rev.*, 2018, **81** , 1887 —1905.
46. D. Connolly , B. Mathiesen and I. Ridjan , A comparison between renewable transport fuels that can supplement or replace biofuels in a 100% renewable energy system, *Energy*, 2014, **73** , 110 —125.

47. Institute for Sustainable Process Technology, Power to Ammonia, <http://www.topsectorenergie.nl/sites/default/files/uploads/Energie%20en%20Industrie/Power%20to%20Ammonia%202017.pdf>, 2017.
48. A. Ernst , K. H. Biss , H. Shamon , D. Schumann and H. U. Heinrichs , Benefits and challenges of participatory methods in qualitative energy scenario development, *Technol. Forecast. Soc. Change*, 2018, **127** , 245 —257.
49. International Energy Agency, World Energy Outlook 2016, <http://www.iea.org/newsroom/news/2016/november/world-energy-outlook-2016.html>, 2016.
50. International Energy Agency, World Energy Outlook 2017, <http://www.iea.org/weo2017/>, 2017.
51. International Renewable Energy Agency, Accelerating the Energy Transition through Innovation, a working paper based on global REmap analysis, http://www.irena.org/-/media/Files/IRENA/Agency/Publication/2017/Jun/IRENA_Energy_Transition_Innovation_2017.pdf, Abu Dhabi, 2017.
52. International Energy Agency, Energy Technology Perspectives 2016, <http://www.iea.org/etp2016/>, 2016.
53. International Energy Agency, Energy Technology Perspectives 2017, <http://www.iea.org/etp2017/>, 2017.
54. Greenpeace, Energy [R]evolution, A sustainable World Energy Outlook 2015, 100% Renewable Energy for all, <http://www.greenpeace.org/archive-international/en/campaigns/climate-change/energyrevolution/>, 2015.
55. Shell, New Lens Scenarios, A shift in perspective for a world in transition, http://www.shell.com/energy-and-innovation/the-energy-future/scenarios/new-lenses-on-the-future/_jcr_content/par/relatedtopics.stream/1519787235340/77705819dcc8c77394d9540947e811b8c35bda83/scenarios-newdoc-english.pdf?, 2018.
56. International Institute for Applied Systems Analysis, Global Energy Assessment: Toward a Sustainable Future, http://www.iiasa.ac.at/web/home/research/Flagship-Projects/Global-Energy-Assessment/Chapters_Home.en.html, 2012.
57. Hydrogen Council, Hydrogen scaling up, A sustainable pathway for the global energy transition, <http://www.hydrogencouncil.com/wp-content/uploads/2017/11/Hydrogen-scaling-up-Hydrogen-Council.pdf>, 2017.
58. S. Pfenninger , A. Hawkes and J. Keirstead , Energy systems modeling for twenty-first century energy challenges, *Renewable Sustainable Energy Rev.*, 2014, **33** , 74 —86.
59. A. Gambhir , J. Rogelj , G. Luderer , S. Few and T. Napp , Energy system changes in 1.5 °C, well below 2 °C and 2 °C scenarios, *Energy Strategy Reviews*, 2019, **23** , 69 —80.
60. P. Lopion , P. Markewitz , M. Robinius and D. Stolten , A review of current challenges and trends in energy systems modeling, *Renewable Sustainable Energy Rev.*, 2018, **96** , 156 —166.
61. International Energy Agency, Energy Technology Perspectives 2012: Pathways to a Clean Energy System, http://www.iea.org/publications/freepublications/publication/ETP2012_free.pdf, 2012.
62. European Commission, EU Reference Scenario, https://ec.europa.eu/energy/sites/ener/files/documents/20160713%20draft_publication_REF2016_v13.pdf, 2016.

63. ASEAN Centre for Energy, The 5th ASEAN Energy Outlook 2015–2040, <http://www.aseanenergy.org/resources/the-5th-asean-energy-outlook/>, 2017.
64. L. H. Balza , R. Espinasa and T. Serebrisky , *Lights on? Energy needs in Latin America and the Caribbean to 2040* , Inter-American Development Bank, 2016.
65. U.S. Energy Information Administration, Annual Energy Outlook 2019, <http://www.eia.gov/outlooks/aeo/>, 2019.
66. China National Renewable Energy Centre, China Renewable Energy Outlook 2018, <http://boostre.cnrec.org.cn/index.php/2018/11/27/china-renewable-energy-outlook-2018/?lang=en>, 2018.
67. Government of Japan, Strategic Energy Plan, http://www.meti.go.jp/english/press/2018/pdf/0703_002c.pdf, 2018.
68. Deep Decarbonization Pathways Project, Pathways to deep decarbonization 2015 report, SDSN – IDDRI, http://deepdecarbonization.org/wp-content/uploads/2016/03/DDPP_2015_REPORT.pdf, 2015.
69. International Renewable Energy Agency, Global Energy Transformation, http://www.irena.org/-/media/Files/IRENA/Agency/Publication/2018/Apr/IRENA_Report_GET_2018.pdf, 2018.
70. P. D. Lund , J. Lindgren , J. Mikkola and J. Salpakari , Review of energy system flexibility measures to enable high levels of variable renewable electricity, *Renewable Sustainable Energy Rev.*, 2015, **45** , 785 —807
71. D. Connolly , H. Lund , B. Mathiesen and M. Leahy , A review of computer tools for analysing the integration of renewable energy into various energy systems, *Appl. Energy*, 2010, **87** , 1059 —1082.
72. M. Robinius , A. Otto , P. Heuser , L. Welder , K. Syranidis , D. S. Ryberg , T. Grube , P. Markewitz , R. Peters and D. Stolten , Linking the Power and Transport Sectors – Part 1: The Principle of Sector Coupling, *Energies*, 2017, **10** , 956.
73. S. Collins , J. P. Deane , K. Poncelet , E. Panos , R. C. Pietzcker , E. Delarue and B. P. Ó. Gallachóir , Integrating short term variations of the power system into integrated energy system models: A methodological review, *Renewable Sustainable Energy Rev.*, 2017, **76** , 839 —856.
74. L. Kotzur , P. Markewitz , M. Robinius and D. Stolten , Impact of different time series aggregation methods on optimal energy system design, *Renewable Energy*, 2018, **117** , 474 —487.
75. S. Samsatli and N. J. Samsatli , The role of renewable hydrogen and inter-seasonal storage in decarbonising heat – Comprehensive optimisation of future renewable energy value chains, *Appl. Energy*, 2019, **233–234** , 854 —893 .
76. S. Samsatli and N. J. Samsatli , A general spatio-temporal model of energy systems with a detailed account of transport and storage, *Comput. Chem. Eng.*, 2015, **80** , 155 —176 .
77. L. Kotzur , P. Markewitz , M. Robinius and D. Stolten , Time series aggregation for energy system design: Modeling seasonal storage, *Appl. Energy*, 2018, **213** , 123 —135 .
78. Fuel Cells Bulletin ITM achieves rapid response electrolysis in P2G energy storage, *Fuel Cell. Bull.*, 2016, **2016** , 9

79. Fuel Cells Bulletin Hydrogenics wraps up Ontario utility-scale grid stabilization trial, *Fuel Cell. Bull.*, 2011, **2011**, 9.
80. K. Poncelet , E. Delarue , D. Six , J. Duerinck and W. D'haeseleer , Impact of the level of temporal and operational detail in energy-system planning models, *Appl. Energy*, 2016, **162** , 631 — 643 .
81. S. Samsatli , I. Staffell and N. J. Samsatli , Optimal design and operation of integrated wind-hydrogen-electricity networks for decarbonising the domestic transport sector in Great Britain, *Int. J. Hydrogen Energy*, 2016, **41** , 447 —475 .
82. L. G. Ehrlich , J. Klamka and A. Wolf , The potential of decentralized power-to-heat as a flexibility option for the german electricity system: A microeconomic perspective, *Energy Policy*, 2015, **87** , 417 —428 .
83. H. Blanco , W. Nijs , J. Ruf and A. Faaij , Potential for hydrogen and Power-to-Liquid in a low-carbon EU energy system using cost optimization, *Appl. Energy*, 2018, **232** , 617 —639 .
84. J. Ikäheimo , J. Kiviluoma , R. Weiss and H. Holttinen , Power-to-ammonia in future North European 100% renewable power and heat system, *Int. J. Hydrogen Energy*, 2018, **43** , 17295 —17308.
85. D. Henning , S. Amiri and K. Holmgren , Modelling and optimisation of electricity, steam and district heating production for a local Swedish utility, *Eur. J. Oper. Res.*, 2006, **175** , 1224 —1247
86. B. H. Bakken , H. I. Skjelbred and O. Wolfgang , eTransport: Investment planning in energy supply systems with multiple energy carriers, *Energy*, 2007, **32** , 1676 —1689
87. A. Bischi , L. Taccari , E. Martelli , E. Amaldi , G. Manzolini , P. Silva , S. Campanari and E. Macchi , A detailed MILP optimization model for combined cooling, heat and power system operation planning, *Energy*, 2014, **74** , 12 —26 .
88. S. Samsatli , N. J. Samsatli and N. Shah , BVCM: a comprehensive and flexible toolkit for whole-system biomass value chain analysis and optimisation – mathematical formulation, *Appl. Energy*, 2015, **147** , 131 —160
89. S. Samsatli and N. J. Samsatli , A multi-objective MILP model for the design and operation of future integrated multi-vector energy networks capturing detailed spatio-temporal dependencies, *Appl. Energy*, 2018, **220** , 893 —920 .
90. S. Samsatli and N. J. Samsatli , A general mixed integer linear programming model for the design and operation of integrated urban energy systems, *J. Cleaner Prod.*, 2018, **191** , 458 —479.
91. A. Chapman , T. Fraser and K. Itaoka , Hydrogen import pathway comparison framework incorporating cost and social preference: Case studies from Australia to Japan, *Int. J. Energy Res.*, 2017, **41** , 2374 —2391 .
92. G. Guandalini , S. Campanari and M. C. Romano , Power-to-gas plants and gas turbines for improved wind energy dispatchability: Energy and economic assessment, *Appl. Energy*, 2015, **147** , 117 —130 .
93. D. Parra , X. Zhang , C. Bauer and M. K. Patel , An integrated techno-economic and life cycle environmental assessment of power-to-gas systems, *Appl. Energy*, 2017, **193** , 440 —454.
94. S. J. Davis , N. S. Lewis , M. Shaner , S. Aggarwal , D. Arent , I. L. Azevedo , S. M. Benson , T. Bradley , J. Brouwer , Y.-M. Chiang , C. T. M. Clack , A. Cohen , S. Doig and J. Edmonds , *et al.*, Net-zero emissions energy systems, *Science*, 2018, **360** , 6396 .

95. World Nuclear Association, Nuclear Power in the World Today, February 2019, <http://www.world-nuclear.org/information-library/current-and-future-generation/nuclear-power-in-the-world-today.aspx>, accessed 17 June 2019.
96. B. Nykvist and M. Nilsson , Rapidly falling costs of battery packs for electric vehicles, *Nat. Clim. Change*, 2015, **5** , 329 —332 .
97. G. Glenk and S. Reichelstein , Economics of converting renewable power to hydrogen, *Nat. Energy*, 2019, **4** , 216 —222 .
98. I.Walker, B.Madden and F.Tahir, Hydrogen Supply Chain Evidence Base, Element Energy Ltd, <http://www.gov.uk/government/publications/hydrogen-supply-chain-evidence-base>, 2018.
99. Northern Gas Networks, Equinor and Cadent, H21 North of England, <http://www.northerngasnetworks.co.uk/event/h21-launches-national/>, 2018.
- 100.S.Satyapal, U.S. Department of Energy Hydrogen and Fuel Cell Technology Overview, FC EXPO, 2018, http://www.energy.gov/sites/prod/files/2018/03/f49/fcto_doe_h2_fc_overview_satyapal_fc_expo_2018_0.pdf, 2018.
- 101.HyUnder, Assessment of the Potential, the Actors and Relevant Business Cases for Large Scale and Long Term Storage of Renewable Electricity by Hydrogen Underground Storage in Europe, <http://hyunder.eu/publications/>, 2014.
- 102.L. Welder , P. Stenzel , N. Ebersbach , P. Markewitz , M. Robinius , B. Emonts and D. Stolten , Design and evaluation of hydrogen electricity reconversion pathways in national energy systems using spatially and temporally resolved energy system optimization, *Int. J. Hydrogen Energy*, 2019, **44** , 9594 —9607 .
- 103.C. Azar and B. A. Sandén , The elusive quest for technology-neutral policies, *Environmental Innovation and Societal Transitions*, 2011, **1** , 135 —139
- 104.S. de Mello and H. Paulo , Cost-effectiveness as energy policy mechanisms: The paradox of technology-neutral and technology-specific policies in the short and long term, *Renewable Sustainable Energy Rev.*, 2016, **58** , 1216 —1222 .
- 105.S. Pfenninger , L. Hirth , I. Schlecht , E. Schmid , F. Wiese , T. Brown , C. Davis , M. Gidden , H. Heinrichs , C. Heuberger , S. Hilpert , U. Krien , C. Matke , A. Nebel , R. Morrison and B. Müller , *et al.*, Opening the black box of energy modelling: Strategies and lessons learned, *Energy Strategy Reviews*, 2018, **19** , 63 —71.
- 106.International Institute for Applied Systems Analysis, Global Energy Assessment Scenario Database, 11 November 2013, <http://www.iiasa.ac.at/web/home/research/researchPrograms/Energy/Global-Energy-Assessment-Database.en.html>, accessed 6 September 2019

Part 2: Task Force – Data – The challenge of a collaborative database to support evolving modeling needs

Author: Laurence Grand-Clément

Affiliation: Persee, France

Database – General considerations

The term database within IEA HIA tasks often references any collection of related data (such as a spreadsheet or a card index).

Formally, a "database" refers to a set of related data and the way it is organized. A "database management system" (DBMS) is a software package designed to define, manipulate, retrieve, and manage data in a database and provides ways to manage how that information is organized

Existing DBMSs provide various functions that allow management of a database and its data which can be classified into four main functional groups:

- Data definition – Creation, modification and removal of definitions that define the organization of the data.
- Update – Insertion, modification, and deletion of the actual data.
- Retrieval – Providing information in a form directly usable or for further processing by other applications. The retrieved data may be made available in a form basically the same as it is stored in the database or in a new form obtained by altering or combining existing data from the database.
- Administration – Registering and monitoring users, enforcing data security, monitoring performance, maintaining data integrity, dealing with concurrency control, and recovering information that has been corrupted by some event such as an unexpected system failure.

Both a database and its DBMS conform to the principles of a particular database model⁴. "Database

⁴ <https://www.sciencedirect.com/science/article/abs/pii/S0268401209000036>

system" refers collectively to the database model, database management system, and database5.

Task 38, when started, took into account the lessons learnt from previous tasks, which included:

- The importance of initiating data acquisition as early as possible in the process
- The need for visualisation to help data contributors check their inputs in terms of viability and consistency
- The limitations related to sticking to excel as a unique tool when the amount of collected data starts to grow significantly

Database in the IEA Hydrogen TCP Tasks

Data gathered and used in the different tasks cover essentially:

- Geographical energy system representation (including demand), characterized by significant spatial diversity
- HFC Technologies representation, characterized by highly varying maturity (all TRLs involved) and a great diversity
- Lists of reference, studies and reports, increasing in number

Such diversity and complexity constitute, as such, a great challenge.

Besides, the acquisition process inherent to the TCPs is highly collaborative, relying on voluntary contributions from various entities, practices, geographies (e.g. time zones) adding to the challenge.

Finally, the cyclical aspect of a task based organisation does not facilitate the maintenance and long-term management of data across them.

Then, it is yet to be acknowledged that some of the produced data have been lost or left unutilized, some data sets are incomplete making it difficult to reuse, some data are still consistently missing.

Task 38 has proved no stranger to these challenges. Specifically, in Task 38, the effort to carry out was needed around 4 themes:

- Culture: to create alignment amongst the different contributors

5 Beynon-Davies, Paul (2003). Database Systems (3rd ed.). Palgrave Macmillan. [ISBN 978-1403916013](#).

- Process: to standardise data management methods across the participants and the different subtasks
- Structure: to provide a common data base architecture with clear data definition
- Support (tools): to deliver data related advice and possibly build digital tools to facilitate the work of participants

Further to this, task 38 addressed the need for fundamentally richer models, with greater spatial and temporal resolution, allowing a greater representativeness of the temporal and geographic flexibility provided by hydrogen systems. More details on this are addressed in Part I of this Chapter. Building databases to feed such models require larger and evolving datasets, which can be complex and time consuming.

The need for an ad hoc effort around data management

It was then clear that a different approach to data/data management was necessary. More specifically, it was also obvious that excel was no longer the most appropriate tool to support this effort. Excel makes it easy to store data, perform numerical calculations, format cells, and adjust layouts to generate the output and reports to share with others. Unfortunately, there's a price for the flexibility of Excel. While spreadsheets are ideal for creating one-time analysis, they become problematic as the data grows and evolves over time. Maintainability becomes an issue, especially in a collaborative set up. For spreadsheet experts, it's often difficult to understand what databases offer that spreadsheets don't already have. However, one could highlight the advantages below:

- Data structure and normalization through multiple tables
- Scalability: adding more records is free
- Data and Referential Integrity
- Queries and Reports
- Automation through programming

Two concrete examples:

The first attempt focused on supporting the literature review in ST3A. Based on the desired functionalities, structure and supporting tools were proposed and discussed with the IEA.

However, the constraints in terms of programming language and SW infrastructure constituted a bottleneck for Persee to conduct the development of the desired tool and the initiative was stopped as no other resources could be mobilised to address the above mentioned constraints.

The second attempt focused on supporting the modeling effort of ST4. However, the decision about the

model to be used remained unsure for the first few years of the task as model decision remain a key topic at IEA H2 TCP. The idea then was to develop a data structure ‘fit for purpose’ and as the purpose was not defined whilst data collection was going on the data structuring effort, squeezed between the two was not feasible within this approach.

Finally, task force data concluded that the effort around data management is significant and requires proper resources. This is why a new task within the Hydrogen TCP is defined, called Task416. This task aims to address the hydrogen data issue in a closer manner with regards to the needs of different energy system models.

6 Task 41 website : <http://ieahydrogen.org/Activities/Task-41.aspx>

CHAPTER VI

Subtask 5: Power to X Case studies

Author: Carlos Funez¹, Martin Robinius², Darja Markova³, Ezequel Serwatka⁴

Affiliation:

(1) Centro Nacional del Hidrógeno, Spain

(2) Forschungszentrum Jülich GmbH, Institute of Electrochemical Process Engineering (IEK-3), Germany

(3) Energie Institut an der Johannes Kepler Universität Linz, Austria

(4) Hychico, Argentina

After presenting the techno-economic and regulatory aspects of Power to X system deployment, this chapter addresses specific case studies in order to analyse the profitability conditions of hydrogen systems, with different steps of the supply chain and in different countries. The aim is to challenge these systems in different geographic contexts.

Key messages

- The Power to X technologies, whose efficiency increases very rapidly while prices follow a continuous decline, will make a feasible solution in the years to come.
- The most impact parameter in the business cases defined is the electricity price. Lower electricity prices imply a net present value increase and a pay-back reduction.
- If it is possible to profit the by-products like oxygen and heat, the profit facility will increase and the business case will be better.
- The Power to X technologies allows an important carbon dioxide and pollutants reductions. If the carbon dioxide reductions are considered in the business case, the results will be better.
- All the values obtained regarding the sales price in the different business cases (hydrogen, ammonia, and methanol) are aligned with information obtained in different forecast reports.
- All the business case studied in the chapter, the pay-back value when we consider a 10% of Internal Rate Return are always around 18 years.

Introduction

In this chapter specific business cases related with power to X applications (power to ammonia, power to methanol and power to hydrogen mainly) are examined in detail. The characteristics of each power to X application are described. After a short introduction, the location is specified, followed by background information regarding the concrete application. Concrete application and specifications will define the facility requirements. In addition, the local specifications are used to adapt the power to X applications (electricity price, transport price, renewables energies availability, etc.). For this purpose, the case studies in which the power to X facility and the product consumer are distant from each other, include a transport cost. Based on the derived applications, economic and environmental analyses are performed. At the end, characteristic barriers for the case study are identified.

The business cases considered in the ST5 are the following:

- Power to green ammonia for blasting industry in Chile.
- Power to green ammonia produced in Australia and transport to Japan (to use as hydrogen).
- Power to green hydrogen in Austria for the usage in a variety of applications in different sectors.
- Power to green hydrogen produced in Patagonia, Argentina and transport to Japan.
- Power to green hydrogen with waste CO₂ from green methanol production in China.

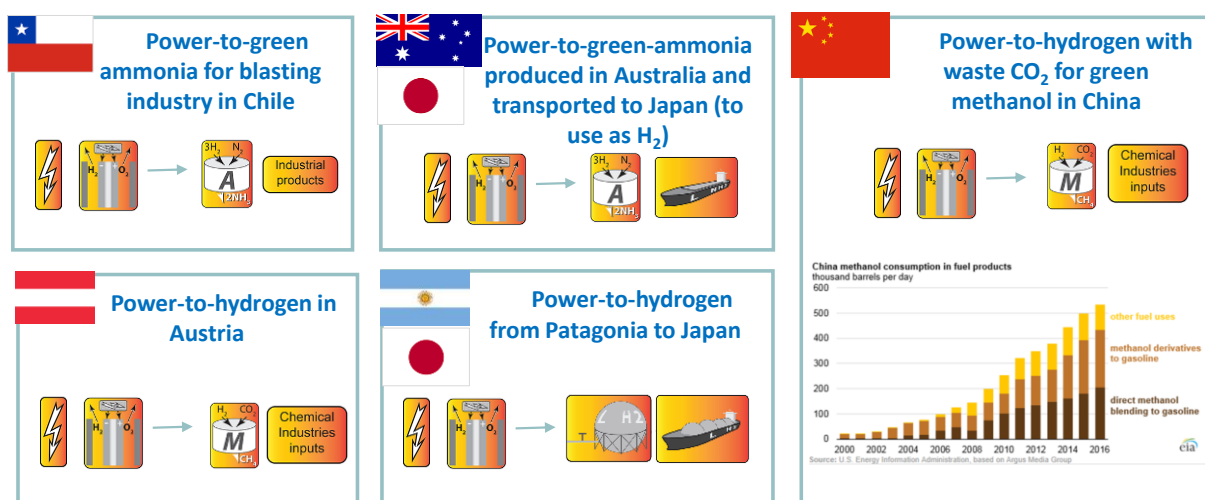

Figure 1: Specific business cases considered in ST5.

These five case studies allow addressing a variety of geographic contexts with different strategies regarding Power to X deployment. The selected applications have important potential by region respectively, following the governmental and industrial orientations

- Chile for instance has an important renewable potential that not only can be exploited “onsite” to decarbonize the energy sector but also can be exported so that other regions with limited

renewable resources and voluntarist hydrogen targets can benefit from this green hydrogen potential [1]. As an “onsite” application, Power to green Ammonia has been selected as Chile has leading industries consuming ammonia for blasting applications (mining activities, etc.).

- Australia has giant export potential [2]. As part of its national strategy [3], these exports will be mainly oriented, in the short term, to the Japanese market [4], [5]. In this case study, hydrogen is transported from Australia to Japan, in the form of ammonia in ships.
- In the south of South America, we can find the Patagonia, both Argentine and Chile. There we have one of the most wind potential worldwide. In this case study, hydrogen is transported from Patagonia, Argentina to Japan, in the form of liquid. This will allow contrasting international hydrogen transport as hydrogen in liquid form (previous case study from Australia to Japan) with transport costs when considering ammonia or liquid carriers.
- China is a giant stakeholder that can, seeing its size, with small shares of hydrogen in its market, bring down the costs. The selected application is Power to green Methanol. The latter being the second hydrogen consumer nowadays in China (after ammonia) [6].
- Austria is a case study from Europe, the latter being among the front-runners to integrate hydrogen. After mainly addressing industrial hydrogen applications, in this case study, Power to green Hydrogen is tackled for a variety of applications in different sectors (mobility, heat, injection in gas networks, etc.). Valorising the excess heat vector is addressed in this case study.

It is clear that a new trend towards international trade of hydrogen is gaining importance in the last few years [7], [8]. Hence, two case studies address this topic. International hydrogen transport is tackled considering two forms: ammonia transport and liquid hydrogen transport.

More insights regarding the adopted methodology are detailed hereafter.

Methodology

The case studies were prepared using expert interviews with stakeholders that currently are working within the task 38 “POWER-TO-HYDROGEN AND HYDROGEN-TO-X”. The economic analysis is based on the Task38 Subtask5 “Specific case studies” excel tool, which for a concrete power to X application, and for a concrete Internal Return Rate, allows defining the hydrogen, methanol, or ammonia price to the market. An explanation of the whole cost components can be found in the Annex.

New technologies typically come to market at a cost premium. Therefore, the Internal Return Rate (IRR), Net Present Value (NPV) and Pay-Back period (PB) of the power to X applications in question were analysed. The analysis is based on data provided by international reports, by the industry and has been challenged and validated by Task 38 experts as well as hydrogen and fuel cells external experts. It is expected that in each business case, the hydrogen, methanol, or ammonia price will change trying to adjust the IRR at 10%. The upside to the business case comes from the utilization of the by-products (oxygen and heat mainly) and the monetisation of externalities (i.e. greenhouse gases emissions). A brief

perspective on this will be provided below. Please note that detailed and location specific business cases (incl. environmental benefits) will be analysed in detail in this study.

The Business Case Tool was developed in the context of the Task 38 Subtask 5 “Specific case studies” to illustrate potential cost of the different products (hydrogen, methanol, or ammonia) development and high-level evolution of total costs for roll-out of different power to X applications with different processes, facility sizes, production processes considering selected specific local framework conditions. As such, the tool provides a good first indication of the effect of different levers on the overall cost development for different power to X applications considered with all the associated infrastructure.

A first input data set contains all cost assumptions for the hydrogen, ammonia or methanol production, storage facilities, transportation and end uses. All the considered power to X applications are in an early stage of development, therefore, current and future costs are difficult to forecast. Also, for hydrogen, ammonia or methanol production and storage facilities, cost figures can vary significantly depending on specific local requirements. Therefore, assumptions included in the tool or in the cases need to be treated with caution and should be validated individually for each deployment project.

For the specific cases studied in this chapter, costs are computed based on basic input parameters for each specific power to X application, country and transportation if is needed. Country-specific data sets were taken into the model (e.g. deployment scheme, feedstock prices, financing costs, energy prices, salaries etc.). The basic cost calculation will also rely on the standard cost data that was already obtained from technical papers and professional experiences. If additional case-specific data was available, the calculation was customised for subsequent example parameters and assumptions for each power to X applications studied in ST5. If no additional parameters were known, the calculation was done based on the general cost that was already obtained from technical papers and professional experiences.

The tool itself does not automatically reflect specific circumstances of individual countries or the parameters of individual local operation set-ups. Therefore, the results generated by this tool are indicative and are no substitute for the development of detailed business cases for individual locations (based on real power to X facilities from potential suppliers) and taking into consideration all individual associated risks and costs (e.g. for prolonged permitting processes, infrastructure configurations differing from the standard assumptions included in the tool, project and stakeholder management etc.). In addition, the tool also takes into account the country-specific feeds price (electricity, water, land rental, transportation, etc.,) for the calculation of the technical and environmental impact assessment. After all parameters for the countries, power to X applications and transportation (if is needed) were defined; the infrastructure and basic concept design was done and discussed with the ST5 stakeholders. These additional configurations of the standard NPV, PB and product price (hydrogen, ammonia or methanol) model will allow the calculation of the NPV, PB and product price items of each power to X application.

Specific Business Case 1. Power to Green Ammonia for Blasting Industry in Chile

Mining industry has been the major consumer of industrial explosives in Latin America, accounting for around 80% of the overall demand in the region. Open-pit mining and underground mining are prominently driving the demand for industrial explosives, whereas the latter accounts for a significant share in the region's industrial explosives landscape.

Increasing investments in metal mining in Latin America is a major factor expected to drive the consumption of industrial explosives in the region. Metal extraction, especially from underground mines, involves intensive use of industrial explosives. Countries in Latin America such as Chile, Peru, Colombia, Brazil, and Bolivia are rich in metallic minerals and thus, metal mining is anticipated to be a major sub-segment in mining, which is anticipated to drive the demand for industrial explosives.

The industrial explosives market landscape in the Latin America region is fairly consolidated with a few players making up majority of the market share. Manufacturers like AEL Mining Services, Enaex S.A., ORICA Ltd., MaxamCorp Holding S.L., Exsa S.A, and Austin Powder Company make up more than 50% of the market share, accounting to more than US\$ 600 Mn in terms of combined revenue of industrial explosives in the Latin America region.

Ammonium nitrate consumption is one of the main industrial explosives because of its safety advantage over other products such as dynamite. Ammonium nitrate can be shipped and stored and mixed with fuel oil when needed. Ammonium nitrate fuel oil (ANFO) is made of about 94% ammonium nitrate and 6% fuel oil. ANFO is widely used as an explosive in mining, quarrying, and tunneling construction or wherever dry conditions exist.

The industrial production of ammonium nitrate entails the acid-base reaction of ammonia with nitric acid: $\text{HNO}_3 + \text{NH}_3 \rightarrow \text{NH}_4\text{NO}_3$. Ammonia is used in its anhydrous form (a gas) and the nitric acid is concentrated. The ammonia required for this process is obtained usually by the Haber process from nitrogen and hydrogen. Existing ammonia production plants are a major emitter of CO_2 , accounting for around 1.6 per cent of current global emissions.

While being cost-effective for today's industrial uses of ammonia, the use of fossil feedstock and energy sources means ammonia has yet to play a role as an energy vector but that is now changing. Today, hydrogen is produced via steam methane reforming, by moving over to green hydrogen, that is hydrogen produced with renewable energy via water electrolysis, the carbon emissions from producing ammonia can be negated.

The main goal of this business case study is the **production of 300 tonnes per day of green ammonia in order to be used in the ammonia nitrate production for blasting industry in Chile (figure 2).**

In order to produce 300 tonnes per day of green ammonia, a facility with the following main equipment is necessary:

- 120 MW of alkaline electrolyser (127.2 MW total power supply to the complete electrolysis system and 120 MW total power supply to the electrolyser stack system). This green hydrogen production facility needs up to 127.2 MWh of green electricity and 33,424 liters/h of water in order to produce up to 2,335 kg/h of hydrogen (99,95% of purity and 30 bar of pressure), up to 18,591 kg/h of oxygen (98,5% of purity and ambient pressure) and up to 28.8 MWh of thermal energy (temperatures between 60°C and 50°C).
- Low pressure hydrogen storage with 56.5 tonnes of capacity at 30 bar of pressure.
- Hydrogen compression system in order to compress the hydrogen from the low-pressure hydrogen storage up to the Haber-Bosch system. The hydrogen compression system will compress up to 2,355 kg/h of hydrogen from 10 to 30 bar of pressure.

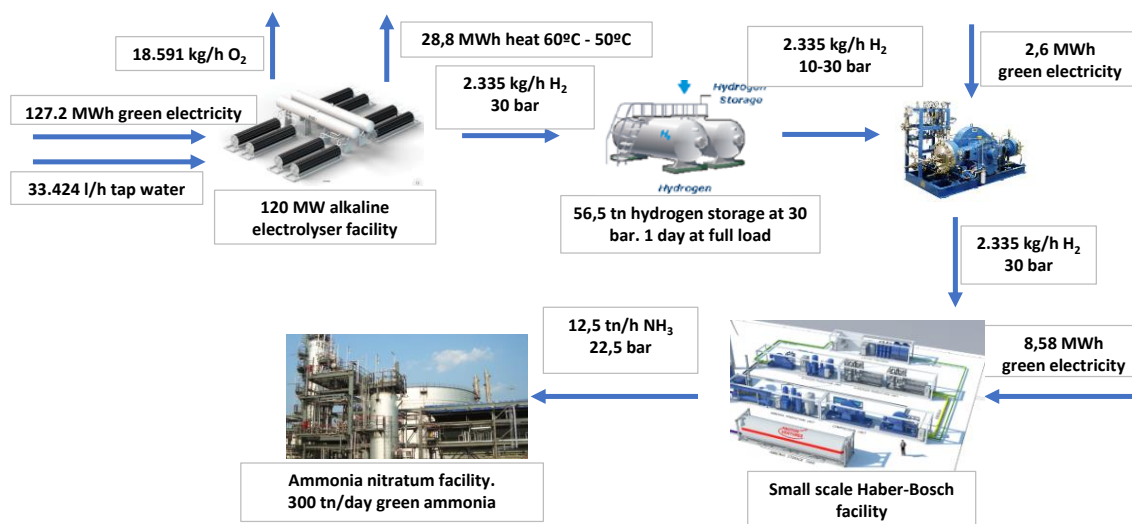

Figure 2: Power to Green Ammonia in order to produce up to 300 tonnes per day.

- Small size Haber-Bosch process in order to produce up to 12.5 tonnes/h of green ammonia. The nitrogen will be taken from the air using an Air Separation Unit (ASU). This facility can reach up to 300 tonnes/day of green ammonia. The green ammonia production will be sent directly to an ammonia storage existing in the ammonium nitrate facility.

The main goal of the facility is to produce green ammonia. However, it is possible to use the oxygen as well as the heat as by-products due to the facility location (industrial area with a lot of industries around).

Each tonne of hydrogen produced via electrolyser with green electricity instead of steam methane reforming reduces around 12,1 tonnes of CO₂. In this regard, this facility can reach a reduction of CO₂ emissions that usually ammonia facilities need to buy in the market. This means that the facility receives revenues from CO₂ emissions reduction.

As previously indicated, in order to be economically viable, the produced green ammonia price must allow reaching an Internal Rate of Return (IRR) of 10%. The main technical and economic considerations taken into account are the following:

- Study period: 20 years.
- Price of green electricity supplied with a Purchase Procurement Agreement (PPA): 32 €/MWh.
- Tap water cost: 2 € per cubic meter.
- Operation hours per year: 8,000.
- Alkaline electrolyser CAPEX: 600 €/kW.
- Alkaline electrolyser system OPEX (% investment cost per year): 1.5.
- Operation hours up to 10% of stack degradation: 80,000.
- Stack replacement cost (% of the total cost): 20%.
- Low pressure hydrogen storage at 30 bar CAPEX (€/kg): 245.
- Low pressure hydrogen storage system OPEX (% investment cost per year): 0.5.
- Hydrogen compression system from 10 to 30 bar CAPEX (€/kg/h): 2,112.8.
- Hydrogen compression system from 10 to 30 bar OPEX (% investment cost per year): 6.
- Haber-Bosch system CAPEX (€/kW of electrolyser system): 450.
- Haber-Bosch system OPEX (% investment cost per year): 5%.
- Personal cost (€/year): 1,000,000.
- Land rental cost (€/year): 200,000.
- French loan duration: 10 years.
- Finance (% of the total investment): 70.
- Own resources (% of the total investment): 30.
- Financial interest (%): 5.
- Taxes (%): 25.
- Integration cost (piping, electricity, control, safety, etc.,) (% of the main equipment): 12.
- Depreciation (%): 95.
- Depreciation (years): 20.
- Discount rate (%): 7.5.
- Inflation (% per year): 1.5.
- Weighted Average Cost of Capital (WACC) (%): 9.11.
- Oxygen sales price (€/tonne): 30.
- Heat sales price (€/MWh): 15.
- CO₂ avoided emission rights (€/tonne): 28.5.

The main results of this specific business case, taking into account that the goal is fix (10% IRR), are the following (see picture 3):

- Total investment needed (€): 163,141,763.
- **Ammonia sales price (€/tonne): 459.67.**
- Total cost per year (€). The total cost can be different in the years because the degradation of the electrolyser stack and the degradation of the Haber-Bosch reactor make that the hydrogen and

ammonia production change in the years. However, the total cost per year is between 47 and 41 million euros.

- Total revenues per year (€). In the same way that the total cost per year, the total revenues per year is between 63 and 57 million euros.
- CO₂ emission reduction per year (tonnes of CO₂): In the same way that the total cost per year, the CO₂ emission reduction per years is between 238,000 and 211,000.
- Net Present Value (NPV) (€): 4,885,196.
- Pay-Back (PB) (years): 18.15.

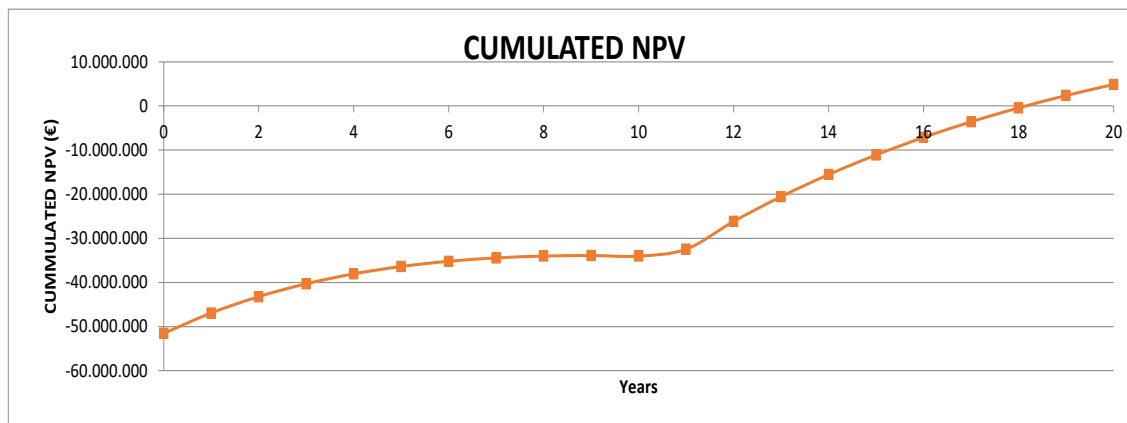

Figure 3: Cumulated Net Present Value VS years.

In order to know how the business case can change when some parameters are changed, some sensitivity analysis is performed. Two of the main parameters are the ammonia sales price (€/tonne) and the CO₂ emission right (€/tonne). The sensitivity analysis will consider for one hand ammonia sales price (€/tonne) from 350 up to 550, and for the other hand CO₂ emission right (€/tonne) from 10 up to 100. The parameter that will be observed in the sensitivity analysis is the Internal Rate of Return (IRR). IRR lower than 10% will be put in white colour and IRR higher than 10% will be put in green colour. All the combinations between ammonia sales price and CO₂ emissions that obtain an IRR higher than 10% (green colour) will be desirable scenarios for the investors (figure 4).

Ammonia production in northern Chile seems a particularly low hanging fruit, due to the existence in the area of a mature solar market, with an excellent resource, interesting wind options, available water desalination technology, better present financial conditions, and large local consumption due to mining, in particular for the direct use in explosives (as well as local consumption of oxygen and heat).

Armijo and Philibert [9] in their study related with green hydrogen and ammonia production in Chile and Argentina estimated near-term production costs for green hydrogen, around 2 USD/kg, and green ammonia, below 500 USD/t, are encouragingly close to competitiveness against fossil-fuel alternatives. In this study the authors consider the best locations in Chile like Taltal and Atacama.

In the figure 5 the ammonia cost in Chile is represented in a period between 2004 and 2018. Following the blue line, it is possible to see the ammonia price when the hydrogen is produced using steam methane reforming (SMR) [10]. The red line is the ammonia price that Armijo and Philibert estimate in their study. Our results show a value of 459.67 €/tonne for the ammonia price which corresponds to more or less 542 USD/tonne, depending on the currency change value between American Dollar and Euro. This value is a little bit higher than the value obtained for Armijo and Philibert. However, the green ammonia production coming from this specific business case is cheaper than the conventional ammonia (with H₂ from SMR) price in 5 of the 14 years represented in the figure 5. The fluctuation in the ammonia cost in Chile depends mainly on the natural gas price and the transport costs.

		AMMONIA SALES PRICE (€/tonne)											
		350	370	390	410	430	450	459,67	470	490	510	530	550
CO ₂ EMISSION RIGHT PRICE (€/tonne)	10	-11,12%	-7,52%	-4,44%	-1,64%	0,99%	3,53%	4,75%	6,04%	8,56%	11,11%	13,72%	16,41%
	15	-9,01%	-5,74%	-2,84%	-0,15%	2,43%	4,95%	6,16%	7,46%	9,99%	12,57%	15,23%	17,96%
	20	-7,11%	-4,08%	-1,31%	1,31%	3,85%	6,36%	7,57%	8,88%	11,44%	14,06%	16,75%	19,53%
	25	-5,36%	-2,49%	0,18%	2,74%	5,26%	7,77%	9,00%	10,31%	12,90%	15,56%	18,31%	21,14%
	28,5	-4,20%	-1,42%	1,20%	3,74%	6,25%	8,77%	10,00%	11,33%	13,94%	16,63%	19,41%	22,28%
	35	-2,15%	0,50%	3,06%	5,58%	8,09%	10,63%	11,88%	13,23%	15,90%	18,66%	21,50%	24,44%
	40	-0,64%	1,95%	4,48%	6,99%	9,52%	12,09%	13,35%	14,72%	17,44%	20,24%	23,14%	26,13%
	45	0,83%	3,38%	5,89%	8,41%	10,96%	13,56%	14,85%	16,24%	19,01%	21,86%	24,81%	27,85%
	50	2,27%	4,79%	7,30%	9,84%	12,41%	15,06%	16,37%	17,79%	20,60%	23,51%	26,51%	29,59%
	55	3,69%	6,20%	8,72%	11,28%	13,89%	16,58%	17,91%	19,36%	22,23%	25,19%	28,23%	31,37%
	60	5,11%	7,62%	10,16%	12,74%	15,40%	18,13%	19,49%	20,96%	23,88%	26,89%	29,99%	33,16%
	65	6,52%	9,04%	11,60%	14,23%	16,93%	19,71%	21,09%	22,59%	25,56%	28,62%	31,76%	34,98%
	70	7,93%	10,48%	13,07%	15,74%	18,48%	21,32%	22,73%	24,25%	27,27%	30,38%	33,56%	36,82%
	75	9,36%	11,93%	14,56%	17,27%	20,07%	22,96%	24,39%	25,94%	29,01%	32,16%	35,39%	38,68%
	80	10,80%	13,40%	16,08%	18,83%	21,68%	24,63%	26,08%	27,66%	30,77%	33,97%	37,23%	40,55%
	85	12,25%	14,90%	17,62%	20,43%	23,33%	26,32%	27,80%	29,40%	32,56%	35,80%	39,09%	42,45%
90	13,73%	16,42%	19,19%	22,05%	25,00%	28,04%	29,55%	31,17%	34,37%	37,64%	40,97%	44,36%	
95	15,23%	17,96%	20,79%	23,70%	26,70%	29,79%	31,32%	32,96%	36,21%	39,51%	42,87%	46,28%	
100	16,76%	19,54%	22,41%	25,38%	28,43%	31,57%	33,11%	34,78%	38,06%	41,39%	44,78%	48,22%	

Figure 4: Sensitivity analysis between green ammonia sales price and CO₂ emission right price.

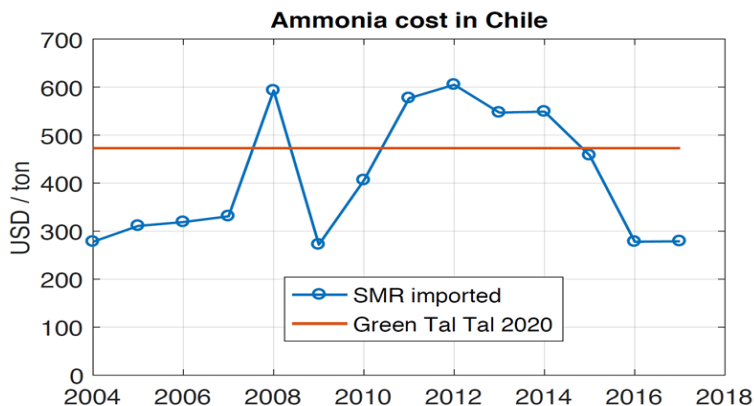

Figure 5: Market costs of ammonia in Chile, compared with Taltal estimate with advanced flexibility at 483 USD/t.

Specific Business Case 2. Power to Green Ammonia Produced in Australia and Transport to Japan (to use as hydrogen)

Mining industry has been the major consumer of industrial explosives in Latin America, accounting for around 80% of the overall demand in the region. Open-pit mining and underground mining are prominently driving the demand for industrial explosives, whereas the latter accounts for a significant share in the region's industrial explosives landscape.

Increasing investments in metal mining in Latin America is a major factor expected to drive the consumption of industrial explosives in the region. Metal extraction, especially from underground mines, involves intensive use of industrial explosives. Countries in Latin America such as Chile, Peru, Colombia, Brazil, and Bolivia are rich in metallic minerals and thus, metal mining is anticipated to be a major sub-segment in mining, which is anticipated to drive the demand for industrial explosives.

The industrial explosives market landscape in the Latin America region is fairly consolidated with a few players making up majority of the market share. Manufacturers like AEL Mining Services, Enaex S.A., ORICA Ltd., MaxamCorp Holding S.L., Exsa S.A, and Austin Powder Company make up more than 50% of the market share, accounting to more than US\$ 600 Mn in terms of combined revenue of industrial explosives in the Latin America region.

Ammonium nitrate consumption is one of the main industrial explosives because of its safety advantage over other products such as dynamite. Ammonium nitrate can be shipped and stored and mixed with fuel oil when needed. Ammonium nitrate fuel oil (ANFO) is made of about 94% ammonium nitrate and 6% fuel oil. ANFO is widely used as an explosive in mining, quarrying, and tunneling construction or wherever dry conditions exist.

The industrial production of ammonium nitrate entails the acid-base reaction of ammonia with nitric acid: $\text{HNO}_3 + \text{NH}_3 \rightarrow \text{NH}_4\text{NO}_3$. Ammonia is used in its anhydrous form (a gas) and the nitric acid is concentrated. The ammonia required for this process is obtained usually by the Haber process from nitrogen and hydrogen. Existing ammonia production plants are a major emitter of CO_2 , accounting for around 1.6 per cent of current global emissions.

While being cost-effective for today's industrial uses of ammonia, the use of fossil feedstock and energy sources means ammonia has yet to play a role as an energy vector but that is now changing. Today, hydrogen is produced via steam methane reforming, by moving over to green hydrogen, that is hydrogen produced with renewable energy via water electrolysis, the carbon emissions from producing ammonia can be negated.

The main goal of this business case study is the **production of 300 tonnes per day of green ammonia in order to be used in the ammonia nitrate production for blasting industry in Chile (figure 2).**

In order to produce 300 tonnes per day of green ammonia, a facility with the following main equipment is necessary:

- 120 MW of alkaline electrolyser (127.2 MW total power supply to the complete electrolysis system and 120 MW total power supply to the electrolyser stack system). This green hydrogen production facility needs up to 127.2 MWh of green electricity and 33,424 liters/h of water in order to produce up to 2,335 kg/h of hydrogen (99,95% of purity and 30 bar of pressure), up to 18,591 kg/h of oxygen (98,5% of purity and ambient pressure) and up to 28.8 MWh of thermal energy (temperatures between 60°C and 50°C).
- Low pressure hydrogen storage with 56.5 tonnes of capacity at 30 bar of pressure.
- Hydrogen compression system in order to compress the hydrogen from the low-pressure hydrogen storage up to the Haber-Bosch system. The hydrogen compression system will compress up to 2,355 kg/h of hydrogen from 10 up to 30 bar of pressure.

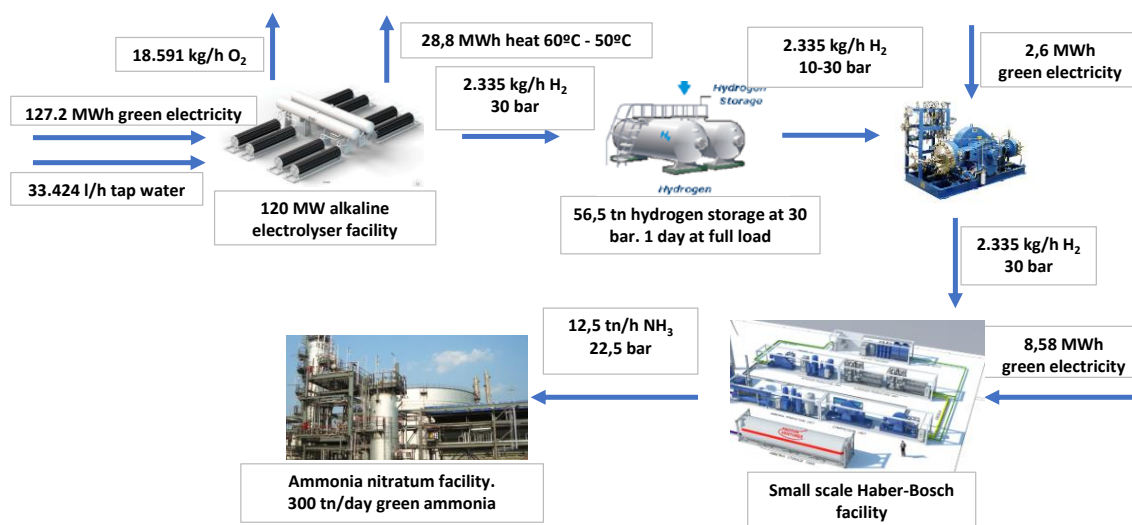

Figure 2: Power to Green Ammonia in order to produce up to 300 tonnes per day.

- Small size Haber-Bosch process in order to produce up to 12.5 tonnes/h of green ammonia. The nitrogen will be taken from the air using an Air Separation Unit (ASU). This facility can reach up to 300 tonnes/day of green ammonia. The green ammonia production will be sent directly to an ammonia storage existing in the ammonium nitrate facility.

The main goal of the facility is to produce green ammonia. However, it is possible to use the oxygen as well as the heat as by-products due the facility location (industrial area with a lot of industries around).

Each tonne of hydrogen produced via electrolyser with green electricity instead steam methane reforming reduce around 12,1 tonnes of CO₂. In this regard, this facility can reach reduction of the CO₂ emission rights that usually the ammonia facilities need to buy in the market. This means that the facility receives revenues from CO₂ emissions reduction.

As previously indicated, in order to be economically viable, the produced green ammonia price must allow reaching an Internal Rate of Return (IRR) of 10%. The main technic and economic considerations taken into account are the following:

- Study period: 20 years.
- Price of green electricity supplied with a Purchase Procurement Agreement (PPA): 32 €/MWh.
- Tap water cost: 2 € per cubic meter.
- Operation hours per year: 8,000.
- Alkaline electrolyser CAPEX: 600 €/kW.
- Alkaline electrolyser system OPEX (% investment cost per year): 1.5.
- Operation hours up to 10% of stack degradation: 80,000.
- Stack replacement cost (% of the total cost): 20%.
- Low pressure hydrogen storage at 30 bar CAPEX (€/kg): 245.
- Low pressure hydrogen storage system OPEX (% investment cost per year): 0.5.
- Hydrogen compression system from 10 to 30 bar CAPEX (€/kg/h): 2,112.8.
- Hydrogen compression system from 10 to 30 bar OPEX (% investment cost per year): 6.
- Haber-Bosch system CAPEX (€/kW of electrolyser system): 450.
- Haber-Bosch system OPEX (% investment cost per year): 5%.
- Personal cost (€/year): 1,000,000.
- Land rental cost (€/year): 200,000.
- French loan duration: 10 years.
- Finance (% of the total investment): 70.
- Own resources (% of the total investment): 30.
- Financial interest (%): 5.
- Taxes (%): 25.
- Integration cost (piping, electricity, control, safety, etc.,) (% of the main equipment): 12.

- Depreciation (%): 95.
- Depreciation (years): 20.
- Discount rate (%): 7.5.
- Inflation (% per year): 1.5.
- Weighted Average Cost of Capital (WACC) (%): 9.11.
- Oxygen sales price (€/tonne): 30.
- Heat sales price (€/MWh): 15.
- CO₂ avoided emission rights (€/tonne): 28.5.

The main results of this specific business case, taking into account that the goal is fix (10% IRR), are the following (see picture 3):

- Total investment needed (€): 163,141,763.
- **Ammonia sales price (€/tonne): 459.67.**
- Total cost per year (€). The total cost can be different in the years because the degradation of the electrolyser stack and the degradation of the Haber-Bosch reactor make that the hydrogen and ammonia production change in the years. However, the total cost per year is between 47 and 41 million euros.
- Total revenues per year (€). In the same way that the total cost per year, the total revenues per year is between 63 and 57 million euros.
- CO₂ emission reduction per year (tonnes of CO₂): In the same way that the total cost per year, the CO₂ emission reduction per years is between 238,000 and 211,000.
- Net Present Value (NPV) (€): 4,885,196.
- Pay-Back (PB) (years): 18.15.

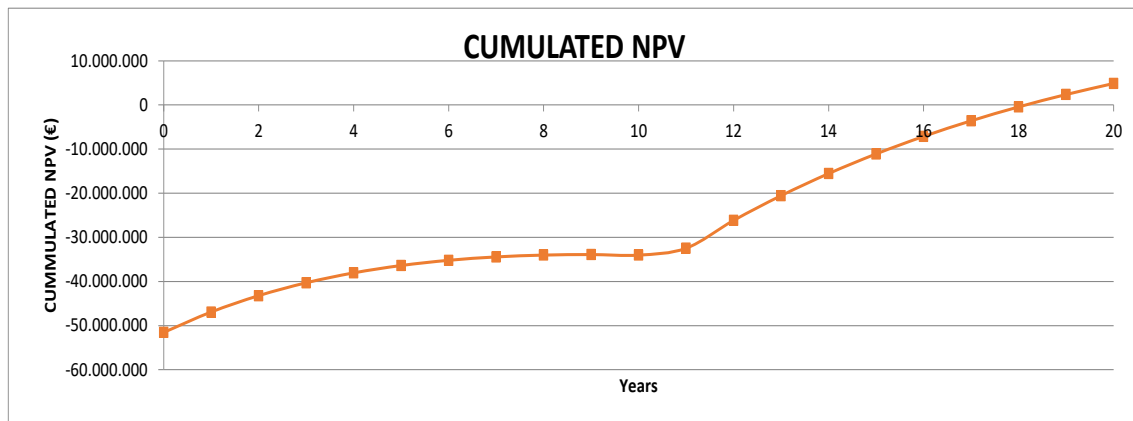

Figure 3: Cumulated Net Present Value VS years.

In order to know how the business case can change when some parameters are changed, some sensitivity analysis is performed. Two of the main parameters are the ammonia sales price (€/tonne) and the CO₂

emission right (€/tonne). The sensitivity analysis will consider for one hand ammonia sales price (€/tonne) from 350 up to 550, and for the other hand CO₂ emission right (€/tonne) from 10 up to 100. The parameter that will be observed in the sensitivity analysis is the Internal Rate of Return (IRR). IRR lower than 10% will be put in white colour and IRR higher than 10% will be put in green colour. All the combinations between ammonia sales price and CO₂ emissions that obtain an IRR higher than 10% (green colour) will be desirable scenarios for the investors (figure 4).

Ammonia production in northern Chile seems a particularly low hanging fruit, due to the existence in the area of a mature solar market, with an excellent resource, interesting wind options, available water desalination technology, better present financial conditions, and large local consumption due to mining, in particular for the direct use in explosives (as well as local consumption of oxygen and heat).

Armijo and Philibert [9] in their study related with green hydrogen and ammonia production in Chile and Argentina estimated near-term production costs for green hydrogen, around 2 USD/kg, and green ammonia, below 500 USD/t, are encouragingly close to competitiveness against fossil-fuel alternatives. In this study the authors consider the best locations in Chile like Taltal and Atacama.

In the figure 5 the ammonia cost in Chile is represented in a period between 2004 and 2018. Following the blue line, it is possible to see the ammonia price when the hydrogen is produced using steam methane reforming (SMR) [10]. The red line is the ammonia price that Armijo and Philibert estimate in their study. Our results show a value of 459.67 €/tonne for the ammonia price which corresponds to more or less 542 USD/tonne, depending on the currency change value between American Dollar and Euro. This value is a little bit higher than the value obtained for Armijo and Philibert. However, the green ammonia production coming from this specific business case is cheaper than the conventional ammonia (with H₂ from SMR) price in 5 of the 14 years represented in the figure 5. The fluctuation in the ammonia cost in Chile depends mainly on the natural gas price and the transport costs.

		AMMONIA SALES PRICE (€/tonne)											
		350	370	390	410	430	450	459,67	470	490	510	530	550
CO2 EMISSION RIGHT PRICE (€/tonne)	10	-11,12%	-7,52%	-4,44%	-1,64%	0,99%	3,53%	4,75%	6,04%	8,56%	11,11%	13,72%	16,41%
	15	-9,01%	-5,74%	-2,84%	-0,15%	2,43%	4,95%	6,16%	7,46%	9,99%	12,57%	15,23%	17,96%
	20	-7,11%	-4,08%	-1,31%	1,31%	3,85%	6,36%	7,57%	8,88%	11,44%	14,06%	16,75%	19,53%
	25	-5,36%	-2,49%	0,18%	2,74%	5,26%	7,77%	9,00%	10,31%	12,90%	15,56%	18,31%	21,14%
	28,5	-4,20%	-1,42%	1,20%	3,74%	6,25%	8,77%	10,00%	11,33%	13,94%	16,63%	19,41%	22,28%
	35	-2,15%	0,50%	3,06%	5,58%	8,09%	10,63%	11,88%	13,23%	15,90%	18,66%	21,50%	24,44%
	40	-0,64%	1,95%	4,48%	6,99%	9,52%	12,09%	13,35%	14,72%	17,44%	20,24%	23,14%	26,13%
	45	0,83%	3,38%	5,89%	8,41%	10,96%	13,56%	14,85%	16,24%	19,01%	21,86%	24,81%	27,85%
	50	2,27%	4,79%	7,30%	9,84%	12,41%	15,06%	16,37%	17,79%	20,60%	23,51%	26,51%	29,59%
	55	3,69%	6,20%	8,72%	11,28%	13,89%	16,58%	17,91%	19,36%	22,23%	25,19%	28,23%	31,37%
	60	5,11%	7,62%	10,16%	12,74%	15,40%	18,13%	19,49%	20,96%	23,88%	26,89%	29,99%	33,16%
	65	6,52%	9,04%	11,60%	14,23%	16,93%	19,71%	21,09%	22,59%	25,56%	28,62%	31,76%	34,98%
	70	7,93%	10,48%	13,07%	15,74%	18,48%	21,32%	22,73%	24,25%	27,27%	30,38%	33,56%	36,82%
	75	9,36%	11,93%	14,56%	17,27%	20,07%	22,96%	24,39%	25,94%	29,01%	32,16%	35,39%	38,68%
	80	10,80%	13,40%	16,08%	18,83%	21,68%	24,63%	26,08%	27,66%	30,77%	33,97%	37,23%	40,55%
	85	12,25%	14,90%	17,62%	20,43%	23,33%	26,32%	27,80%	29,40%	32,56%	35,80%	39,09%	42,45%
90	13,73%	16,42%	19,19%	22,05%	25,00%	28,04%	29,55%	31,17%	34,37%	37,64%	40,97%	44,36%	
95	15,23%	17,96%	20,79%	23,70%	26,70%	29,79%	31,32%	32,96%	36,21%	39,51%	42,87%	46,28%	
100	16,76%	19,54%	22,41%	25,38%	28,43%	31,57%	33,11%	34,78%	38,06%	41,39%	44,78%	48,22%	

Figure 4: Sensitivity analysis between green ammonia sales price and CO₂ emission right price.

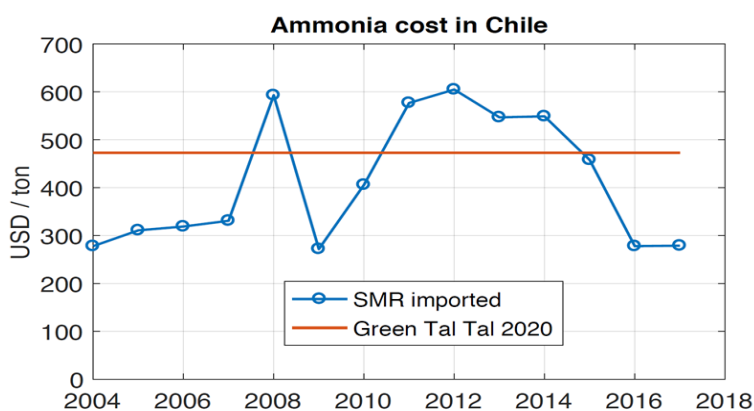

Figure 5: Market costs of ammonia in Chile, compared with Taltal estimate with advanced flexibility at 483 USD/t.

With the Basic Hydrogen Strategy released on December 26, 2017, Japan reiterated its commitment to pioneer the world’s first “Hydrogen Society”. The Strategy primarily aims to achieve the cost parity of hydrogen with competing fuels, such as gasoline in transport and Liquefied Natural Gas (LNG) in power generation.

To this end, the government already six years ago began investing in R&D and providing, including support for low-cost, zero-emission hydrogen production, an expansion of the hydrogen infrastructure for import

and transport abroad within Japan, and an increase of hydrogen use in various areas such as mobility, cogeneration of power and heat, as well as power generation.

However, even in Japan the hydrogen market is not yet economically viable. At present, almost all hydrogen and fuel cell technologies are highly dependent on public funding. The retail price for hydrogen is currently around 100 yen per cubic metre (yen/Nm³). The goal is to reduce it to 30 yen/Nm³ by 2030 and to 20 yen/Nm³ in the long term.

Japan's strategy could have a positive global impact and in particular contribute to the creation of new synergies regarding international energy trading and business cooperation. These will be crucial to drive development and make technologies more affordable.

Japanese companies are already involved in international hydrogen projects such as in Brunei, Norway, and Saudi Arabia. Just recently Kawasaki Heavy Industries also announced the construction of a liquefaction plant, storage facility and loading terminal for hydrogen export to Japan in the Australian state of Victoria as a pilot project for 2020/2021.

The fact that hydrogen is obtained from lignite, as in the case of Australia, does not seem to be of concern. For the Japanese government, the top priority is for hydrogen to become a cheaper energy carrier and thus more attractive for the industry. According to the roadmap of the Japanese Ministry of Economy, Trade and Industry, Japan expects hydrogen technologies to become profitable by 2030. Only afterwards the Japanese government plans to focus more on emission-free hydrogen production.

Australia and Japan share a strong commitment to cooperating on the deployment of hydrogen as a clean, secure, affordable, and sustainable source of energy.

Minister Canavan said Australia and Japan are well placed to maximise the opportunities presented by hydrogen, based on a long history of successful energy and resource trade.

Australia and Japan recognise that hydrogen is a key contributor to reducing emissions, especially when produced from renewable energy or fossil fuels combined with Carbon Capture, Utilisation and Storage (CCUS).

Australia has long been a reliable supplier of energy needs and as global demand for hydrogen continues to grow so does the potential to turn Australia into a major global exporter of hydrogen, particularly to countries such as Japan (see figure 6).

Australia can lead the global shift to green hydrogen or green ammonia:

- Abundant renewable energy potential at low cost. Integral for the development of industrial-scale green hydrogen or green ammonia.
- Strong existing trade links. Well-positioned geographically for the high hydrogen demand economies of Japan, South Korea, China and Singapore;

- Proven track record in industrialising commodity production. At the forefront of natural gas production and trade, with well-developed regulatory, safety and market infrastructure.

The main goal of this business case study is the **production of 300 tonnes per day of green ammonia in order to be storage in an ambient temperature ammonia storage and after transport up to Japan (figure 7)**. In Japan, the ammonia will be used directly or as a hydrogen using an ammonia reformer. However, the business case considers up to the ammonia will be put in Japanese harbour.

In order to produce 300 tonnes per day of green ammonia, storage the ammonia at ambient temperature ammonia storage and after transport the ammonia from Australia to Japan is necessary a facility with the following main equipment:

- 120 MW of alkaline electrolyser (127.2 MW total power supply to the complete electrolysis system and 120 MW total power supply to the electrolyser stack system). This green hydrogen production facility need up to 127.2 MWh of green electricity and 33,424 liters/h of water in order to produce up to 2,335 kg/h of hydrogen (99,95% of purity and 30 bar of pressure), up to 18,591 kg/h of oxygen (98,5% of purity and ambient pressure) and up to 28.8 MWh of thermal energy (temperatures between 60°C and 50°C).
- Low pressure hydrogen storage with 56.5 tonnes of capacity at 30 bar of pressure.
- Hydrogen compression system in order to compress the hydrogen from the low-pressure hydrogen storage up to the Haber-Bosch system. The hydrogen compression system will compress up to 2,355 kg/h of hydrogen from 10 up to 30 bar of pressure.
- Small size Haber-Bosch process in order to produce up to 12.5 tonnes/h of green ammonia. The air will be taken from the air using an Air Separation Unit (ASU). This facility can reach up to 300 tonnes/day of green ammonia. The green ammonia production will be sent directly to an ammonia storage existing in the green ammonia production facility.

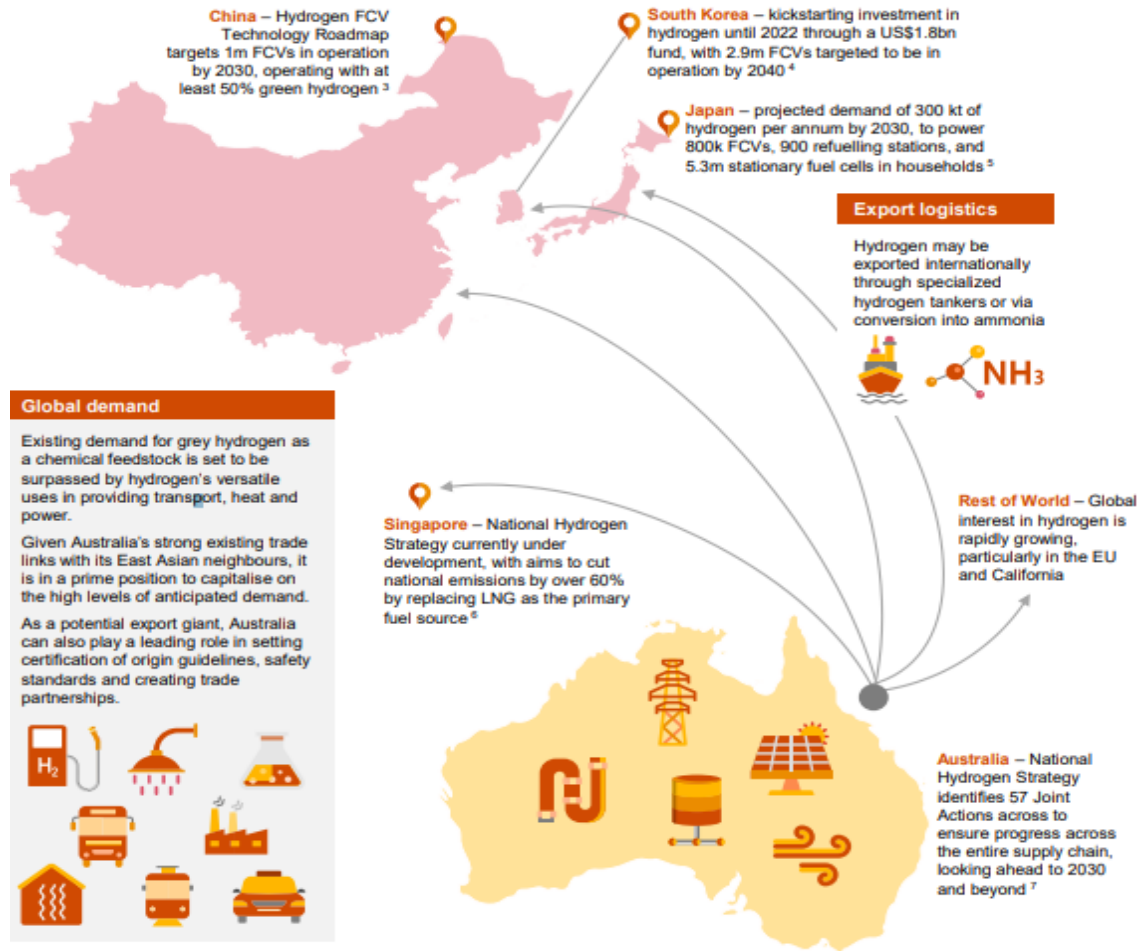

Figure 6: Opportunities to put Australia on the clean hydrogen map exist across the supply chain [11].

- Ambient temperature ammonia storage with the capacity to storage up to 18,000 tonnes of green ammonia. When the storage temperature is ambient, it is needed have a pressure around 18 bar (another option is storage at ambient pressure but in this case will be necessary reduce the ammonia temperature up to -33°C). In order to transport the ammonia from Australia to Japan an ammonia ship will be use and will be fuelled from ambient temperature ammonia storage.

The main goal of the facility is to produce green ammonia and transport from Australia to Japan. However, it is possible use the oxygen as a by-product and also the heat as a by-product due the facility location (industrial area with a lot of industries around).

Each tonne of hydrogen produced via electrolyser with green electricity instead steam methane reforming reduce around 12,1 tonnes of CO₂. In this regard, this facility can reach reduction of the CO₂ emission rights that usually the ammonia facilities need to buy in the market. This means that the facility receives revenues from CO₂ emissions reduction.

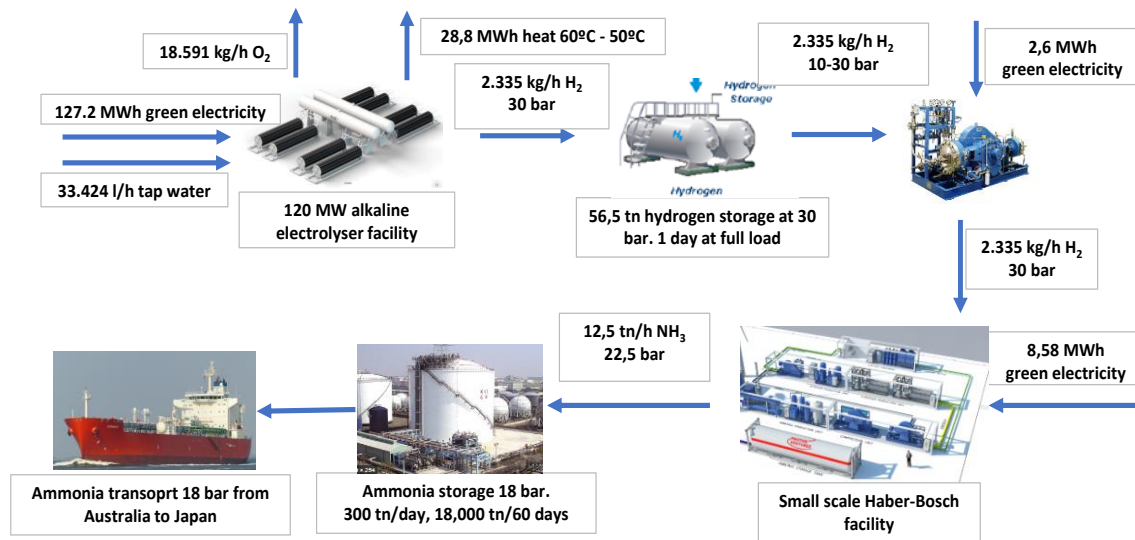

Figure 7: Power to Green Ammonia in order to produce up to 300 tonnes per day and transport from Australia to Japan.

The main technic and economic considerations in order to analyse the price that is necessary put to the green ammonia tonne to reach the 10% of the Internal Rate of Return (IRR) are the following:

- Study period: 20 years.
- Price of green electricity supplied with a Purchase Procurement Agreement (PPA): 36.9 €/MWh [12].
- Tap water cost: 2 € per cubic meter.
- Operation hours per year: 8,000.
- Alkaline electrolyser CAPEX: 600 €/kW.
- Alkaline electrolyser system OPEX (% investment cost per year): 1.5.
- Operation hours up to 10% of stack degradation: 80,000.
- Stack replacement cost (% of the total cost): 20%.
- Low pressure hydrogen storage at 30 bar CAPEX (€/kg): 245.
- Low pressure hydrogen storage system OPEX (% investment cost per year): 0.5.
- Hydrogen compression system from 10 to 30 bar CAPEX (€/kg/h): 2,112.8.
- Hydrogen compression system from 10 to 30 bar OPEX (% investment cost per year): 6.
- Haber-Bosch system CAPEX (€/kW of electrolyser system): 450.
- Haber-Bosch system OPEX (% investment cost per year): 5%.
- Low pressure ammonia storage at 18 bar CAPEX (€/tonne): 800.
- Low pressure ammonia storage system OPEX (% investment cost per year): 0.5.
- Ammonia transport from Australia to Japan (€/tonne): 50.
- Personal cost (€/year): 1,000,000.

- Land rental cost (€/year): 200,000.
- French loan duration: 10 years.
- Finance (% of the total investment): 70.
- Own resources (% of the total investment): 30.
- Financial interest (%): 5.
- Taxes (%): 25.
- Integration cost (piping, electricity, control, safety, etc.,) (% of the main equipment): 12.
- Depreciation (%): 95.
- Depreciation (years): 20.
- Discount rate (%): 7.5.
- Inflation (% per year): 1.5.
- Weighted Average Cost of Capital (WACC) (%): 9.11.
- Oxygen sales price (€/tonne): 30.
- Heat sales price (€/MWh): 15.
- CO₂ avoided emission rights (€/tonne): 28.5.

The main data from this specific business case, taking into account that the goal is fix the ammonia price put in Japanese harbour, in a value that allow us have an Internal Rate or Return of 10% are the following (see picture 8):

- Total investment needed (€): 179,269,763.
- **Ammonia sales price (€/tonne): 583.45.**
- Total cost per year (€). The total cost can be different in the years because the degradation of the electrolyser stack and the degradation of the Haber-Bosch reactor make that the hydrogen and ammonia production change in the years. However, the total cost per year is between 58.5 and 51 million euros.
- Total revenues per year (€). In the same way that the total cost per year, the total revenues per year is between 76 and 69 million euros.
- CO₂ emission reduction per year (tonnes of CO₂): In the same way that the total cost per year, the CO₂ emission reduction per years is between 238,000 and 211,000.
- Net Present Value (NPV) (€): 5,419,864.
- Pay-Back (PB) (years): 18.12.

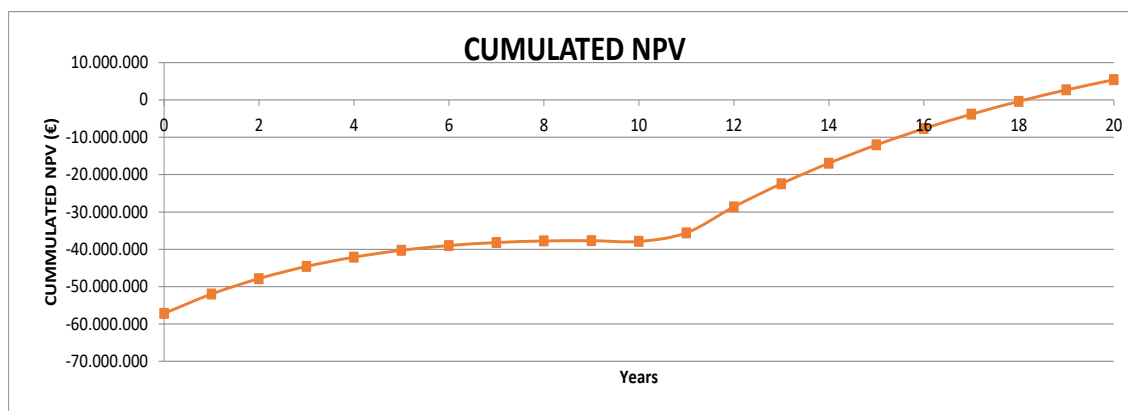

Figure 8: Cumulated Net Present Value VS years.

In order to know how the business case can change when some parameters are changed, some sensitivity analysis will be performed. Two of the main parameters are the ammonia sales price (€/tonne) and the CO₂ emission right (€/tonne). The sensitivity analysis will consider for one hand ammonia sales price (€/tonne) from 400 up to 620, and for the other hand CO₂ emission right (€/tonne) from 10 up to 100. The parameter that will be observed in the sensitivity analysis is the Internal Rate of Return (IRR). IRR lower than 10% will be put in white colour and IRR higher than 10% will be put in green colour. All the combinations between ammonia sales price and CO₂ emissions right that obtain an IRR higher than 10% (green colour) will be desirable scenarios for the investors (figure 8).

		AMMONIA SALES PRICE PUT IN JAPAN											
		400	420	440	460	480	500	520	540	560	580	600	620
CO ₂ EMISSION RIGHT PRICE (€)	10	#jNUM!	#jNUM!	-15,02%	-10,88%	-7,60%	-4,76%	-2,18%	0,24%	2,57%	4,85%	7,13%	9,42%
	15	#jNUM!	#jNUM!	-12,55%	-8,96%	-5,96%	-3,29%	-0,81%	1,56%	3,86%	6,13%	8,41%	10,72%
	20	#jNUM!	-14,43%	-10,43%	-7,22%	-4,43%	-1,87%	0,53%	2,86%	5,14%	7,41%	9,70%	12,03%
	25	-16,63%	-12,05%	-8,56%	-5,61%	-2,97%	-0,51%	1,85%	4,14%	6,42%	8,70%	11,01%	13,36%
	28,5	-14,63%	-10,59%	-7,35%	-4,54%	-1,98%	0,43%	2,76%	5,04%	7,31%	9,60%	11,93%	14,30%
	35	-11,57%	-8,17%	-5,27%	-2,65%	-0,21%	2,14%	4,43%	6,70%	8,99%	11,30%	13,66%	16,08%
	40	-9,58%	-6,49%	-3,77%	-1,26%	1,12%	3,43%	5,71%	7,98%	10,28%	12,62%	15,01%	17,47%
	45	-7,78%	-4,93%	-2,34%	0,09%	2,43%	4,71%	6,99%	9,27%	11,59%	13,96%	16,39%	18,88%
	50	-6,13%	-3,44%	-0,95%	1,41%	3,72%	5,99%	8,27%	10,57%	12,92%	15,32%	17,78%	20,32%
	55	-4,59%	-2,02%	0,39%	2,72%	5,00%	7,27%	9,56%	11,89%	14,26%	16,70%	19,20%	21,78%
	60	-3,12%	-0,65%	1,71%	4,00%	6,28%	8,56%	10,86%	13,22%	15,62%	18,10%	20,64%	23,26%
	65	-1,72%	0,68%	3,00%	5,28%	7,56%	9,85%	12,18%	14,56%	17,01%	19,52%	22,11%	24,77%
	70	-0,35%	2,00%	4,29%	6,56%	8,85%	11,16%	13,51%	15,93%	18,41%	20,97%	23,60%	26,30%
	75	0,98%	3,29%	5,57%	7,84%	10,14%	12,48%	14,87%	17,32%	19,84%	22,44%	25,11%	27,85%
	80	2,29%	4,57%	6,85%	9,13%	11,45%	13,81%	16,24%	18,73%	21,29%	23,93%	26,65%	29,43%
	85	3,58%	5,85%	8,13%	10,43%	12,77%	15,17%	17,63%	20,16%	22,77%	25,45%	28,20%	31,02%
90	4,86%	7,13%	9,42%	11,74%	14,11%	16,55%	19,05%	21,62%	24,27%	26,99%	29,78%	32,64%	
95	6,14%	8,42%	10,72%	13,07%	15,47%	17,94%	20,49%	23,10%	25,79%	28,55%	31,38%	34,27%	
100	7,42%	9,71%	12,04%	14,41%	16,85%	19,36%	21,95%	24,61%	27,34%	30,14%	33,00%	35,92%	

Figure 8: Sensitivity analysis between green ammonia sales price and CO₂ emission right price.

According with the Basic Hydrogen Strategy released on December 26, 2017, the retail market of hydrogen in Japan is currently around 100 yen per normal cubic meter (yen/Nm³), (90 \$ cents/Nm³) and the target

is to reduce it to 30 yen/Nm³ by 2030 (27 \$ cents/Nm³) and to 20 yen/Nm³ (17 \$ cents/Nm³) in the long term.

One green ammonia cubic meter has 121 kg of green hydrogen. The ammonia density is 0.73 kg/m³. This means that one green ammonia tonne has 165.75 kg of green hydrogen. If we divide the green ammonia price obtained in the business case 585.43 €/tonne by the number of kg of green hydrogen per green ammonia tonne, 165.75 kg, each kg of green hydrogen has a cost around 3,53 €/kg or 31.7 € cents/Nm³ or 37 \$ cents/Nm³.

The cost obtained in the specific business case considered in this study is already competitive. It is true that is necessary include more steps like green ammonia reforming in order to obtain green hydrogen and green hydrogen storage. However, the difference between 37 \$ cents/Nm³ and 90 \$ cents/Nm³ allow include the missing steps and the price will continue being competitive.

Specific Business Case 3. Power to Green Hydrogen in Austria

Hydrogen technologies will play an important role in achieving climate neutrality in Austria by 2040. The release of a national hydrogen strategy is expected by the end of 2020 and it will be part of governments policy programme. In particular, hydrogen R&D should take place for applications in industry and mobility sectors, thus strengthening Austria's role in global hydrogen economy. Since 2017, the hydrogen flagship model region Power & Gas – (WIVA P&G) has been established and is one of three flagship regions funded by the Austrian Climate and Energy Fund. WIVA P&G aims to show that Austria is a perfectly suitable region for the switch to a system with green hydrogen. The flagship region combines experience of more than 30 completed and ongoing projects and continuously integrate new projects in the field of hydrogen ensuring the know-how exchange within the WIVA-community and enhance acceptance of hydrogen by general public [13].

For the specific business case area of Linz was chosen. Linz is the capital of Upper Austria and with about 200,000 inhabitants the third largest city in Austria and the second largest metropolitan area in the country with about 800,000 people. In addition, the greater area of Linz is one of the three strongest business locations in Austria due to the energy-intensive industries (mainly steel, chemicals, metal and paper) that are located here. Linz, which is due to its location an important hub for road, rail and shipping traffic, is growing dynamically, which means, that the volume of traffic is also increasing continuously.

Since the European energy supply must be transformed due to energy-related, social, economic, environmental and climatic reasons, the use of hydrogen on the basis of renewable electrical energy can provide one possible solution.

Due to the characteristics like industrial location, traffic junction, gas infrastructure, and well-developed electricity network, the metropolitan Linz area is already and especially in the future an ideal hydrogen hub - H₂Hub_{Linz}. However, there were also other areas in Austria with high future hydrogen demand, which

would be perfectly suited for such a hub.

In this case study H₂Hub_{Linz} a rough concept for the transition towards a renewable energy supply of the industries, transport and heat sector with hydrogen is developed. In the concept of the case study H₂Hub_{Linz} it is planned to build in Linz in the near future (by 2025) a relatively large electrolyser by today's standards, with a nominal electrical power of 100 MW, which would enable economies of scale to be exploited, thereby reducing hydrogen production costs. In Figure 9 there is an overview of H₂Hub_{Linz} with the system boundary and possible consumers of green hydrogen shown.

Now there are already customers for the renewable hydrogen in Linz, although not all of the production of a 100 MW electrolyser can currently be sold in that area. The surplus hydrogen can be transported to other areas due to the good infrastructure (transport hub (truck, ship) and gas grid). The availability of green hydrogen could solve the chicken and egg problem and thus motivate industry and companies to switch to a hydrogen-based system. Subsequently, as the demand for renewable hydrogen increases, more electrolysis plants will be built in Linz. However, the enormous demand for the steel and chemical industry cannot be covered by the production in Linz, which means that, in distant future (2040), the existing infrastructure (gas network, transport hub) will have to be used again, but the other way round, to transport hydrogen to Linz.

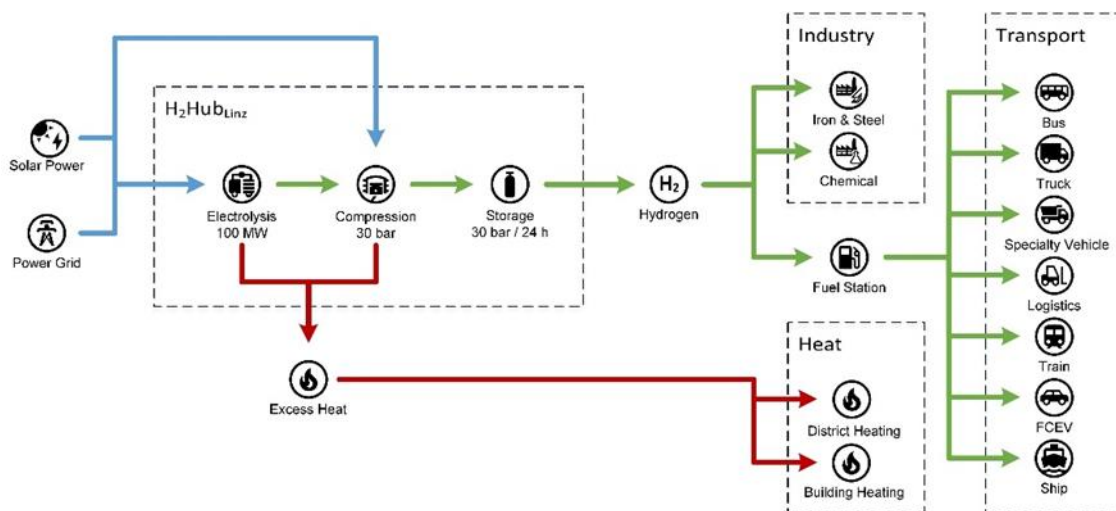

Figure 9: Overview of the case study H₂HubLinz. System boundary of H₂HubLinz plant and possible consumer of the produced green hydrogen.

The main goal of this business case study is the **production of green hydrogen (up to 45 tonnes of green hydrogen per day) to be used in steel and chemical industry and mobility in Linz (figure 10).**

In order to produce up to 45 tonnes per day of green hydrogen to be used in the steel, chemical and mobility industries necessary a facility with the following main equipment:

- 100 MW of PEM electrolyser (106 MW total power supply to the complete electrolysis system and 100 MW total power supply to the electrolyser stack system). This green hydrogen production facility needs a power of up to 106 MW of green electricity and 32,8 liter per hour of water in order to produce up to 1,900 kg/h of hydrogen (99,95% of purity and 30 bar of pressure), up to 15,000 kg/h of oxygen (98,5% of purity and ambient pressure) and up to 24 MW of thermal energy (temperatures about 60°C).
- Hydrogen compression system in order to compress the hydrogen for storage. The hydrogen compression system will compress up to 1,900 kg/h of hydrogen from 10 up to 30 bar.
- Low pressure hydrogen storage with 45 tonnes of capacity at 30 bar.

The main goal of the facility is to produce green hydrogen and use it in the steel, chemical and mobility sector. However, it is also possible to use the oxygen (by-product from the electrolyser) and the excess heat (by-product from the electrolyser and compressor) due the facility location in an industrial area, with a high demand for these by-products.

Each tonne of hydrogen produced via electrolyser with green electricity instead steam methane reforming reduce around 12,1 tonnes of CO₂. In this regard, this facility can reach reduction of the CO₂ emission rights that usually facilities need to buy in the market. This means that the facility receives revenues from CO₂ emissions reduction.

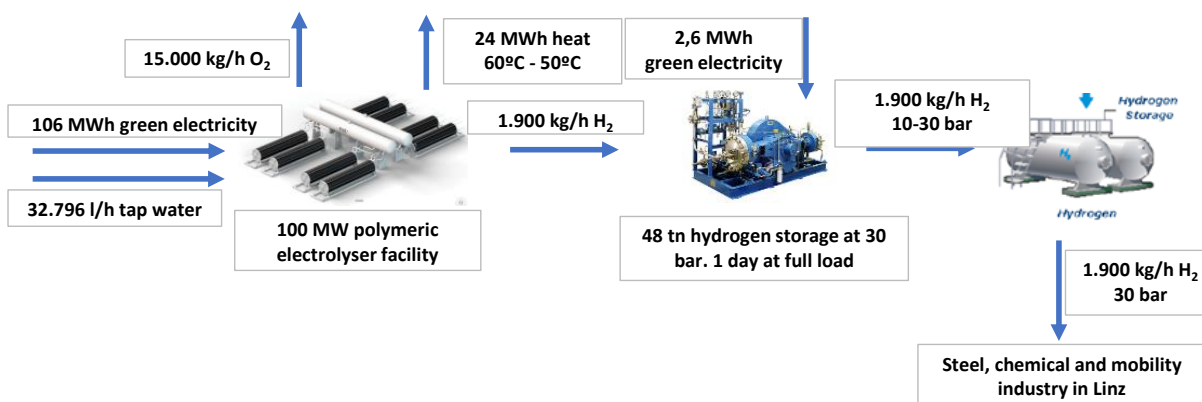

Figure 10: Power to green hydrogen in Austria.

The main technic and economic considerations in order to analyse the price that is necessary put to the green hydrogen tonne to reach the 10% of the Internal Rate of Return (IRR) are the following:

- Study period: 20 years.
- Price of green electricity supplied with a Purchase Procurement Agreement (PPA): 30 €/MWh.
- Tap water cost: 1,15 € per cubic meter.
- Operation hours per year: 6,000.
- PEM electrolyser CAPEX: 800 €/kW.

- PEM electrolyser system OPEX (% investment cost per year): 1.5.
- Operation hours up to 10% of stack degradation: 80,000.
- Stack replacement cost (% of the total cost): 70%.
- Low pressure hydrogen storage at 30 bar CAPEX (€/kg): 245.
- Low pressure hydrogen storage system OPEX (% investment cost per year): 0.5.
- Hydrogen compression system from 10 to 30 bar CAPEX (€/kg/h): 2,112.8.
- Hydrogen compression system from 10 to 30 bar OPEX (% investment cost per year): 6.
- Personal cost (€/year): 1,000,000.
- Land rental cost (€/year): 200,000.
- French loan duration: 10 years.
- Finance (% of the total investment): 70.
- Own resources (% of the total investment): 30.
- Financial interest (%): 4.
- Taxes (%): 25.
- Integration cost (piping, electricity, control, safety, pipes and facilities up to consumers, etc.,) (% of the main equipment): 50.
- Depreciation (%): 95.
- Depreciation (years): 20.
- Discount rate (%): 7.5.
- Inflation (% per year): 1.5.
- Weighted Average Cost of Capital (WACC) (%): 9.11.
- Oxygen sales price (€/tonne): 50.
- Heat sales price (€/MWh): 50.
- CO₂ avoided emission rights (€/tonne): 28.5.

The main data from this specific business case, taking into account that the goal is fix the green hydrogen price in a value that allow us have an Internal Rate or Return of 10% are the following (see picture 11):

- Total investment needed (€): 142,461,781.
- **Green hydrogen sales price (€/kg): 2.13.**
- Total cost per year (€). The total cost can be different in the years because the degradation of the electrolyser stack makes that the hydrogen production change in the years. However, the total cost per year is between 22.3 and 26.3 million euros.
- Total revenues per year (€). In the same way that the total cost per year, the total revenues per year is between 40.1 and 41.4 million euros.
- CO₂ emission reduction per year (tonnes of CO₂): In the same way that the total cost per year, the CO₂ emission reduction per years is between 132,000 and 149,000.
- Net Present Value (NPV) (€): 3,812,821.
- Pay-Back (PB) (years): 18.61.

In order to know how the business case can change when some parameters are changed, a sensitivity analysis will be performed. Two of the main parameters are the green hydrogen sales price (€/tonne) and the CO2 emission right (€/tonne). The sensitivity analysis will consider for one hand green hydrogen sales price (€/tonne) from 1.5 up to 2.6, and for the other hand CO2 emission right (€/tonne) from 10 up to 100. The parameter that will be observed in the sensitivity analysis is the Internal Rate of Return (IRR). IRR lower than 10% will be put in white colour and IRR higher than 10% will be put in green colour. All the combinations between hydrogen sales price and CO2 emissions right that obtain an IRR higher than 10% (green colour) will be desirable scenarios for the investors (figure 12).

Today, neither renewable hydrogen nor fossil-based hydrogen with carbon capture are cost-competitive against fossil-based hydrogen. Current estimated costs for fossil-based hydrogen are around 1.5 €/kg for the EU, highly dependent on natural gas prices, and disregarding the cost of CO2 and costs for fossil-based hydrogen with carbon capture and storage are around 2 €/kg.

That said, costs for renewable hydrogen are going down quickly. Electrolyser costs have already been reduced by 60 % in the last ten years, and are expected to halve in 2030 compared to today with economies of scale if a transition to renewable hydrogen is followed. This presumes that appropriate learning investments in hydrogen and electrolysis are made and innovative hydrogen strategies are implemented as planned. In regions where renewable electricity is cheap, electrolysers are expected to be able to compete with fossil-based hydrogen in 2030. These elements will be key drivers of the progressive development of hydrogen across the EU economy [14].

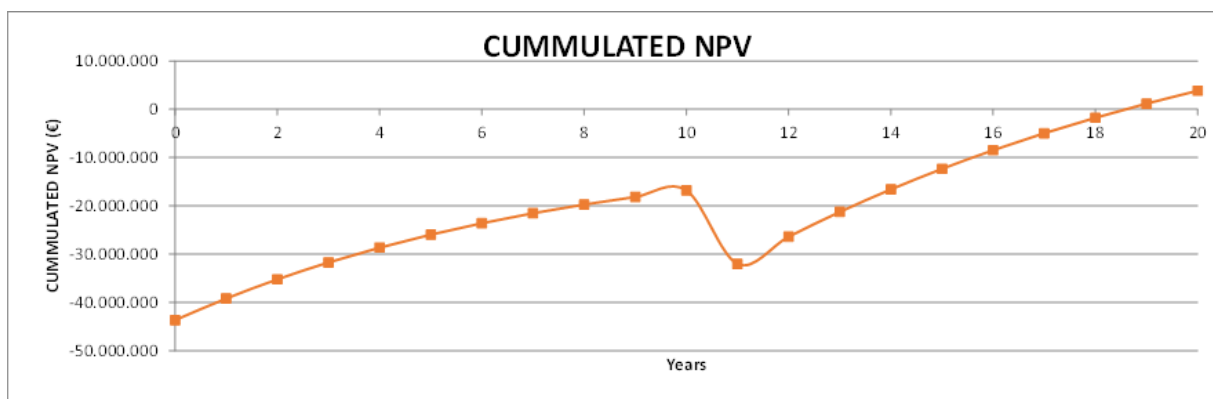

Figure 11: Cumulated Net Present Value VS years.

		GREEN HYDROGEN SALES PRICE (€/kg)											
		1,5	1,6	1,7	1,8	1,9	2,0	2,1	2,2	2,3	2,4	2,5	2,6
CO ₂ PRICE (€)	10	-5,43%	-3,60%	-1,80%	-0,02%	1,76%	3,54%	5,35%	7,19%	9,06%	10,98%	12,94%	14,95%
	15	-4,32%	-2,51%	-0,72%	1,05%	2,84%	4,63%	6,46%	8,32%	10,22%	12,16%	14,15%	16,19%
	20	-3,22%	-1,43%	0,35%	2,13%	3,92%	5,73%	7,58%	9,46%	11,39%	13,36%	15,38%	17,44%
	25	-2,13%	-0,35%	1,43%	3,21%	5,02%	6,85%	8,71%	10,62%	12,57%	14,57%	16,62%	18,72%
	30	-1,05%	0,72%	2,51%	4,30%	6,12%	7,97%	9,86%	11,80%	13,78%	15,81%	17,88%	20,00%
	35	0,02%	1,80%	3,59%	5,40%	7,24%	9,11%	11,03%	12,99%	15,00%	17,06%	19,16%	21,31%
	40	1,10%	2,88%	4,68%	6,51%	8,36%	10,26%	12,21%	14,20%	16,24%	18,32%	20,45%	22,62%
	45	2,18%	3,97%	5,78%	7,63%	9,51%	11,44%	13,41%	15,43%	17,50%	19,61%	21,76%	23,96%
	50	3,26%	5,06%	6,89%	8,76%	10,67%	12,62%	14,62%	16,67%	18,77%	20,91%	23,09%	25,30%
	55	4,35%	6,17%	8,02%	9,91%	11,85%	13,83%	15,86%	17,94%	20,06%	22,22%	24,42%	26,66%
	60	5,44%	7,28%	9,16%	11,08%	13,04%	15,05%	17,11%	19,21%	21,36%	23,55%	25,77%	28,02%
	65	6,55%	8,41%	10,31%	12,26%	14,25%	16,29%	18,38%	20,51%	22,68%	24,89%	27,13%	29,40%
	70	7,67%	9,56%	11,48%	13,46%	15,48%	17,55%	19,66%	21,82%	24,01%	26,24%	28,50%	30,78%
	75	8,81%	10,72%	12,67%	14,67%	16,72%	18,82%	20,96%	23,14%	25,36%	27,60%	29,88%	32,18%
	80	9,96%	11,89%	13,88%	15,91%	17,99%	20,11%	22,27%	24,48%	26,71%	28,98%	31,27%	33,58%
	85	11,12%	13,09%	15,10%	17,16%	19,27%	21,42%	23,60%	25,83%	28,08%	30,36%	32,66%	34,98%
90	12,31%	14,30%	16,34%	18,43%	20,56%	22,73%	24,94%	27,19%	29,46%	31,75%	34,06%	36,40%	
95	13,51%	15,53%	17,60%	19,71%	21,87%	24,07%	26,30%	28,56%	30,84%	33,15%	35,47%	37,82%	
100	14,73%	16,78%	18,87%	21,01%	23,20%	25,41%	27,66%	29,94%	32,23%	34,55%	36,89%	39,24%	

Figure 12: Sensitivity analysis between green hydrogen sales price and CO₂ emission right price.

Specific Business Case 4. Power to Green Hydrogen from Patagonia to Japan

From a global point of view the spatial offer of renewable energy sources like wind and solar power differs significantly. Due to regions of renewable energy surplus on the one hand and regions with high energy demands on the other, a worldwide assessment is required that examines the economical performance of hydrogen provision schemes based on renewable energy sources and evaluates potential trading connections.

Having the third biggest economy worldwide Japan's demand for energy was the fifth biggest worldwide in the year 2016. In 2015 Japan's total primary energy supply consisted of fossil fuels to more than 93%. Since Japan has very limited mineral resources available it was and yet is highly dependent on the import of fossil fuels, especially crude oil and natural gas. Only about 10% of the total primary energy consumption was produced domestically in 2015. Prior to 2011, Japan was generating around 30% of its electricity by using nuclear power. The government planned on extending this to 60% for purposes of emission reduction. However, due to the 2011's Great East Japan Earthquake, nuclear power plants have been shut down and Japan decided to reduce the role of nuclear power in its energy portfolio. With regard to fossil fuels Japan depends on overseas imports for about 94% of its primary energy supply. 98% of oil-based fuels are used in the mobility sector, thereof 87% are imported from the Middle East. As a result, Japan had the second lowest self-sufficiency among the OECD countries in 2013 with 6-7%.

Compared to 2013 Japan strives to cut 26% of its CO₂ emissions by 2030 and, in accordance with the COP 21 Agreement, the emissions are to be reduced by 80% by 2050. In 2015 the share of renewable energy sources amounted to less than 6% of the total primary energy sources in Japan. Hence, despite the Japanese trend of promoting the expansion of renewable energy sources the corresponding domestic production is lacking the potential to cover the country's prospective demand for emission free energy. Taking into consideration its goals of emission reduction and the catastrophic nuclear accident at the Fukushima Daiichi Nuclear Power Plant in March 2011 the Japanese government strives for the sustainable implementation of an emission free “hydrogen society” by 2020 in which hydrogen will be the primary energy medium.

Despite the recent trend of expanding the renewable energy sources utilization, the Japanese transport sector still depends heavily on fossil fuel, mostly imported oil derivatives. For purposes of replacement oil derivatives in the transportation sector to meet the emission reduction goals the import of emission free hydrogen from overseas is considered to be an attractive energy supply option. In its “Basic Hydrogen Strategy 2017” the Ministry of Economy, Trade and Industry states that realizing a hydrogen-based society requires international hydrogen supply chains to ensure a reasonable and secure provision with CO₂ free hydrogen.

Unlike Japan, numerous countries or regions, respectively, are characterized by a high renewable energy sources potential while having a relatively low domestic energy demand at the same time. Among various other regions all over the world, Argentina's Patagonia shows a considerable wind potential. Characterized by average full-load hours between 4100 and 5200, Patagonia's estimated wind energy potential of ~ 9600 TWh is about ten times higher than the total Japanese demand for electricity of 995.26 TWh. At the same time Argentina shows an electricity demand of only 131.20 TWh. Hence, exporting a significant part of the potentially producible renewable electricity could be exported without jeopardizing a hypothetical Argentinian domestic electricity supply based only on renewable energy sources. Therefore, an attractive opportunity exists in which Patagonian wind power generation acts as a hydrogen source for Japan's energy economy.

The conversion of renewable energy sources based electricity to hydrogen and the subsequent domestic and overseas transport requires a detailed analysis of the entire supply chain. This supply chain comprises wind energy conversion, water electrolysis, a domestic pipeline transmission system, installations to liquefy and store the hydrogen, and finally special carriers for the overseas transport of liquefied hydrogen. Besides the technical feasibility the total costs of the system are of great interest to determine the specific costs for providing hydrogen to Japan.

The main goal of this business case study is the **production up to 48 tonnes per day of green hydrogen and transport from Argentina to Japan (figure 13).**

In order to produce up to 48 tonnes per day of green hydrogen is necessary a facility with the following main equipment:

- 100 MW of alkaline electrolyser (106 MW total power supply to the complete electrolysis system and 100 MW total power supply to the electrolyser stack system). This green hydrogen production facility need up to 106 MWh of green electricity and 26,666 liters/h of water in order to produce up to 2,000 kg/h of hydrogen (99,95% of purity and 30 bar of pressure), up to 16,000 kg/h of oxygen (98,5% of purity and ambient pressure) and up to 24 MWh of thermal energy (temperatures between 60°C and 50°C).
- Low pressure hydrogen storage with 48 tonnes of capacity at 30 bar of pressure.
- Hydrogen compression system in order to compress the hydrogen from the low-pressure hydrogen storage up to the liquefaction of liquid organic hydrogen carriers. The hydrogen compression system will compress up to 2,000 kg/h of hydrogen from 10 up to 30 bar of pressure.

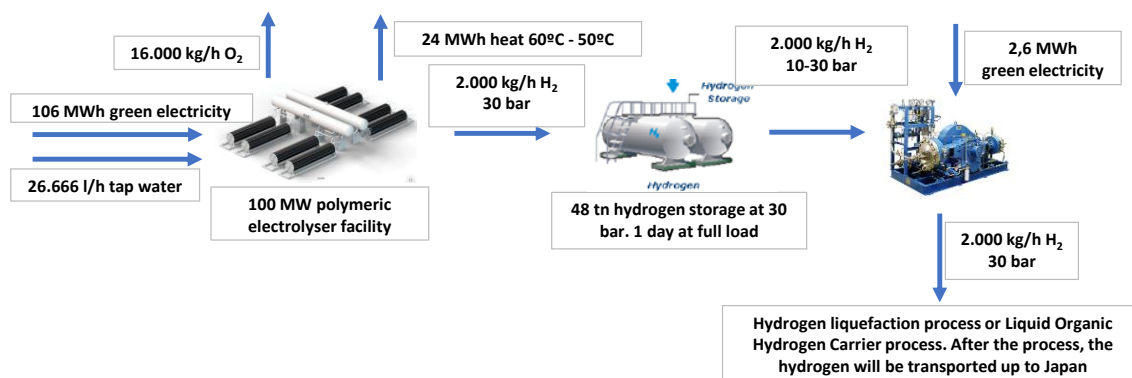

Figure 13: Power to Green hydrogen in order to produce up to 48 tonnes per day.

In this business case, we will consider two options in order to adapt the hydrogen in order to be transported from Argentina to Japan. These two options are a) liquid hydrogen and b) liquid organic hydrogen carriers. In both cases, the liquefaction facility or the hydrogenation facility will be not considered as an investment. The business case considers that we will be paid for the conversion system (compress hydrogen to liquid hydrogen or compress hydrogen to liquid organic hydrogen carrier), storage (liquid or liquid organic hydrogen carrier) and transport (in both cases in liquid but in cryogenic transport when we are talking about liquid hydrogen and in a conventional transport when we are talking about liquid organics hydrogen carrier).

The main goal of the facility is to produce green hydrogen. However, it is possible to use the oxygen as a by-product due to the facility location (industrial area with a lot of industries around). In this business case, the heat will not be used.

Each tonne of hydrogen produced via electrolyser with green electricity instead of steam methane reforming reduces around 12,1 tonnes of CO₂. In this regard, this facility can reach a reduction of the CO₂ emissions rights that usually the hydrogen facilities need to buy in the market. This means that the facility receives revenues from CO₂ emissions reduction.

The main technic and economic considerations in order to analyse the price that is necessary put to the green hydrogen tonne in liquid form from Argentina to Japan in order to reach the 10% of the Internal Rate of Return (IRR) are the following:

- Study period: 20 years.
- Price of green electricity supplied with a Purchase Procurement Agreement (PPA): 32 €/MWh.
- Tap water cost: 1.05 € per cubic meter.
- Operation hours per year: 8,000.
- Alkaline electrolyser CAPEX: 600 €/kW.
- Alkaline electrolyser system OPEX (% investment cost per year): 1.5.
- Operation hours up to 10% of stack degradation: 80,000.
- Stack replacement cost (% of the total cost): 20%.
- Low pressure hydrogen storage at 30 bar CAPEX (€/kg): 175.
- Low pressure hydrogen storage system OPEX (% investment cost per year): 0.5.
- Hydrogen compression system from 10 to 30 bar CAPEX (€/kg/h): 2,112.8.
- Hydrogen compression system from 10 to 30 bar OPEX (% investment cost per year): 6.
- Cost of hydrogen conversion from compress form to liquid form (€/kg): 1.60.
- Cost of liquid hydrogen storage (€/kg): 0.18.
- Cost of liquid hydrogen transport (€/kg): 1.10.
- Personal cost (€/year): 1,000,000.
- Land rental cost (€/year): 250,000.
- French loan duration: 10 years.
- Finance (% of the total investment): 70.
- Own resources (% of the total investment): 30.
- Financial interest (%): 5.
- Taxes (%): 25.
- Integration cost (piping, electricity, control, safety, etc.,) (% of the main equipment): 12.
- Depreciation (%): 90.
- Depreciation (years): 20.
- Discount rate (%): 7.5.
- Inflation (% per year): 1.5.
- Weighted Average Cost of Capital (WACC) (%): 9.11.
- Oxygen sales price (€/tonne): 30.
- CO2 avoided emission rights (€/tonne): 28.5.

The main data from this specific business case, taking into account that the goal is fix the green liquid hydrogen price in a value that allow us have an Internal Rate or Return of 10% are the following (see picture 14):

- Total investment needed (€): 93,329,369.

- **Green hydrogen sales price in liquid form (€/kg): 4.98.**
- Total cost per year (€). The total cost can be different in the years because the degradation of the electrolyser stack makes that the green hydrogen production change in the years. However, the total cost per year is between 78 and 69.6 million euros.
- Total revenues per year (€). In the same way that the total cost per year, the total revenues per year is between 87.6 and 77 million euros.
- CO₂ emission reduction per year (tonnes of CO₂): In the same way that the total cost per year, the CO₂ emission reduction per years is between 147,300 and 129,500.
- Net Present Value (NPV) (€): 2,619,758.
- Pay-Back (PB) (years): 18.60.

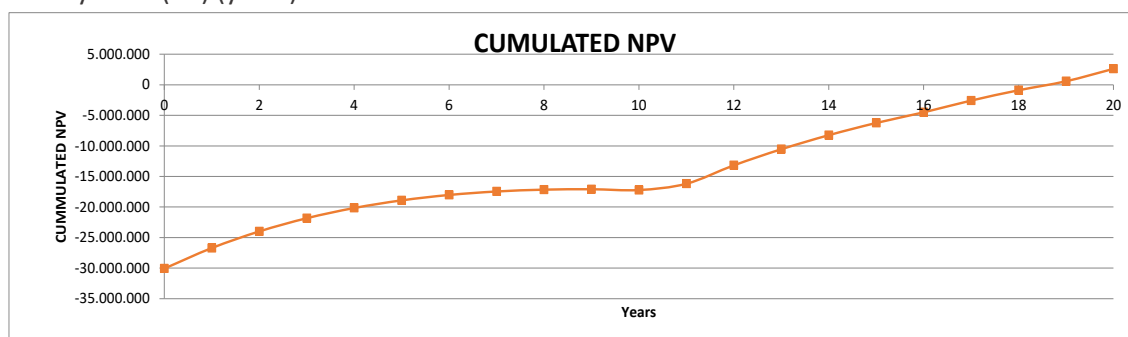

Figure 14: Cumulated Net Present Value VS years.

In order to know how the business case can change when some parameters are changed, some sensitivity analysis will be performed. Two of the main parameters are the green liquid hydrogen sales price (€/tonne) and the CO₂ emission right (€/tonne). The sensitivity analysis will consider for one hand green liquid hydrogen sales price (€/tonne) from 4.3 up to 5.4, and for the other hand CO₂ emission right (€/tonne) from 10 up to 100. The parameter that will be observed in the sensitivity analysis is the Internal Rate of Return (IRR). IRR lower than 10% will be put in white colour and IRR higher than 10% will be put in green colour. All the combinations between green liquid hydrogen sales price and CO₂ emissions right that obtain an IRR higher than 10% (green colour) will be desirable scenarios for the investors (figure 15).

The main technic and economic considerations in order to analyse the price that is necessary put to the green hydrogen tonne in liquid organic hydrogen carrier form from Argentina to Japan in order to reach the 10% of the Internal Rate of Return (IRR) are the following:

- Study period: 20 years.
- Price of green electricity supplied with a Purchase Procurement Agreement (PPA): 32 €/MWh.
- Tap water cost: 1.05 € per cubic meter.
- Operation hours per year: 8,000.
- Alkaline electrolyser CAPEX: 600 €/kW.
- Alkaline electrolyser system OPEX (% investment cost per year): 1.5.

- Operation hours up to 10% of stack degradation: 80,000.
- Stack replacement cost (% of the total cost): 20%.
- Low pressure hydrogen storage at 30 bar CAPEX (€/kg): 175.
- Low pressure hydrogen storage system OPEX (% investment cost per year): 0.5.
- Hydrogen compression system from 10 to 30 bar CAPEX (€/kg/h): 2,112.8.
- Hydrogen compression system from 10 to 30 bar OPEX (% investment cost per year): 6.
- Cost of hydrogen conversion from compress form to liquid organic hydrogen carrier form (€/kg): 0.80.
- Cost of liquid organic hydrogen carrier storage (€/kg): 0.12.
- Cost of liquid organic hydrogen transport (€/kg): 0.88.
- Personal cost (€/year): 1,000,000.
- Land rental cost (€/year): 250,000.
- French loan duration: 10 years.
- Finance (% of the total investment): 70.
- Own resources (% of the total investment): 30.
- Financial interest (%): 5.
- Taxes (%): 25.
- Integration cost (piping, electricity, control, safety, etc.,) (% of the main equipment): 12.
- Depreciation (%): 90.
- Depreciation (years): 20.
- Discount rate (%): 7.5.
- Inflation (% per year): 1.5.
- Weighted Average Cost of Capital (WACC) (%): 9.11.
- Oxygen sales price (€/tonne): 30.
- CO2 avoided emission rights (€/tonne): 28.5.

		GREEN LIQUID HYDROGEN SALES PRICE											
		4,3	4,4	4,5	4,6	4,7	4,8	4,9	5	5,1	5,2	5,3	5,4
CO ₂ EMISSION RIGHT PRICE (€)	10	#iNUM!	#iNUM!	#iNUM!	-11,04%	-6,51%	-2,54%	1,15%	4,71%	8,26%	11,87%	15,58%	19,42%
	15	#iNUM!	#iNUM!	-13,90%	-8,86%	-4,63%	-0,82%	2,80%	6,34%	9,91%	13,56%	17,33%	21,23%
	20	#iNUM!	#iNUM!	-11,44%	-6,84%	-2,84%	0,86%	4,43%	7,98%	11,58%	15,28%	19,11%	23,08%
	25	#iNUM!	-14,35%	-9,22%	-4,94%	-1,11%	2,52%	6,07%	9,63%	13,27%	17,03%	20,92%	24,95%
	28,5	#iNUM!	-12,56%	-7,77%	-3,67%	0,08%	3,66%	7,21%	10,80%	14,47%	18,27%	22,21%	26,27%
	35	-14,80%	-9,58%	-5,26%	-1,40%	2,24%	5,79%	9,35%	12,98%	16,73%	20,61%	24,63%	28,77%
	40	-12,24%	-7,51%	-3,44%	0,29%	3,88%	7,42%	11,01%	14,69%	18,50%	22,44%	26,52%	30,72%
	45	-9,95%	-5,58%	-1,69%	1,95%	5,51%	9,07%	12,69%	16,43%	20,30%	24,31%	28,44%	32,69%
	50	-7,85%	-3,75%	0,01%	3,60%	7,14%	10,73%	14,40%	18,20%	22,13%	26,20%	30,38%	34,68%
	55	-5,90%	-1,99%	1,67%	5,23%	8,79%	12,41%	16,13%	19,99%	23,99%	28,11%	32,35%	36,69%
	60	-4,05%	-0,28%	3,32%	6,86%	10,44%	14,11%	17,89%	21,82%	25,87%	30,05%	34,34%	38,71%
	65	-2,28%	1,39%	4,95%	8,51%	12,12%	15,84%	19,68%	23,67%	27,78%	32,01%	36,34%	40,75%
	70	-0,57%	3,04%	6,59%	10,16%	13,82%	17,59%	21,50%	25,55%	29,72%	34,00%	38,37%	42,81%
	75	1,11%	4,67%	8,23%	11,83%	15,54%	19,38%	23,35%	27,46%	31,68%	36,00%	40,41%	44,88%
	80	2,76%	6,31%	9,88%	13,53%	17,29%	21,19%	25,23%	29,39%	33,66%	38,02%	42,46%	46,96%
	85	4,40%	7,95%	11,55%	15,24%	19,07%	23,03%	27,13%	31,34%	35,66%	40,06%	44,53%	49,06%
	90	6,03%	9,59%	13,24%	16,99%	20,88%	24,91%	29,06%	33,32%	37,68%	42,11%	46,61%	51,16%
95	7,67%	11,26%	14,95%	18,77%	22,72%	26,80%	31,01%	35,32%	39,71%	44,17%	48,70%	53,28%	
100	9,31%	12,95%	16,69%	20,57%	24,58%	28,73%	32,98%	37,33%	41,76%	46,25%	50,80%	55,40%	

Figure 15: Sensitivity analysis between green liquid hydrogen sales price and CO₂ emission right price.

The main data from this specific business case, taking into account that the goal is fix the green hydrogen price in a value that allow us to have an Internal Rate or Return of 10% are the following (see picture 16):

- Total investment needed (€): 93,329,369.
- **Green hydrogen sales price in liquid organic hydrogen carrier form (€/kg): 3.89.**
- Total cost per year (€). The total cost can be different in the years because the degradation of the electrolyser stack makes that the green hydrogen production change in the years. However, the total cost per year is between 60.4 and 54.4 million euros.
- Total revenues per year (€). In the same way that the total cost per year, the total revenues per year is between 70 and 61.6 million euros.
- CO₂ emission reduction per year (tonnes of CO₂): In the same way that the total cost per year, the CO₂ emission reduction per years is between 147,300 and 129,500.
- Net Present Value (NPV) (€): 2,513,330.
- Pay-Back (PB) (years): 18.52.

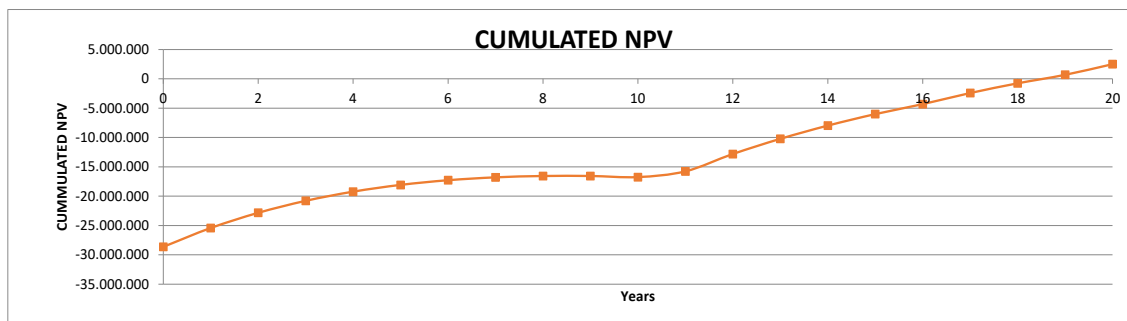

Figure 16: Cumulated Net Present Value VS years.

In order to know how the business case can change when some parameters are changed, some sensitivity analysis will be performed. Two of the main parameters are the green liquid organic hydrogen carrier sales price (€/tonne) and the CO₂ emission right (€/tonne). The sensitivity analysis will consider for one hand green liquid organic hydrogen carrier sales price (€/tonne) from 3.3 up to 4.4, and for the other hand CO₂ emission right (€/tonne) from 10 up to 100. The parameter that will be observed in the sensitivity analysis is the Internal Rate of Return (IRR). IRR lower than 10% will be put in white colour and IRR higher than 10% will be put in green colour. All the combinations between green liquid organic hydrogen carrier sales price and CO₂ emissions right that obtain an IRR higher than 10% (green colour) will be desirable scenarios for the investors (figure 17).

		GREEN LIQUID ORGANIC HYDROGEN CARRIER SALES PRICE											
		3,3	3,4	3,5	3,6	3,7	3,8	3,9	4	4,1	4,2	4,3	4,4
CO ₂ EMISSION RIGHT PRICE (€)	10	#jNUM!	#jNUM!	-12,68%	-7,65%	-3,39%	0,50%	4,22%	7,92%	11,68%	15,55%	19,56%	23,74%
	15	#jNUM!	-16,00%	-10,23%	-5,62%	-1,56%	2,23%	5,92%	9,64%	13,44%	17,38%	21,47%	25,71%
	20	#jNUM!	-13,13%	-8,01%	-3,70%	0,20%	3,93%	7,63%	11,38%	15,24%	19,24%	23,40%	27,71%
	25	#jNUM!	-10,63%	-5,95%	-1,87%	1,93%	5,63%	9,35%	13,14%	17,06%	21,14%	25,37%	29,74%
	30	-13,59%	-8,37%	-4,02%	-0,10%	3,64%	7,34%	11,08%	14,93%	18,92%	23,07%	27,37%	31,80%
	35	-11,03%	-6,29%	-2,18%	1,64%	5,35%	9,05%	12,84%	16,75%	20,82%	25,03%	29,40%	33,88%
	40	-8,74%	-4,34%	-0,40%	3,35%	7,05%	10,78%	14,62%	18,60%	22,74%	27,03%	31,45%	35,98%
	45	-6,64%	-2,49%	1,35%	5,06%	8,76%	12,54%	16,44%	20,49%	24,70%	29,05%	33,53%	38,11%
	50	-4,67%	-0,70%	3,06%	6,76%	10,49%	14,32%	18,29%	22,41%	26,68%	31,10%	35,62%	40,25%
	55	-2,80%	1,05%	4,77%	8,47%	12,24%	16,13%	20,17%	24,36%	28,70%	33,17%	37,74%	42,41%
	60	-1,00%	2,77%	6,47%	10,19%	14,01%	17,97%	22,08%	26,34%	30,75%	35,27%	39,88%	44,58%
	65	0,76%	4,48%	8,17%	11,94%	15,82%	19,84%	24,03%	28,36%	32,81%	37,38%	42,04%	46,77%
	70	2,48%	6,18%	9,90%	13,71%	17,65%	21,75%	26,00%	30,40%	34,91%	39,52%	44,21%	48,97%
	75	4,19%	7,88%	11,64%	15,51%	19,52%	23,69%	28,01%	32,46%	37,02%	41,67%	46,39%	51,18%
	80	5,89%	9,60%	13,40%	17,34%	21,42%	25,66%	30,05%	34,55%	39,15%	43,84%	48,59%	53,40%
	85	7,59%	11,34%	15,20%	19,20%	23,36%	27,67%	32,11%	36,66%	41,30%	46,02%	50,80%	55,63%
90	9,31%	13,10%	17,02%	21,10%	25,33%	29,70%	34,19%	38,79%	43,47%	48,21%	53,02%	57,88%	
95	11,04%	14,89%	18,88%	23,03%	27,32%	31,75%	36,30%	40,93%	45,65%	50,42%	55,25%	60,13%	
100	12,80%	16,71%	20,77%	24,99%	29,35%	33,83%	38,42%	43,10%	47,84%	52,64%	57,50%	62,40%	

Figure 15: Sensitivity analysis between green liquid hydrogen sales price and CO₂ emission right price.

By implementing a hydrogen society, Japan aims for several objectives. Firstly, hydrogen from different sources, but especially from different renewable energy sources, reduces supply risks. Secondly, by using

hydrogen no CO₂ is emitted during the energy conversion reaction. And lastly, the government sees economic competitiveness potential in being the first nation to implement a hydrogen society.

In general, literature sources assume an increasing demand for hydrogen over the coming decades. According to the Japanese government's Basic Hydrogen Strategy, the demand for hydrogen is supposed to be 4,000 tH₂/a in 2020; 300,000 tH₂/a in 2030, and around 5 to 10 million tH₂/a in 2050. The New Energy and Industrial Technology Development Organization (NEDO) estimated the prospective Japanese hydrogen demand to be 314,300 tH₂/a in 2020 and 10.6 million tH₂/a in 2050.

According with the Basic Hydrogen Strategy, the retail market of hydrogen in Japan is currently around 100 yen per normal cubic meter (yen/Nm³), (90 \$ cents/Nm³) and the target is to reduce it to 30 yen/Nm³ by 2030 (27 \$ cents/Nm³) and to 20 yen/Nm³ (17 \$ cents/Nm³) in the long term.

The cost obtained in the specific business case considered in this study for green liquid hydrogen (4.98 €/kg or 44.7 € cents/Nm³ or 38.05 \$ cents/Nm³) and for green liquid organic hydrogen carrier (3.89 €/kg or 34.9 € cents/Nm³ or 29.7 \$ cents/Nm³) are already competitive. It is true that is necessary include more steps like gasification process or dehydrogenation process, land transport, etc. However, the difference between 38.08 \$ cents/Nm³ or 29.7 \$ cents/Nm³ and 90 \$ cents/Nm³ allow include the missing steps and the price will continue being competitive.

Philipp-Matthias et al [15] in the paper Flexible production of green hydrogen and ammonia from variable solar and wind energy. Case study of Chile and Argentina, the development of levelized cost of hydrogen across the supply chain will be obtained, with a provision costs of 4.44 €/kgH₂ at a liquid state in the harbour of Yokohama. The biggest shares are contributed by the electricity (1.22 €/kgH₂), the electrolysis (0.94 €/kgH₂), and the ship transport (1.13 €/kgH₂). Fig. 16 shows how the final green liquid hydrogen in the harbour of Yokohama result on the left side. The right side gives the cost distribution for each supply chain element. The figures obtained in this study is so close to the results obtained in this business case.

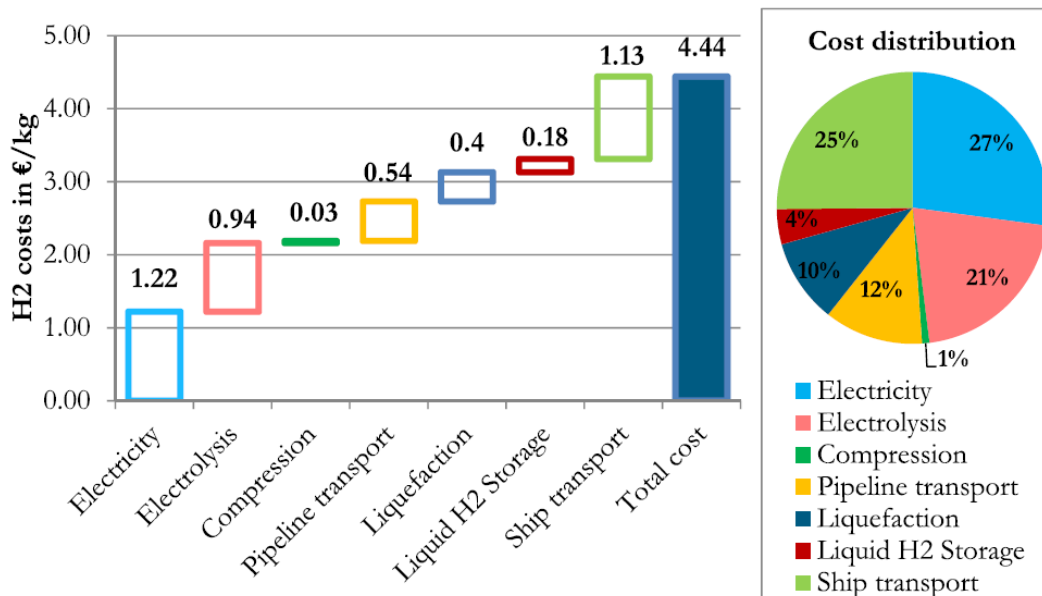

Figure 16: Overview over the green liquid hydrogen cost contributions by each hydrogen supply chain element.

Specific Business Case 5. Power to Hydrogen with Waste CO₂ from Green Methanol in China

Road transport consumes around 33% of total energy consumption by transport [16]. Petroleum fuels are the primary fuels of road transportation. Their burning results in harmful emissions including carbon dioxide emissions. According to the International Energy Agency (IEA) carbon dioxide emissions are increasing. In 2018, their value exceeded 33 Gt [17]. To mitigate climate change, the United Nations Intergovernmental Panel on Climate Change recommended reduction of greenhouse gas emissions by 50–85% by 2050. The decrease of harmful emissions can be reached by using alternative vehicle fuels, including methanol.

Methanol could bring economic and ecological benefits to China. This fuel is environmentally friendly. Moreover, its application results in reduced fuel costs. China imports around 65% oil and 31% natural gas. The use of methanol-based fuel can decrease the import of the above Energy resources. Since 2000, the Chinese government has improved national energy independence and cut harmful emissions. Therefore, the increase of the methanol vehicle fleet ensures the sustainable economic growth of the country.

Methanol is mainly converted into the following fuels: neat methanol M100; methanol and petrol blend (M5, M10, M15, M30, M50 and M85); methanol-based petrol; methyl tertiary butyl ether (MTBE); dimethyl ether (DME); and biodiesel. Methanol can be converted to different hydrocarbons, including olefins. Olefins are valuable raw materials for the production of liquid vehicle fuels such as gasoline, distillate and dimethyl ether.

In 2018, road transport in China consumed 126 million tons of petrol and 156 million tons of diesel fuel. Meanwhile, methanol consumption was around 17.4 million tons. The production and use of methanol is growing mainly due to the use of methanol by transport in China (Figures 17 and 18) [18,19].

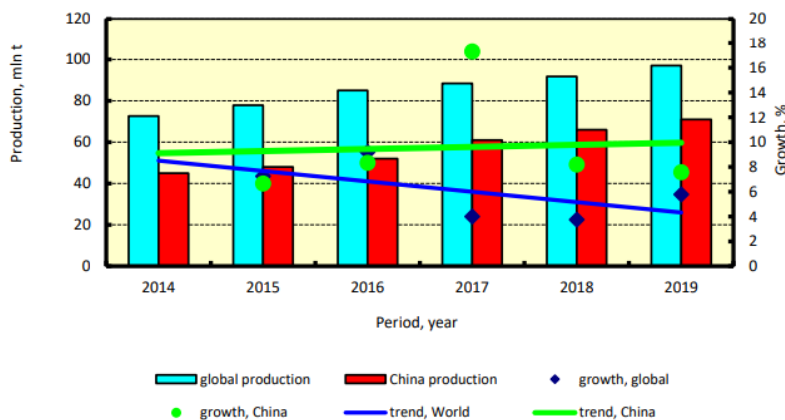

Figure 17: Global and China methanol production.

The largest methanol producer in the world is China (around 70 million tons) [18,19]. Other countries produced much less methanol. For example, in 2018 the USA produced 5.7 million tons and Russia produced 4.46 million tons [20,21]. Methanol is an important chemical. It is used mainly in Asia, and China is the largest methanol consumer. Methanol usage by region of the world is as follows, in percent: China 58%; the rest of Asia-Pacific 16%; Europe 13%; Latin America 2%; North America 10% [22].

The growth of methanol production in China has had a positive trend despite global methanol production growth having slowed. There has been an increase in methanol-based fuel consumption (Figure 18).

Green methanol is very attractive for the energy sector. It makes possible the development of the methanol economy. The transition to the methanol economy may allow China to reach the following results: strengthening of energy security; reduction of air pollution and carbon dioxide emissions; and increases in the added value of the domestic economy. Therefore, the methanol economy gives tangible benefits.

The main goal of this business case study is the **production of 344 tonnes per day of green methanol in order to be used as a fuel in the transport sector, as an energy carrier and as a feedstock for chemical process in China (figure 19).**

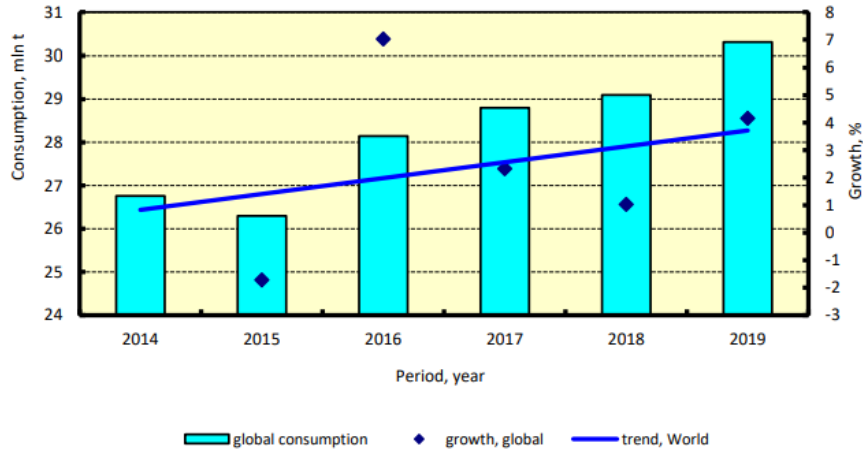

Figure 18: Global methanol consumption as fuel.

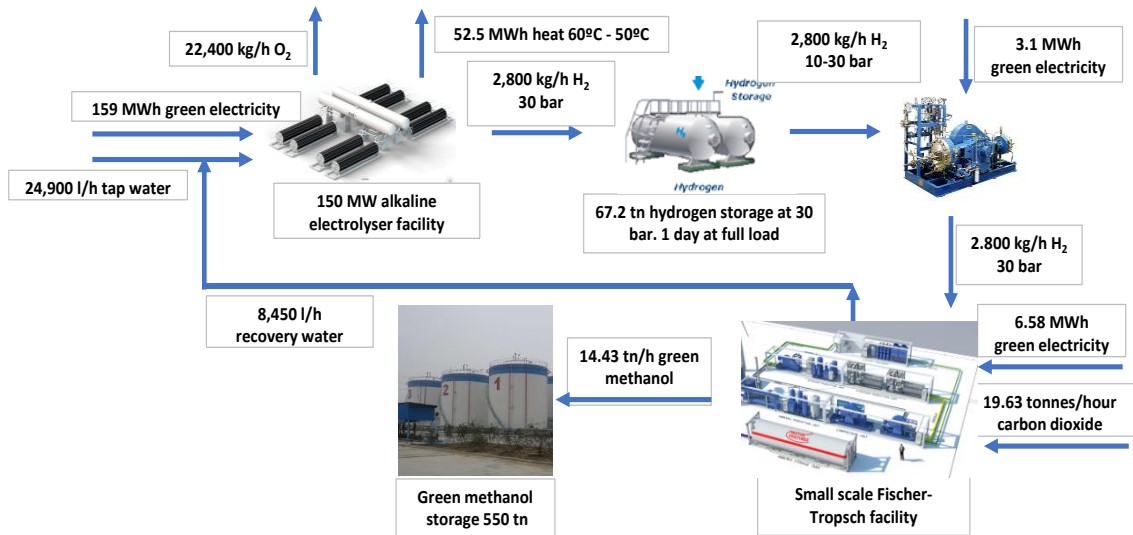

Figure 19: Power to Green methanol in order to produce up to 344 tonnes per day.

In order to produce 344 tonnes per day of green methanol is necessary a facility with the following main equipment:

- 150 MW of alkaline electrolyser (159 MW total power supply to the complete electrolysis system and 150 MW total power supply to the electrolyser stack system). This green hydrogen production facility needs up to 159 MWh of green electricity and 24,900 liters/h of water in order to produce up to 2,800 hg/h of hydrogen (99,95% of purity and 30 bar of pressure), up to 22,400 kg/h of oxygen (98,5% of purity and ambient pressure) and up to 52.5 MWh of thermal energy (temperatures between 60°C and 50°C).
- Low pressure hydrogen storage with 76.2 tonnes of capacity at 30 bar of pressure.

- Hydrogen compression system in order to compress the hydrogen from the low-pressure hydrogen storage up to the Fischer-Tropsch system. The hydrogen compression system will compress up to 2,800 kg/h of hydrogen from 10 up to 30 bar of pressure.
- Small size Fischer-Tropsch process consumes up to 2.8 tonnes/hour of hydrogen and up to 19.62 tonnes/hours of carbon dioxide, in order to produce up to 14.43 tonnes/h of green methanol. The carbon dioxide will be supplied for a steel factory directly to the Fischer-Tropsch process (the green methanol facility will be bought the carbon dioxide from the steel factory and the steel factory will be paid money to green methanol facility in order to reduce their carbon dioxide emissions). The green methanol production will be sent directly to a methanol storage and after to their main consumers like transport, energy carrier or chemical process.
- Green methanol storage with the capacity to storage up to 550 tonnes. This storage system will be used in order to supply green methanol to the mobility sector, energy carrier sector and chemical industry sector.

The main goal of the facility is to produce green methanol. However, it is possible use the oxygen as a by-product and also the heat as a by-product due the facility location (industrial area with a lot of industries around).

Each tonne of hydrogen produced via electrolyser with green electricity instead steam methane reforming reduce around 12,1 tonnes of CO₂. In this regard, this facility can reach reduction of the CO₂ emission rights that usually the methanol facilities need to buy in the market. This means that the facility receives revenues from CO₂ emissions reduction.

The main technic and economic considerations in order to analyse the price that is necessary put to the green methanol tonne to reach the 10% of the Internal Rate of Return (IRR) are the following:

- Study period: 20 years.
- Price of green electricity supplied with a Purchase Procurement Agreement (PPA): 37.5 €/MWh.
- Tap water cost: 2 € per cubic meter.
- Operation hours per year: 8,000.
- Alkaline electrolyser CAPEX: 600 €/kW.
- Alkaline electrolyser system OPEX (% investment cost per year): 1.5.
- Operation hours up to 10% of stack degradation: 80,000.
- Stack replacement cost (% of the total cost): 20%.
- Low pressure hydrogen storage at 30 bar CAPEX (€/kg): 245.
- Low pressure hydrogen storage system OPEX (% investment cost per year): 0.5.
- Hydrogen compression system from 10 to 30 bar CAPEX (€/kg/h): 2,112.8.
- Hydrogen compression system from 10 to 30 bar OPEX (% investment cost per year): 6.
- Carbon dioxide purchase price (€/tonne): 50.
- Carbon dioxide revenues from reduce the steel factory carbon dioxide (€/tonne): 30.
- Fischer-Tropsch system CAPEX (€/kW of electrolyser system): 800.

- Fischer-Tropsch system OPEX (% investment cost per year): 5%.
- Green methanol storage system CAPEX (€/tn): 550.
- Green methanol storage system OPEX (% investment cost per year): 0.5.
- Personal cost (€/year): 1,000,000.
- Land rental cost (€/year): 200,000.
- French loan duration: 10 years.
- Finance (% of the total investment): 70.
- Own resources (% of the total investment): 30.
- Financial interest (%): 5.
- Taxes (%): 25.
- Integration cost (piping, electricity, control, safety, etc.,) (% of the main equipment): 12.
- Depreciation (%): 95.
- Depreciation (years): 20.
- Discount rate (%): 7.5.
- Inflation (% per year): 1.5.
- Weighted Average Cost of Capital (WACC) (%): 9.11.
- Oxygen sales price (€/tonne): 30.
- Heat sales price (€/MWh): 15.
- CO₂ avoided emission rights (€/tonne): 28.5.

The main data from this specific business case, taking into account that the goal is fix the methanol price in a value that allow us have an Internal Rate or Return of 10% are the following (see picture 20):

- Total investment needed (€): 265,940,101.
- **Methanol sales price (€/tonne): 612.4.**
- Total cost per year (€). The total cost can be different in the years because the degradation of the electrolyser stack and the degradation of the Fischer-Tropsch reactor make that the hydrogen and methanol production change in the years. However, the total cost per year is between 77 and 67 million euros.
- Total revenues per year (€). In the same way that the total cost per year, the total revenues per year is between 103 and 93 million euros.
- CO₂ emission reduction per year (tonnes of CO₂): In the same way that the total cost per year, the CO₂ emission reduction per years is between 298,000 and 264,000.
- Net Present Value (NPV) (€): 8,031,868
- Pay-Back (PB) (years): 18.13.

In order to know how the business case can change when some parameters are changed, some sensitivity analysis will be performed. Two of the main parameters are the methanol sales price (€/tonne) and the

CO₂ emission right (€/tonne). The sensitivity analysis will consider for one hand ammonia sales price (€/tonne) from 450 up to 700, and for the other hand CO₂ emission right (€/tonne) from 10 up to 100. The parameter that will be observed in the sensitivity analysis is the Internal Rate of Return (IRR). IRR lower than 10% will be put in white colour and IRR higher than 10% will be put in green colour. All the combinations between ammonia sales price and CO₂ emissions right that obtain an IRR higher than 10% (green colour) will be desirable scenarios for the investors (figure 21).

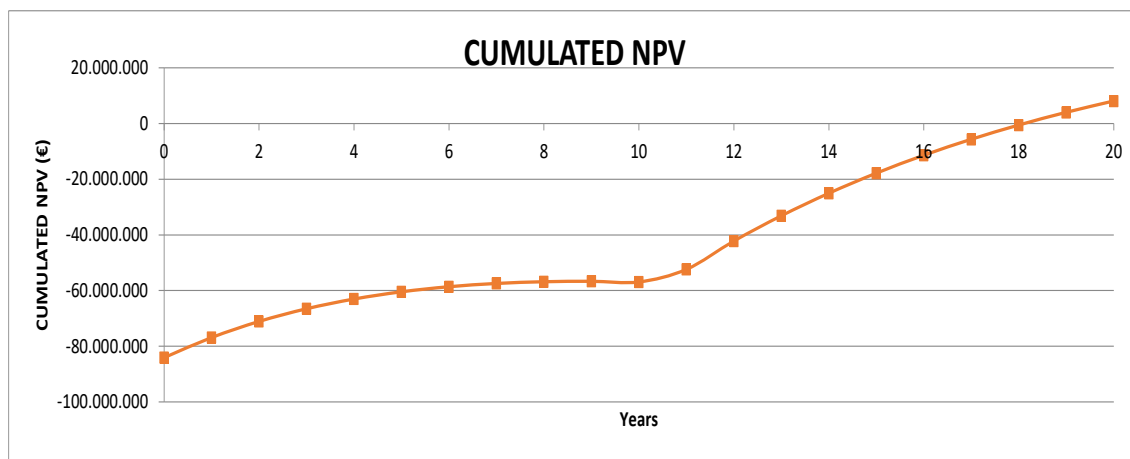

Figure 20: Cumulated Net Present Value VS years.

Methanol is currently produced from fossil fuels, mainly natural gas. China is the biggest methanol producer. This country uses primarily coal (around 64%). Methanol production costs mainly depend on feedstock and an electricity price. Natural gas-based methanol production costs range from 50 €/t to 400 €/t (see figure 22).

		METHANOL SALES PRICE (€/tonne)											
		450	475	500	525	550	575	600	625	650	675	700	725
CO ₂ PRICE (€/tonne)	10	-11,53%	-8,04%	-5,07%	-2,40%	0,10%	2,50%	4,84%	7,18%	9,53%	11,92%	14,36%	16,87%
	15	-9,84%	-6,63%	-3,82%	-1,23%	1,21%	3,58%	5,92%	8,26%	10,62%	13,03%	15,50%	18,05%
	20	-8,30%	-5,30%	-2,61%	-0,10%	2,31%	4,66%	6,99%	9,34%	11,72%	14,16%	16,66%	19,24%
	25	-6,87%	-4,03%	-1,44%	1,02%	3,39%	5,73%	8,07%	10,43%	12,84%	15,30%	17,84%	20,45%
	28,5	-5,92%	-3,18%	-0,63%	1,79%	4,15%	6,48%	8,82%	11,20%	13,62%	16,11%	18,67%	21,31%
	35	-4,25%	-1,64%	0,82%	3,20%	5,54%	7,88%	10,24%	12,64%	15,10%	17,63%	20,24%	22,93%
	40	-3,02%	-0,49%	1,92%	4,28%	6,62%	8,96%	11,34%	13,76%	16,26%	18,82%	21,46%	24,19%
	45	-1,84%	0,63%	3,01%	5,35%	7,69%	10,05%	12,45%	14,90%	17,43%	20,03%	22,71%	25,47%
	50	-0,69%	1,73%	4,09%	6,43%	8,77%	11,14%	13,57%	16,05%	18,61%	21,25%	23,97%	26,76%
	55	0,43%	2,82%	5,17%	7,50%	9,86%	12,25%	14,70%	17,22%	19,81%	22,49%	25,24%	28,08%
	60	1,54%	3,90%	6,24%	8,58%	10,95%	13,37%	15,85%	18,40%	21,03%	23,75%	26,54%	29,41%
	65	2,63%	4,98%	7,31%	9,67%	12,06%	14,50%	17,01%	19,60%	22,27%	25,02%	27,85%	30,75%
	70	3,71%	6,05%	8,39%	10,76%	13,17%	15,65%	18,19%	20,82%	23,52%	26,31%	29,17%	32,11%
	75	4,79%	7,13%	9,48%	11,86%	14,30%	16,81%	19,39%	22,05%	24,80%	27,62%	30,51%	33,48%
	80	5,86%	8,20%	10,57%	12,98%	15,45%	17,99%	20,61%	23,30%	26,08%	28,94%	31,87%	34,87%
	85	6,94%	9,29%	11,67%	14,10%	16,61%	19,18%	21,84%	24,57%	27,39%	30,28%	33,24%	36,26%
90	8,02%	10,38%	12,78%	15,25%	17,78%	20,39%	23,08%	25,86%	28,71%	31,63%	34,62%	37,67%	
95	9,10%	11,48%	13,91%	16,40%	18,97%	21,62%	24,35%	27,16%	30,04%	33,00%	36,02%	39,10%	
100	10,19%	12,59%	15,05%	17,57%	20,18%	22,86%	25,63%	28,48%	31,39%	34,38%	37,43%	40,53%	

Figure 21: Sensitivity analysis between green methanol sales price and CO₂ emission right price.

The share of feedstock in production costs varies from 39.6 to 85.7%. Coal-based methanol, as a rule, is more expensive. For example, in 2017 in China, its cost was 235 €/t.

Methanex Monthly Average Regional Posted Contract Price History				
Date	Methanex Non-Discounted Reference Price (MNDRP)		Methanex European Posted Contract Price (MEPCP)	Methanex Asian Posted Contract Price (APCP)
	\$/gal	\$/MT	€/MT	\$/MT
Nov-19	\$1.03	\$342	€ 280	\$295
Dec-19	\$1.03	\$342	€ 280	\$275
Jan-20	\$1.03	\$342	€ 275	\$275
Feb-20	\$1.19	\$396	€ 275	\$335
Mar-20	\$1.19	\$396	€ 275	\$310
Apr-20	\$1.08	\$359	€ 260	\$260
May-20	\$0.94	\$313	€ 260	\$225
Jun-20	\$0.87	\$289	€ 260	\$215
Jul-20	\$0.83	\$276	€ 235	\$215
Aug-20	\$0.83	\$276	€ 235	\$245
Sep-20	\$0.86	\$286	€ 235	\$260
Oct-20	\$1.01	\$336	€ 275	\$300
Nov-20				
Dec-20				

Figure 22: Methanol Methanex monthly average regional posted contract price history 2020.

China can produce biomethanol and renewable methanol from the following resources: biomass, municipal solid and water waste, carbon dioxide and renewable electricity. Biomass-based methanol cannot compete with fossil fuel-based methanol. Its production cost ranges from EUR500/t to EUR600/t.

The production costs of renewable methanol based on wind power and carbon dioxide depend on electricity cost and vary from 610 €/t to 1520 €/t, but are falling [23,24].

The green methanol cost obtained in the business case is 612.4 €/tonne. The obtained value is in between and in the low part for the value obtained in the references defined previously.

Conclusions

In this chapter five business cases related with green hydrogen, green ammonia and green methanol in different locations like Chile, China, Australia, Argentina and Austria was studied deeply.

The main conclusions for the five-business case developed in the chapter are the following:

The main conclusions for the five business cases developed in the chapter are the following:

- All the products (hydrogen, ammonia and methanol) obtained in the facilities defined in the business cases are more expensive than the products with fossil fuels origin. However, the extra cost will be covered mainly with the expected higher price related directly to the carbon dioxide emissions.
- All the business cases studied in the chapter, the pay-back value when we consider a 10% of Internal Rate Return are always around 18 years. This means that the business will work properly but with not so much improvised problems.
- The parameter that has more impact in the business cases defined in this chapter is the electricity price. Lower electricity prices imply a net present value increase and a pay-back reduction.
- One of the main parameters that can help to the business case viability is the carbon dioxide emission price. Higher values of carbon dioxide imply directly better results from the economical point of view.
- All the values obtained regarding the sales price in the different business cases (hydrogen, ammonia and methanol) are aligned with information obtained in different forecast reports. This means that the methodology used in all business cases is validated and can be a good tool for next business cases studies.

REFERENCES

- [1] P.-M. Heuser, D. S. Ryberg, T. Grube, M. Robinius, et D. Stolten, « Techno-economic analysis of a potential energy trading link between Patagonia and Japan based on CO₂ free hydrogen », Spec. Issue Sel. Contrib. Eur. Hydrog. Energy Conf. 2018 Málaga Spain March 14th - 16th, vol. 44, no 25, p. 12733-12747, mai 2019, doi: 10.1016/j.ijhydene.2018.12.156.
- [2] International Energy Agency (IEA), « World Energy Outlook ». 2019.
- [3] Bruce S et al., « National Hydrogen Roadmap, Pathways to an economically sustainable hydrogen industry in Australia ». CSIRO, 2018, [En ligne]. Disponible sur: <https://www.csiro.au/en/Do-business/Futures/Reports/Hydrogen-Roadmap>.
- [4] «Japan's Hydrogen Strategy and Its Economic and Geopolitical Implications». <https://www.ifri.org/en/publications/etudes-de-lifri/japans-hydrogen-strategy-and-its-economic-and-geopolitical-implications> (consulté le juill. 30, 2020).
- [5] «Japan's hydrogen future may be fuelled by Australian renewables », ARENA WIRE, juill. 27, 2018. <https://arena.gov.au/blog/hydrogen-future-australian-renewables/>.
- [6] IHS Chemical, Chemical Economics Handbook, Hydrogen. 2015.
- [7] IEA, « The Future of Hydrogen », p. 203, juin 2019.
- [8] Hydrogen Council, « Path to hydrogen competitiveness A cost perspective ». 2020, [En ligne]. Disponible sur: https://hydrogencouncil.com/wp-content/uploads/2020/01/Path-to-Hydrogen-Competitiveness_Full-Study-1.pdf.
- [9] Armijo, Julien & Philibert, Cédric. (2019). Flexible production of green hydrogen and ammonia from variable solar and wind energy. Case study of Chile and Argentina. 10.1016/j.ijhydene.2019.11.028.
- [10] Enaex. 2017 annual report. 2018.
- [11] PwC. Embracing clean hydrogen for Australia How the journey towards decarbonisation can be fuelled by Hydrogen. March 2020.
- [12] https://www.wepower.com/media/WhitePaper-WePower_v_2.pdf
- [13] Regierungsprogramm 2020-2024. Aus Verantwortung für Österreich.Vienna, 2020.- <https://www.bundeskanzleramt.gv.at/dam/jcr:7b9e6755-2115-440c-b2eccbf64a931aa8/RegProgramm-lang.pdf>
- [14] HansBöhm, AndreasZauner, Daniel C.Rosenfeld, RobertTichler. Projecting cost development for future large-scale power-to-gas implementations by scaling effects. <https://doi.org/10.1016/j.apenergy.2020.114780>.
- [15] Philipp-Matthias Heuser, D. Severin Ryberg, Thomas Grube, Martin Robinius, Detlef Stolten. Techno-economic analysis of a potential energy trading link between Patagonia and Japan based on CO₂ free hydrogen. International Journal of Hydrogen Energy. Volume 44, Issue 25, 2019. Pages 12733-12747, ISSN 0360-3199, <https://doi.org/10.1016/j.ijhydene.2018.12.156>.
- [16] International Energy Agency. Transport, Energy and CO₂: Moving Toward Sustainability; OECD/IEA: Paris, France, 2009. Available online: <https://www.iea.org/news/transport-energy-and-co2-moving-towardsustainability>.

- [17] IEA. Global Energy & CO₂ Status Report 2019. Available online: <https://www.iea.org/reports/global-energyco2-status-report-2019/emissions>.
- [18] Chan, T. Methanol Fuel Blending In China. In Proceedings of the Enmore 14th International Me OH Week, Nanjing, China, 9–10 July 2019. Available online: <https://www.methanol.org/wp-content/uploads/2019/07/Methanol-Fuel-Blending-in-China.pdf>.
- [19] Methanol Institute. Methanol Price and Supply/Demand. Available online: <https://www.methanol.org/methanol-price-supply-demand>.
- [20] Methanol Production in the United States from 1990 to 2018. Available online: <https://www.statista.com/statistics/974802/us-methanol-production-volume>
- [21] Methanol Production in Russia in 2018 Increased by 7%. Available online: <http://rcc.ru/article/proizvodstvometanola-v-rossii-v-2018-g-vyroslo-na-7--69007>.
- [22] Methanex Investor Presentation. March 2019. Available online: <https://www.methanex.com/sites/default/files/investor/MEOH-Presentation-2019--03-04.pdf>.
- [23] Roode-Gutzmer, Q.I.; Kaiser, D.; Bertau, M. Renewable Methanol Synthesis. *ChemBioEng Rev.* 2019, 6, 209–236.
- [24] Bozzano, G.; Manenti, F. Efficient methanol synthesis: Perspectives, technologies and optimization strategies. *Prog. Energy Combust. Sci.* 2016, 56, 71–105

GENERAL CONCLUSIONS AND RECOMMENDATIONS

Based on the results of the different Sub-Tasks and Task Forces presented in this report as well as the expertise of the Task38 members, a set of recommendations for easing the deployment of P2X systems is suggested hereafter. Techno-economic, regulatory and modelling related recommendations are addressed allowing to target a wide range of stakeholders: policy makers, industries and analysts (academic, research organisations, etc.). First, general recommendations (non-specific to one pathway) are suggested then, the different Power to X pathways are tackled.

Techno-economic recommendations

The value chain for low-carbon hydrogen is not completely developed at commercial scale today. Depending on the PtX pathway and on the step of the supply chain, different stages of maturity are faced with specific technical challenges. As stated in the IEA Innovation report [1], unlocking the steps of the supply chain with the lowest maturity levels is essential in order to allow the deployment of the full pathway.

To do so, further research, development and innovation (R&D&I) is required as well as further demonstration projects. This is not only the responsibility of research organizations or industries working on the specific related technologies, but also of governments and local authorities via the adequate R&D&I financing tools.

Overall, improvements are still needed in order to ensure a high global efficiency of the pathway [2]. The use of critical materials is also problematic and further research should be dedicated to this issue [3]. Enhancing the lifetime of certain technologies such as SOEC by improving the material stability is also one major research field to be supported. The Innovation IEA report details specific recommendations to foster innovation in PtX field (among other new technologies) [1].

For more developed pathways, the challenges are different. The latter are rather addressing the economic viability of the PtX systems, and the related technologies. Several technologies have reached the required maturity and the next step is to be deployed in the market. However, only relying on the market system

will not allow these technologies to enter market, since these technologies are today not competitive compared with historic solutions (generally fossil based) providing the same services.

The highlighted next step is upscaling these technologies. This will allow reducing the costs as a consequence of the economies of scale and the learning experience behind.

When the demand is existent, one way to do it is by building on existing industries, and infrastructure [4]. For instance, the IEA Hydrogen report highlights the importance of making industrial clusters the nerve centres for scaling up the use of clean hydrogen. This offers “the opportunity to create hubs that bring down the cost of low-carbon hydrogen pathways and kick-start new sources of demand”. In particular, the coastal industrial hubs, located near ports, can be attractive [4].

Beyond relying on the existing demand in industry to bring down the costs, benefiting from the existing infrastructure, when possible, can help prevent big expensive delivery infrastructure investments.

By relying on the existing industrial demand to scale up clean hydrogen technologies, and reduce the costs, the new demands can be fostered. However this does not mean to focus on the industrial pathway only.

The other pathways (HtF, HtG, HtQ) also need to be advanced in order to reach appropriate scale for competitive technologies.

One business case helping to improve the overall system cost is targeting different markets for the produced hydrogen as part of the sector coupling potential. This will help enhance the profitability of the electrolyzers by increasing its utilisation rate, while helping to unlock new markets with lower hydrogen production costs.

Next to the economics of hydrogen systems, there is also the environmental impact. The interest in hydrogen is led by the environmental concern and the target to lower the global GHG emissions. For a specific service, the interest in substituting fossil based technologies by hydrogen based ones is conditioned by the carbon footprint of the hydrogen production. Low carbon hydrogen production may not match big hydrogen demand hubs, geographically speaking. Hence, a need for international trading of hydrogen is foreseen. It will allow linking the regions with low carbon hydrogen production potential with regions where the demand is voluntarist but under low carbon production resource constraints.

Hence kick-starting international hydrogen trade for ultimate global low-carbon market – (Asia Pacific, Middle East, North Africa, Europe) will be one of the next major steps to be taken [4].

Pathway specific

PtH

The electrolyzers that are the foundation of PtX pathways are already available in the markets, however, still need further cost reductions in order to be “market-ready”.

Lowering the costs to trigger the demand will depend on two major components. First the capital cost of the technology and second the operation costs driven by the electricity prices and the utilization rates.

On the first point, lowering the technology cost depends on the scaling up of manufacturing capacities and on its ability to bring down the costs [5]. PEMEC still has to be improved in its cost and efficiency compared to AEC. The latter being the most mature technology on markets today. Regarding SOEC electrolyzers, they are still in the development phase, but there are a number of pilot projects under way [6].

Regarding the second point, there would be obvious benefits from making productive use of curtailed renewable allowing to benefit from cheap electricity [4]. However, it is not possible to base the business case only on surplus electricity, since this will lead to low utilization rates of the electrolyzers. Ensuring an acceptable utilization rate is crucial in order to reach competitive costs. This can present an issue in regions relying on renewable hydrogen and where renewable resources are scarce. Hence, international hydrogen trade is expected to grow in size and importance.

Furthermore, benefitting from the electrolyzers flexibility can present an economic interest, since it allows an extra-profit coming from the services provided to the electricity system (reserve market participation, frequency control remuneration, etc.). However, this participation can be considered as a double-edged sword, since the more numerous the participants to the flexibility market, the lower the remuneration for the service provision, which is somehow a “cannibalisation” effect [7].

HtP

Further work on the system overall efficiency is needed to ensure the techno-economic viability of this pathway. There is a potential for competitiveness of producing electricity from hydrogen but only when considering peak hours, where electricity prices are already high. H2P can however be a serious alternative in a future where fossil based electricity generation means (for peak hours) are “forbidden” [8].

HtG-H2

The injection of hydrogen in the gas infrastructure can help boost low carbon hydrogen supply while making one of the most reliable sources of demand. According to the IEA, even 5% blending (volume based) would create large new global hydrogen demand. A total shift to 100% hydrogen can also be foreseen (projects are already in place, like Leeds in the UK [9]). This will enable deep emissions reduction for the long term [4].

Various studies [10]–[12] suggest that a transition of the gas pipeline system to hydrogen is viable, but that only practice will show the technical and economic viability. Hence, further demonstration and pilot projects are still needed in order to assess materials as well as end-use adequacy to the transition towards hydrogen in the gas grid.

It is critical that learnings from the existing and planned demo projects in the years to come addressing these issues are shared to help unlock the challenges of this pathway [2]. Industrial transparency will be key in the years to come to help accelerate learnings for a shared benefit.

Centralizing this kind of information can be the objective of a dedicated international initiative.

HtG-M

The HtG-Methanation pathway has the advantage of requiring much less conditions with regards to the adequacy of the infrastructure. However, the final cost of the process leads to higher costs than the direct injection of H₂. Hence specific support mechanisms are needed to trigger this market. These will be discussed in the Policy recommendations part.

The availability of source and storage of carbon is also a major point to address when considering this pathway. This can even condition the viability of this pathway.

HtF-H₂

Hydrogen use for mobility via fuel cells might be the most “popular” energy related application. However, specific attention should be given to supporting the transport options where hydrogen has most to offer [4]. Long distance transport means are an attractive market for hydrogen that can be shortly competitive once the required scales are reached [13].

The availability of the refueling infrastructure is also key. In order to avoid the chicken egg dilemma, some suggest vertical integration of the whole pathway, meaning that, one stakeholder, can master both vehicle and refueling facility manufacturing. In this way, the deployment of both can be synchronized.

Another option is to adopt a strategy where refueling infrastructure is dedicated to a specific fleet of vehicles, like captive fleets. This will help start with “affordable” investments. Then, these vehicle fleets have the advantage of predictable driving and refueling patterns which will help maximize the utilization rates of the refueling infrastructure [14].

HtF-S

E-fuels have the advantage of requiring less component modifications compared to fuel cells. They may hence benefit from the existing appliances but also from the existing refueling infrastructure [6].

E-fuels also allow decarbonizing sectors that have limited or lacking alternative options (like aviation, shipping, etc.). However, the costs are high today.

The availability and cost of the CO₂ feedstock input is key factor affecting the final costs. “Whether a producer of CO₂ would be willing to sell it to a synthetic fuel manufacturer at close to the cost of capture would depend on the prevailing CO₂ emissions price or the level of any competing financial benefit for sending the CO₂ to long term geological storage, if available” [5]. Hence, carbon pricing will play a major role in the years to come, to define the viability of this pathway.

Furthermore, with high targets to phase out fossil-based energy, carbon sources might decrease considerably. Accordingly, it is critical to start studying the technical and economic viability of sustainable sources of CO₂ such as biomass combustion processes or direct air capture of CO₂ [2]. The same conclusions and recommendations are valid for the HTF-G and HtMe pathways.

HtI

The hydrogen existing industrial applications are a major opportunity for the development of Power to Hydrogen technologies and for bringing down the relative costs. Indeed, these markets (refineries, etc.) are already established and present high shares of hydrogen today’s use. There is hence scope to build on hydrogen’s current uses by scaling up low-carbon production and fostering innovation [4].

As for the iron industry, more process development is needed to test its techno-economic viability, but the global climate benefits could be very substantial [2].

HtA

In industry, ammonia production based on green hydrogen is technically viable today [2]. Switching to electrolysis requires political support in order to ensure competitive costs. This market is key in driving the scaling up potential and bringing down the costs.

HtQ

Benefitting from existing gas infrastructure can play a major role in defining the competitiveness of hydrogen to heat when considering a residential level [8].

Political recommendations

While for most of the applications of hydrogen, market penetration is conditioned by the ability to scale up production to bring down the costs, this scale up is conditioned by the existence of the adequate political framework.

To do so, different actions can be taken by the policy makers in order to ease the deployment of PtX pathways [15]. The policy measures can be divided as follows:

National strategies

Governments play an important role in setting national targets. Establishing these targets and/or long-term policy signals is crucial to foster investor confidence, confidence that is hampered by uncertainty and risk. This can be done via dedicated roadmaps to hydrogen deployment, as multiple examples across the globe: Japan, France, Australia, Korea, etc. These roadmaps provide strong objectives for critical stakeholders to converge around.

This can also be addressed through more global measures; like setting ambitious GHG reduction or renewable deployment targets, which will help foster low carbon technologies. The public measures are also reinforced by ambitious private pledges. The latter initiatives can be supported by public authorities via Innovation funds or by solving specific regulatory barriers.

Regulation

Governments have a major role to play in removing regulatory and legal barriers that hampering investments in hydrogen today – for instance, by facilitating the process to obtain permits to install a specific facility (electrolysers, fuelling stations, etc.).

Standardisation

Mass manufacturing of hydrogen related equipment like electrolysers, fuel cells and components of refuelling stations will drastically contribute to reduce the costs. This is only feasible on a global scale if international standards are agreed [4]. Hence, a standardization effort is crucial in order to ease the cost drops allowed by the scale effect. Governments can play a role in supporting industries to coordinate national and international initiatives around standards (for example, regarding pressure levels, hydrogen injection rates in NG grids, safety, etc.). National standardization institutions and international bodies such as the International Organization for Standardization (ISO) have a key role to play in such a process. On the governmental side, regulatory bodies need to be on board to actually implement standards.

Incentives

Governments can also foster the development of hydrogen technologies through adequate incentives such as tax breaks, subsidies or penalties on fossil-based alternatives to encourage (or even mandate) the initial market steps of hydrogen [13]. For instance, implementing a carbon price is required to both increase the profitability of low-carbon hydrogen production (compared to benchmark processes such as steam methane reforming), and the profitability of hydrogen use as a substitute to fossil-fuel options (for transport, gas use, etc.)

For the technologies that are still in need for further research and studies, governments can also play a role by promoting R&D and knowledge sharing.

Coordination

As neutral stakeholders, governments are well positioned to coordinate private efforts around potential local investment opportunities. Having the global view on a national basis, governments can not only coordinate but also set priorities and directions to organize the strategic investment efforts (demonstration projects and knowledge sharing) in the most optimized way, easing the first steps of deployment.

Pathway specific policy recommendations

Power to H₂

Upstream, low-carbon hydrogen production requires low-carbon electricity. Energy policies should promote renewable energy penetration, or more generally low-carbon electricity. This is a win-win strategy since hydrogen production can serve as a measure to avoid curtailment of excess electricity, to adjust the power demand by providing grid balancing services, or even to allow more renewable electricity to enter new applications in the form of a green gas, green chemical and green fuel. Hydrogen business cases can become more profitable when hydrogen systems are allowed to participate in grid balancing or ancillary services and capacity mechanisms. Hence, acknowledging the PtX flexibility potential and regulating it is required.

Further incentives can consider exempting electrolysis from paying electricity taxes for example, or subsidizing part of the electrolyser cost.

Penalizing the fossil-based competitor is also crucial to trigger the market. At present, there is a lack of regulations or penalties being applied to conventional polluting methods of hydrogen production to make them more expensive and ease the transition to low-carbon hydrogen. Carbon pricing can be one of the important mechanisms to consider.

H2 to X

Downstream, hydrogen system deployment can be fostered by sector-specific measures, via implementing standards and/or incentives during the transition.

H2 to P

The hydrogen to power pathway is still expensive today. It may have sense when considering peak hours as previously explained (techno-economic recommendations). However, in order to reach competitiveness, penalizing fossil peak electricity generation means is essential [8]. In a world where fossil fuel means are forbidden, hydrogen may be the only way to produce electricity during peak hours and hence contribute to the stability of the electricity system during “stress” hours.

H2 to G

The injection into natural gas networks will need government support in order to promote its market penetration. Acknowledging the actual greenhouse gas mitigation for gas applications by also accounting the contribution of methane leakages during processing and transport of natural gas (and implement the relevant incentives/penalties accordingly); a clear target for the hydrogen blending concentration into the gas grid could be set. This concentration currently varies a lot from one region to another. It can reach 10% (of the volume) like in Germany for example, while it does not exceed 6% in France and 0.1% in the UK. A harmonization of the standards at the European level (but not only) is crucial to prepare a more suitable market penetration environment. Standards for natural gas pipeline systems, underground storage and use of gas mixtures in burners have generally been designed from the viewpoint of a few percent hydrogen in natural gas. In the years to come, if hydrogen gas becomes the norm, these standards need to be revised.

A system of Guarantees of Origin can be set for biogas and hydrogen as an appropriate measure to stimulate the use of renewable gases.

Additionally, to foster the development of “green” gas, feed-in tariffs may be implemented in the transition. Such schemes exist for bio-methane injection [15]. Hydrogen or synthetic methane could be made eligible for similar support.

A quota system can also be discussed, to foster the H2 to gas applications.

H2 to Fuel

HtF-H2

Regarding the mobility market segment, moving to the decarbonisation of the transport sector may go through the coexistence of the different technologies in order to be able to meet the GHG emissions reduction targets. Setting a pledge for the carbon emission reductions related to the transport sector is important but not sufficient since it does not clarify the prospects for each low-carbon mobility option. It is leading to the misconception of considering that these options will only compete against each other, while they can complement each other in order to achieve the targets. A clear strategic roadmap leading to the realization of the pledged targets is required. Incentives could also include, in the transition, grants to reduce the vehicle price paid by the consumer. It is then important to think beyond the sole light passenger duty vehicles (i.e. by including trucks, trains, maritime use), and incentivize the infrastructure development jointly with the vehicle purchase. Other financial support mechanisms include carbon pricing and carbon related taxation for vehicles, which allows penalizing the fossil-based alternatives and help hydrogen vehicles reach competitiveness. A system of tax and/or fees exemptions (example: registration fees and highway tolls) can also be taken into account to promote clean technologies, including hydrogen).

HtF-S and HtF-G

The economy of E-fuels being partly based on the carbon price, setting a clear framework of carbon pricing can be one of the major political responsibilities to foster this market. Besides, setting quotas for fuel shares (for instance in aviation, shipping, other) can help boost the use of these synthesized fuels and initiate economies of scale.

H2 to I

The existing industrial markets: refineries together with HtA and HtMe are expected to continue to drive the hydrogen demand worldwide. However stronger environmental constraints (regarding the sulphur content or the carbon footprint of these industry activities) can play a major role in enhancing the hydrogen demand. As a matter of fact, according to [16], refineries will have to invest in larger capacities for hydrogen production in order to cope with the new environmental measures in the maritime sector. Promoting the use of low-carbon hydrogen in industry by implementing adequate certificates, subsidies and/or penalties; ensure a "level playing field" for products obtained with low-carbon hydrogen, which can foster the transition to low carbon hydrogen production via the development of electrolysis. Low carbon Hydrogen could help to revamp or update potential "stranded" assets, like gas turbine, by replacing fossil fuels (eg natural gas) by hydrogen for example.

HtQ

Overall, to unleash the hydrogen potential, governmental support is needed. Private industrial initiatives cannot, alone, foster its development. Governmental and regional support can take different forms. It can

be financial like granting subsidies, feed-in tariffs or premiums (which is already the case for the injection of biogas into the grid, and in some countries for EV). Or it can be setting standards or targets such as the concentration of hydrogen into the NG grid, or the modalities of a potential hydrogen participation to the electricity reserve market. Thus, relevant policies require a holistic approach, by proposing adequate measures for the industry and energy sectors (gas and power) adapted to the regional contexts.

Modelling related recommendations

Methods for producing energy scenario results are diverse, and not always clearly presented. Most major energy scenarios are based on an energy system model. In this section, based on ST4 work [17], best practice recommendations are suggested to ensure an adequate modelling of PtX systems and a fair representation of the different pathways in the renowned scenarios.

1) Scenarios must use appropriate modelling tools

- Models must capture sufficient temporal detail: amongst the different hydrogen potential contributions to the energy system, its ability to provide flexibility to the electric system can be a game changer in improving the electrolysis process profitability [18]. However, in order to capture this potential, an important factor that should be taken into account is the temporal resolution of the considered models. Furthermore, the high temporal resolution allows to accurately assess the hydrogen cost through the adequate estimation of the load factor that can be improved via the flexibility provision (participation to the reserve markets for instance). Multi-year models are attractive when addressing investment decision dynamics over a relatively long period of time. It is generally difficult to do both (refined temporal resolution and multi-year decision making, due to high computing requirements).

- Models must capture sufficient spatial detail: Likewise, the geographical scope can vary from analysing single projects or systems to modelling the energy system of the whole world. For instance, the geographic information system (GIS)-based models allow reaching very high spatial resolution through the possibility of mapping large sets of data. More details are available in [19].

The spatial resolution can be of major importance when considering the infrastructure deployment issue. In turn, the infrastructure representation impacts the cost, the energy consumption and the emissions of a given energy vector. Beyond the transmission and distribution selected pathway (pipeline or trucks), the delivery cost highly depends on the travelled distance and the geography of the travelled pathway. Furthermore, a refined geographic resolution can provide useful insights regarding the relevance of the system design and the location strategies of the different facilities, for instance, highlighting the trade-off between a centralized and a decentralized design [20].

- Models must appropriately represent technologies and inter-sectoral connectivity: The bottom-up process is a technology-rich approach based on thorough descriptions of technologic aspects of the energy system and how it can develop in the future. Hydrogen emergence in such models is hence dependent on the refined description of the current and prospective hydrogen technologies and the associated techno-economic assumptions. Representing the competitors on the different markets, it allows determining the required technology improvements (technical improvements and cost targets) in order to reach market

penetration. Implementing proper learning curves in the models is also required to capture accurately the deployment potential.

Beyond the technological representation, the sectoral representation is crucial in order to highlight the multi sectorial decarbonization potential as well as the sector coupling potential of Power to X systems.

- Models must represent the complexity of consumer behaviour: Another perspective for further research is modelling and capturing the consumer behaviour. This is important for modelling the new mobility services and behaviours, including the aspects that drive the user preferences, since capturing these aspects like the preference of drivers towards the vehicle recharging time and autonomy could lead to different results regarding hydrogen penetration in the mobility sector. In order to capture the consumer behavioural aspects that drive the energy demand, agent-based modelling (ABM) can be considered [21].

- Scenarios and models must also consider other objectives than minimizing the cost. Considering external costs: impact on environment, health expenses, etc. can be a game changer when setting an interest hierarchy in different technologies.

2) Scenarios must use consistent and substantiated data assumptions

Data is a very important part of the modelling experience. Adequate and consistent data is crucial in order to ensure an level playing field and do not penalize technologies over others, especially in a bottom up modelling framework, where competitiveness between technologies in the different sectors is dependent on input data regarding current but also prospective costs and efficiencies of the different technologies.

All these requirements while remaining manageable and user-friendly and preserving the transparency of the methodologies can be difficult to ensure.

To sum up, all modelling approaches present assets and limitations. No model is perfectly complete. No model suits all research questions. In order to overcome the limits, one option can be to complement the models with one another: linking between different kinds of modelling tools improves the representation of the energy system. Several examples can be found in the literature [22]–[25].

REFERENCES

- [1] IEA, « Energy Technology Perspectives, Special Report on Clean Energy Innovation ». 2020, [En ligne]. Disponible sur: https://webstore.iea.org/download/direct/4022?fileName=Energy_Technology_Perspectives_2020_-_Special_Report_on_Clean_Energy_Innovation.pdf.
- [2] IRENA, « Hydrogen: A Renewable Energy Perspective ». 2019, [En ligne]. Disponible sur: https://www.irena.org/-/media/Files/IRENA/Agency/Publication/2019/Sep/IRENA_Hydrogen_2019.pdf.
- [3] Joint Research Centre, « Critical Raw Materials for Strategic Technologies and Sectors in the EU, A Foresight Study ». European Commission, 2020, Consulté le: sept. 10, 2020. [En ligne]. Disponible sur: <https://ec.europa.eu/docsroom/documents/42881>.
- [4] IEA, « The Future of Hydrogen », p. 203, juin 2019.
- [5] International Energy Agency (IEA), « Energy Technology Perspectives (ETP) ». 2020, [En ligne]. Disponible sur: <https://www.iea.org/reports/energy-technology-perspectives-2020>.
- [6] World Energy Council et Frontier Economics, « International Aspects of Power-to-X Roadmap, A report prepared for the World Energy Council Germany ». 2018, [En ligne]. Disponible sur: <https://www.frontier-economics.com/media/2642/frontier-int-ptx-roadmap-stc-12-10-18-final-report.pdf>.
- [7] O. Tlili, C. Mansilla, D. Frimat, et Y. Perez, « Hydrogen market penetration feasibility assessment: Mobility and natural gas markets in the US, Europe, China and Japan », *Int. J. Hydrog. Energy*, vol. 44, n° 31, p. 16048-16068, juin 2019, doi: 10.1016/j.ijhydene.2019.04.226.
- [8] DNV-GL, « Hydrogen in the Electricity Value Chain ». 2019, [En ligne]. Disponible sur: <https://www.dnvgl.com/publications/hydrogen-in-the-electricity-value-chain-141099>.
- [9] PCAN, « Northern Gas H21 Leeds City Gate », *Leeds Climate Commission*. <https://www.leedsclimate.org.uk/hydrogen-gas> (consulté le mai 22, 2020).
- [10] C. J. Quarton et S. Samsatli, « Power-to-gas for injection into the gas grid: What can we learn from real-life projects, economic assessments and systems modelling? », *Renew. Sustain. Energy Rev.*, vol. 98, p. 302-316, 2018, doi: <https://doi.org/10.1016/j.rser.2018.09.007>.
- [11] DNV-GL, « Verkenning waterstofinfrastructuur ». 2017, [En ligne]. Disponible sur: https://www.topsectorenergie.nl/sites/default/files/uploads/TKI%20Gas/publicaties/DNVGL%20rapport%20erkenning%20waterstofinfrastructuur_rev2.pdf.
- [12] E.ON, « Hydrogen levels in German gas distribution system to be raised to 20 percent for the first time », *E.ON*, 2019. <https://www.eon.com/en/about-us/media/press-release/2019/hydrogen-levels-in-german-gas-distribution-system-to-be-raised-to-20-percent-for-the-first-time.html>.
- [13] Hydrogen Council, « Path to hydrogen competitiveness A cost perspective ». 2020, [En ligne]. Disponible sur: https://hydrogencouncil.com/wp-content/uploads/2020/01/Path-to-Hydrogen-Competitiveness_Full-Study-1.pdf.
- [14] Mobilité Hydrogène France, « H2 Mobilité France, Study for a Fuel Cell Electric Vehicle national deployment plan ». 2019, [En ligne]. Disponible sur: <https://www.fch.europa.eu/sites/default/files/Smart%20Spec%20Fabio%20Ferrari%20%28ID%202436338%29%20%28ID%202497336%29.pdf>.
- [15] F. Dolci *et al.*, « Incentives and legal barriers for power-to-hydrogen pathways: An international snapshot », *Int. J. Hydrog. Energy*, vol. 44, n° 23, p. 11394-11401, mai 2019, doi: 10.1016/j.ijhydene.2019.03.045.

- [16] International Maritime Organization, « Third IMO Greenhouse Gas Study ». 2014.
- [17] C. J. Quarton *et al.*, « The curious case of the conflicting roles of hydrogen in global energy scenarios », *Sustain. Energy Fuels*, vol. 4, n° 1, p. 80-95, 2020, doi: 10.1039/C9SE00833K.
- [18] Tractebel et Hincio, « Study on early Business Cases for hydrogen in energy storage and more broadly power to H2 applications, Final report ». FCHJU, juin 2017, [En ligne]. Disponible sur: https://www.fch.europa.eu/sites/default/files/P2H_Full_Study_FCHJU.pdf.
- [19] « What is GIS? », *esri*. <https://www.esri.com/en-us/what-is-gis/overview> (consulté le mai 27, 2019).
- [20] Olfa Tlili, « Hydrogen systems : what contribution to the energy system? Findings from multiple modelling approaches ». 2019, [En ligne]. Disponible sur: <https://tel.archives-ouvertes.fr/tel-02414562/document>.
- [21] V. Rai et A. D. Henry, « Agent-based modelling of consumer energy choices », *Nat. Clim. Change*, vol. 6, p. 556, mai 2016.
- [22] N. Strachan, N. Balta-Ozkan, D. Joffe, K. McGeevor, et N. Hughes, « Soft-linking energy systems and GIS models to investigate spatial hydrogen infrastructure development in a low-carbon UK energy system », *Int. J. Hydrog. Energy*, vol. 34, n° 2, p. 642-657, janv. 2009, doi: 10.1016/j.ijhydene.2008.10.083.
- [23] J. P. Deane, A. Chiodi, M. Gargiulo, et B. P. Ó Gallachóir, « Soft-linking of a power systems model to an energy systems model », *8th World Energy Syst. Conf. WESC 2010*, vol. 42, n° 1, p. 303-312, juin 2012, doi: 10.1016/j.energy.2012.03.052.
- [24] A. Krook-Riekkola, C. Berg, E. O. Ahlgren, et P. Söderholm, « Challenges in top-down and bottom-up soft-linking: Lessons from linking a Swedish energy system model with a CGE model », *Energy*, vol. 141, p. 803-817, déc. 2017, doi: 10.1016/j.energy.2017.09.107.
- [25] F. Riva, F. Gardumi, A. Tognollo, et E. Colombo, « Soft-linking energy demand and optimisation models for local long-term electricity planning: An application to rural India », *Energy*, vol. 166, p. 32-46, janv. 2019, doi: 10.1016/j.energy.2018.10.067.

MAJOR TASK ACCOMPLISHMENTS

During these incredible four years of work, different accomplishments of the Task38 can be highlighted. Below is a list:

- Round table organization and participation at WHEC 2018: "The Role of Hydrogen in the Energy Policies"

As part of the 22nd edition of the World Hydrogen Energy Conference (WHEC 2018), a round table co-organized by the IEA's Hydrogen TCP Task 38 and the Hydrogen Council and moderated by Paul Lucchese (Capenergies, France) brought together researchers and industry stakeholders to talk about the role of hydrogen in energy scenarios with an orientation towards modeling and data aspects.

This roundtable was preceded by an assessment of the role of hydrogen in reference energy scenarios and a presentation of IEA Hydrogen TCP by Paul Lucchese. It was followed by a presentation of the Hydrogen Council and the H2 Scaling-Up roadmap made by Guillaume de Smet (Air Liquide, France) who highlighted the potential of hydrogen in its various applications on the horizon of 2050 with the assessment of the resulting investment needs.

The role of hydrogen in the scenarios of the International Energy Agency was also discussed. These scenarios are particularly important because they are consulted by "decision / policy makers" and can influence investment decisions.

According to Martin Robinius (Jülich Forschungszentrum, Germany), the presence of a hydrogen "module" in energy models is not sufficient to prove the full potential of this vector. The spatial and temporal granularity of the models is very important and can decide the presence or absence of hydrogen in the results.

This point was supported by Sheila Samsatli (University of Bath, UK), who highlighted the fact that taking into account inter-seasonal storage and the need for flexibility of the system in general makes hydrogen appear more noticeable in the results, and without the required fineness of the temporal and geographical resolution, hydrogen risks being completely absent in the results and the scenarios.



Figure 42: WHEC2018 Roundtable – Rio de Janeiro, Brazil

- [Workshop on demonstrations \(ST2\) in Aix-en-Provence](#)

An international workshop on the analysis of Power-to-X demonstration projects was organized on November 20, 2018 in Aix-en-Provence, hosted at the National School of Arts and Crafts (Arts et Métiers) by Capenergies and sponsored by GRTgaz. This international workshop brought together nearly 90 participants from 18 countries, with the remarkable interventions of Hychico (an Argentinian demonstration project carried out by an industry without public subsidies), the AIE, and the Fuel Cell and Hydrogen Joint Undertaking (FCH JU). French demonstrators were also represented by the presentations of GRTgaz (Jupiter1000 project), Engie (GRHYD project) and Storengy (Méthycentre project). Discussions took place during the round tables as part of the workshop as well as the in-depth analysis sessions. In the framework of ST2, a database of more than 190 projects was established, it will feed the design of a roadmap for Power-to-X demonstration projects. This roadmap is now under development and is expected to be available online by end 2020.



Figure 43: Power-to-X demonstration projects workshop – Aix en Provence, France

- [Workshop on hydrogen in energy models in Bath \(ST4\)](#)

In the framework of ST4 of the Task 38, a workshop on the theme “Energy system models and the role of hydrogen” was organized at the University of Bath on May 17th, 2017. Bringing together 40 participants, this workshop aimed to provide a forum for discussions on energy system models (objectives, specificities) and the potential role played (or not) by hydrogen in these models.

The presentations reported on various models, macroscopic or very detailed on the spatio-temporal level, developed by the University of Bath (United Kingdom), the Forschungszentrum Jülich (Germany), Unitec Institute of Technology (New Zealand), and the Institute of Applied Energy (Japan).

The conclusion shared during this workshop is the need for fine models to deal with hydrogen in a relevant way in all its dimensions as an energy carrier. The question of data was also raised as a key point, especially for exchanges with reputable models.

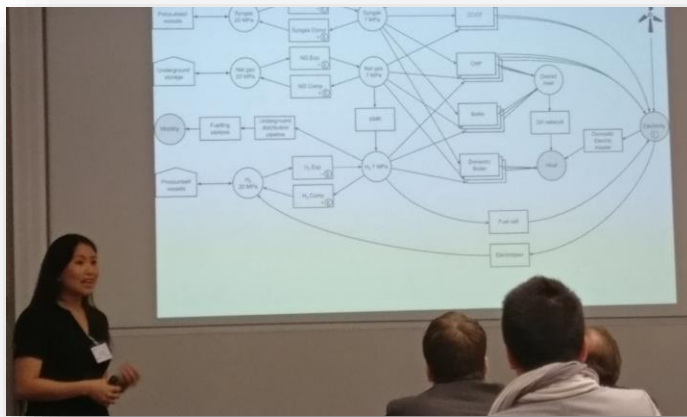

Figure 44: Workshop on “Energy system models and the role of hydrogen”, Bath University, UK

- Workshop on Hydrogen in the Mediterranean region (ST5) in Puertollano

In the framework of ST5 of the Task38, a workshop dedicated to the potential of a Mediterranean hydrogen hub was held on September 26, 2019 in Puertollano (Spain), hosted by the National Hydrogen Center (CNH2), and co-organized by CNH2, Task 38 and Capenergies. In front of around forty participants, the speakers shared insights addressing the many hydrogen projects, particularly in connection with maritime applications (from Spain, Italy, South of France, etc.). The workshop concluded with a round table setting out the first steps towards more collaborations on the subject.



Figure 45: Workshop on the potential of a Mediterranean hydrogen hub, Puertollano, CNH2

- Communication:

Papers

Five papers have been published in international journals, mainly in the International Journal of Hydrogen Energy, and one paper is still under review. A wide range of topics has been addressed: regulatory framework, demonstration projects, power to X systems modelling, electrolyser costs, etc. A list is available below:

- Z. Chehade, C. Mansilla, P. Lucchese, S. Hilliard, J. Proost. 2019, IJHE, *Review and analysis of demonstration projects on power-to-X pathways in the world*: <https://www.sciencedirect.com/science/article/pii/S0360319919333142>
- C. J. Quarton, O. Tlili, L. Welder, C. Mansilla, H. Blanco, H. Heinrichs, J. Leaver, N. J. Samsatli, P. Lucchese, M. Robinius and S. Samsatli. 2019, Sustainable Energy&Fuels, *The curious case of the conflicting roles of hydrogen in global energy scenarios*: <https://pubs.rsc.org/en/content/articlelanding/2020/se/c9se00833k#!divAbstract>
- Dolci, D. Thomas, S. Hilliard, C. Fúnez Guerra, R. Hancke, H. Ito, M. Jegoux, G. Kreeft, J. Leaver, M. Newborough, J. Proost, M. Robinius, E. Weidner, C. Mansilla, P. Lucchese. 2019, IJHE, *Incentives and legal barriers for power-to-hydrogen pathways: An international*

snapshot: <https://www.sciencedirect.com/science/article/pii/S0360319919309693>

- J. Proost, 2019, IJHE, State-of-the art CAPEX data for water electrolyzers, and their impact on renewable hydrogen price settings: <https://www.sciencedirect.com/science/article/pii/S0360319918324157>
- J. Proost, 2020, IJHE, Critical assessment of the production scale required for fossil parity of green electrolytic hydrogen: <https://doi.org/10.1016/j.ijhydene.2020.04.259>

Participation to conferences (WHEC, P2G, EEM, IAEE)

Task 38 members have also participated to different conferences, not only hydrogen specific.

- P. Lucchese, A. Le Duigou, C. Mansilla, Power-to-Hydrogen and Hydrogen-to-X: System Analysis of the techno-economic, legal and regulatory conditions: A new task of the IEA Hydrogen Implementing Agreement, 21st World Hydrogen Energy Conference (WHEC 2016), Zaragoza, Spain, June 13-16, 2016. Oral Communication.
- R. Dickinson, F. Dolci, A. Le Duigou, P. Lucchese, N. Lymperopoulos, P. Mancarella, C. Mansilla, S. Samsatli, N.J. Samsatli, D. Thomas, M. Weeda, E. Weidner, O. Tlili, Power-to-Hydrogen and Hydrogen-to-X pathways: Opportunities for next energy generation systems, 14th International Conference on the European Energy Market (EEM15), Dresden, Germany, June 6-9, 2017. Oral Communication.
- M. Robinius, L. Welder, S. Ryberg, C. Mansilla, M. Balan, F. Dolci, R. Dickinson, R. Gammon, P. Lucchese, N.D. Meeks, A. Pereira, S. Samsatli, J. Simon, O. Tlili, S. Valentin, E. Weidner, Power-to-Hydrogen and Hydrogen-to-X: Which markets? Which economic potential? Answers from the literature, 14th International Conference on the European Energy Market (EEM15), Dresden, Germany, June 6-9, 2017. Oral Communication.
- J. Proost, State-of-the-art CAPEX data for water electrolyzers, and their impact on renewable hydrogen price settings, European Fuel Cell conference & exhibition (EFC17), Naples, Italy, December 12-15, 2017.
- P. Lucchese, C. Mansilla, F. Dolci, R. R. Dickinson, C. Funez, L. Grand-Clément, S. Hilliard, J. Proost, M. Robinius, M. Salomon, and S. Samsatli, Power-to-Hydrogen and Hydrogen-to-X: latest results

of Task 38 of the IEA Hydrogen Implementing Agreement, European Fuel Cell conference & exhibition (EFC17), Naples, Italy, December 12-15, 2017.

- M. Robinius, J. Linssen, C. Mansilla, M. Balan, F. Dolci, R. Dickinson, C. Funez, L. Grand-Clément, S. Hilliard, H. Iskov, J. Leaver, A. Pereira, J. Proost, C. Quarton, S. Samsatli, O. Tlili, S. Valentin, E. Weidener, P. Lucchese, Techno-economic Potentials and Market Trends for Power-to-Hydrogen and Hydrogen-to-X based on a Collaborative and International Review, 22nd World Hydrogen Energy Conference (WHEC 2018), Rio De Janeiro, Brazil, June 17-22, 2018. Oral Communication.

Technology briefs

Three technology briefs have been published on the IEA Hydrogen TCP website. A list is suggested below. A fourth brief will soon be available to address the participation of hydrogen to the electricity security market.

- S. Hilliard, R. Dickinson, P. Mancarella, C. Mansilla, 2017?, What services to the grid? What hydrogen can do?
 - J. Proost, S. Saba, M. Müller, M. Robinius, D. Stolten, 2018, Electrolysis: What are the investment costs? State of the art and outlook.
 - Dolci, D. Thomas, S. Hilliard, C. Fúnez Guerra, R. Hancke, H. Ito, M. Jegoux, G. Kreeft, J. Leaver, M. Newborough, J. Proost, M. Robinius, E. Weidner, C. Mansilla, P. Lucchese, 2019, Power-to-Hydrogen / Hydrogen-to-X: What are the incentives and legal barriers? Current status in Belgium, France, Germany, Italy, Japan, New Zealand, Norway, Spain, The Netherlands, and the UK.
-
- [Award for the Operating Agent: Christine Mansilla](#)

Following the 6th plenary meeting of the Task38 on September 25th, 2019, Christine Mansilla, received a trophy from the IEA for her outstanding work as an operating agent from 2016 till 2019. Her serious work, perseverance and exceptional human qualities made her a remarkable and unique Task operating agent.



Figure 46: Christine Mansilla receiving the "Outstanding Operating Agent" Award from the IEA

FORWARD LOOKING

After closing the Task38, further collaborations and events are also foreseen in order to ensure a continuity of the work, so that it wouldn't be a "one shot" work effort. A list of the envisaged perspectives is presented below. The list is not comprehensive, and many future tasks will use the results of Task 38.

Furthermore, joined webinar and event will be organized in 2021 to discuss on the key results of Task 38, with some collaboration with Power to X organization.

An IEA Hydrogen TCP Power to X road map will be published in 2021 as a final output of Task 38.

Establishment of a joined IEA Secretariat/Hydrogen TCP Database on projects deployment

Based on the feedback of the database created in Task38/ST2 on PtoX demo projects, a reference database will be established in 2021 through a collaboration between IEA Secretariat Paris and Hydrogen TCP. This database will include information on all hydrogen production deployment projects. This database will be very useful for data modelling, statistic, tracking progress on hydrogen deployment and many IEA tools.

Collaboration with Task41

A new Task within the Hydrogen TCP is defined, called Task41. This new Task will address the hydrogen data and modelling issues in details, addressing the representation of hydrogen in different sets and types of energy system models, including TIMES based models. Different members of Task38 are participating to Task41, some of them are even leading sub-tasks within the new Task. This will allow ensuring the continuity of some of the work done in the framework of Task38 as well as sharing lessons and documents from our work.



Figure: Task41 definition meeting, Brussels, September 2019

Plenary session at the IAEE 2021 conference

A plenary session under the “Government Track” type is organized by Task38 and will take place in July 6th, 2021. Invited speakers are

- Paul Lucchese from the Hydrogen TCP
- Guillaume de Smet from The Hydrogen Council
- And Martin Robinius from IEK-3, Jülich Forschungszentrum

The session will tackle Power to X system from different standpoints: political, industrial and academic. In this occasion, this report as well as the ST2 roadmap will be presented.



Final plenary meeting

The final plenary meeting of Task38 is to be organized in the next months in order to close the Task activities. A physical face to face meeting is preferred. Hence, seeing the Covid situation, no date for the meeting has been set yet. More information will be available as soon as th situation gets clearer.

APPENDICES

i ENTSE-E SO GL article 153(2b.i)