

Final report

1.1 Project details

Project title	English: ELITE – Enhanced Lightning Effects Testing Capabilities for Optimized Wind Turbine Reliability Danish: ELITE – Forbedrede tests til lynbeskyttelse af vindmøller
Project identification (program abbrev. and file)	ELITE – 64014-0172
Name of the programme which has funded the project	Energiteknologisk Udviklings- og Demonstrations Program (EUDP)
Project managing company/institution (name and address)	Global Lightning Protection Services A/S HI Park 445 7400 Herning Denmark
Project partners	Global Lightning Protection Services A/S (GLPS) Danmarks Tekniske Universitet (DTU)
CVR (central business register)	31480469
Date for submission	2018-07-06
Author	Stephan Vogel and Søren Find Madsen

1.2 Short description of project objective and results

1.2.1 English version

The ELITE project aimed at 1) investigating the lightning environment affecting large wind turbines, and 2) develop and construct test equipment capable of applying realistic lightning environments to large structures like wind turbine blades and nacelles. The research has greatly influenced the perception of lightning environment within the industry, by dissemination on conferences and active participation in standardisation committee meetings. The test equipment developed have been demonstrated on a full-scale test of a 67m wind turbine blade and documented the expected strength of realistic lightning testing on full size structures. The ambition of using the ELITE project as catalyst for worldwide expansion of the GLPS test activities, have worked as planned, and we are actively pursuing these options in 2017/2018.

1.2.2 Danish version

ELITE projektets formål har været at 1) undersøge det lyntekniske miljø omkring store vindmøller, og 2) at udvikle og konstruere fremtidens testudstyr til at teste hele vindmøllevinger og naceller med realistiske lynstrømme. Forskningen har styrket industriens og den akademiske verdens opfattelse af hvorledes lyn påvirker vindmøller (og hvordan vindmøller påvirker lyn), dels ved talrige publikationer i tidsskrifter og på international konferencer, og dels ved aktiv deltagelse i standardiseringsarbejde. Det udviklede test udstyr har været demonstreret

ved en fuldskala tests på en 67m vinge, og viste styrken ved test af hele strukturer. Ambitionen om at benytte ELITE projektet som springbræt til GLPS' videre ekspansion inden for tests over hele verden og også indfriet, og vi forfølger for tiden flere muligheder for at etablere tilsvarende test faciliteter i Kina.

1.3 Executive summary

This report compiles the work done in the context of the ELITE project. Starting in August 2014 and finalising by a demonstration test in October 2017, the work carried out have been divided into different work packages.

The main goal of the project is to design and implement a new generation high current generator that allows to perform realistic lightning current tests on full-scale components of the wind power industry: complete wind turbine blades and nacelles. The large size of these components limits the high current tests, due to the large impedances of the test samples. The large resistance and inductance of a full-scale blade will limit the current waveforms injected in terms of amplitude and energy. Taking into consideration the actual trend of larger wind turbines with bigger blades, this issue is even more limiting.

1.4 Project objectives

The overall goal of the ELITE project is to develop a new full-scale lightning test system for application to full size wind components like blades and nacelles. The new system developed is suitable to test the current and upcoming generation of larger wind turbine components for the offshore market, such as 5-10 MW nacelles and related blades with length of 60-100 m.

The specific project objectives included:

- Systematic collection and analysis of data concerning lightning protection of wind turbines generated during the past ten years on universities, in the manufacturing industry, on the customer side and from the numerous research projects completed by lightning consultants
- Design, construction and validation of an impulse current generator to comply with the lightning test requirements raised by the wind turbine industry and defined by the lightning environment identified. To accommodate the requirements to the test pulses set forward in terms of waveforms, amplitudes, energies, etc., this process will require several engineering disciplines. Apart from High Voltage engineering and research into new means of storing and releasing the extremely large quantities of energy, the mechanical design must also ensure safe and reliable operation. The complex system requires a thorough understanding of all processes and involved techniques, and here the research team at DTU along with the experienced engineers at GLPS will work closely together. The generator design and construction will, upon completion, enable wind turbine and blade manufacturers to get the necessary verification tests performed also for future even larger structures.
- Demonstration of the newly developed test system on large full test setup, nacelle, complete wind turbine blade, etc.
- The achieved experiences from testing large-scale systems with high level lightning impacts will lead to new approaches for defining test and verification requirements, and thereby assisting manufacturers in increasing the reliability of wind turbines. By pushing state of the art testing to a higher level, including requirements for certification and industrial standards, the entire industry will be driven in a cost-effective direction making wind power even more competitive.
- Increasing the testing capabilities in GLPS will further strengthen the position of not only GLPS, but also of Denmark as a leading country in providing sub-supplier services to the global wind industry.

The project was structured in five work packages (WP) which are listed in Figure 1 - Structure of the ELITE project. WP1 is dedicated to project management, dissemination and exploitation of project results – in order to ensure smooth progress of the technical activities

throughout the different phases of the project, as well as coordination of market oriented and knowledge communication actions. The development activities are organized in three sequential work-packages – focused on requirements and specifications (WP2), design work (WP3), and assembling and testing (WP4) of the new lightning test system. Finally, WP5 is dedicated to the activities related to the demonstration of new lightning test system under relevant conditions, i.e. performing lightning tests of large wind turbine components (full-length blade and/or a large nacelle).

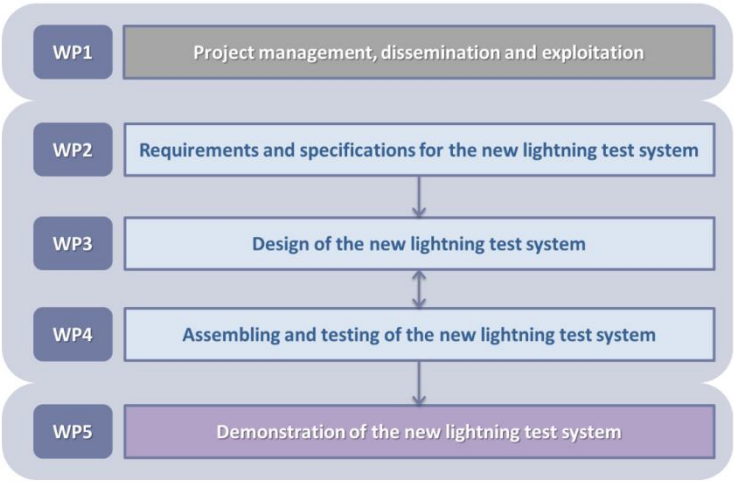

Figure 1 - Structure of the ELITE project

The timeline for the ELITE project is illustrated in Figure 2. The project was extended once due to delays in the delivery of components. Furthermore, an extension enabled to match the deadline of the ELITE project with the deadline of the related Ph.D. project.

Project title: ELITE – Enhanced Lightning effect TESting capabilities for optimized wind turbine reliability																																									
Project start: 01-08-2014																																									
Project Month	1	2	3	4	5	6	7	8	9	10	11	12	13	14	15	16	17	18	19	20	21	22	23	24	25	26	27	28	29	30	31	32	33	34	35	36	37	38	39		
År	2014					2015												2016												2017											
WP1	8	9	10	11	12	1	2	3	4	5	6	7	8	9	10	11	12	1	2	3	4	5	6	7	8	9	10	11	12	1	2	3	4	5	6	7	8	9	10		
WP2																																									
WP3																																									
WP4																																									
WP5																																									

Figure 2 - Timeline for the ELITE project (This table was revised several times)

1.5 Project results and dissemination of results

High current testing in the laboratory is an essential tool to help understanding the origin of physical damage caused by lightning flashes to wind turbine components. In this section, a short overview is provided which shows the most important achievements of this project.

1.5.1 Lightning Research – Work package 2

In the context of the ELITE project, a deep lightning research activity has been carried out to characterize the most salient lightning properties to be replicated by the new high current generator in WP2. Thanks to the research activity developed in ELITE, important results have been obtained in the context of lightning exposure risk assessment, correlation between meteorological data and winter lightning characteristics and the effect of wind in the development of the corona in exposed structures such as wind turbine blades under thunderstorm conditions. The specific activities in WP2 was:

- Analysis of lightning characteristics, the identification of lightning physical parameters and waveforms that need to be considered in the project. The source of this information is based on recent publications and a literature review. Furthermore, a

wide lightning data analysis from wind turbines is included, where the source of this data involves companies in the global wind power industry.

- Lightning exposure risk assessment of sub components on individual turbines as well as on entire wind farms. The development of a lightning exposure risk assessment methodology comprises both lightning exposure assessment based on statistical data and the calculations that can be derived from the standards, and an extended methodology that includes an in-depth study of entire wind plants considering the geographical features of the terrain.
- Multiphysics models of corona development at the tip of grounded structures and the effect of the wind in the corona development. This is particularly important to explain the attachment process observed for wind turbine blades, where the development of corona under thunderstorm conditions considering the different types of ion drift and diffusion equations, are found very important.
- Finally, the correlation between weather characteristics and winter lightning incidence focuses on studying the meteorological parameters that affect the appearance of winter lightning phenomena. Data from radiosondes all over the world and weather radar from localized areas have been used and correlated with lightning detection data to define a methodology to better foresee areas around the globe being particularly prone to winter lightning.

In the end of this work package, also the requirements for the following work package was defined. For instance, the current waveforms for the impulse generator were stated which need to be generated in order to produce a realistic lightning test impulse. Basically, there are two different current waveforms that need to be generated which are, Figure 3, the lightning current waveform of a first-return stroke with possible continuous currents and subsequent return strokes and, Figure 4, an upward lightning discharge with an initial continuous current and a subsequent return stroke.

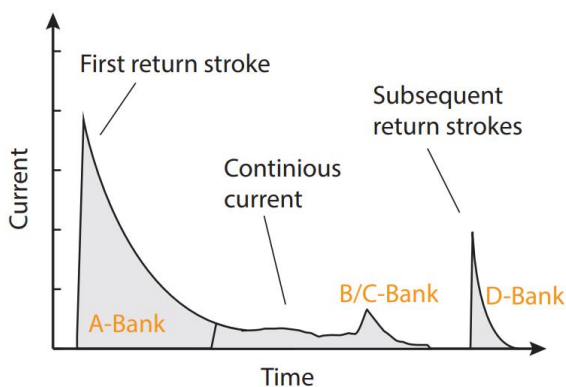

Figure 3 - A typical first return-stroke current composed out of first return stroke, continuous current and subsequent return stroke

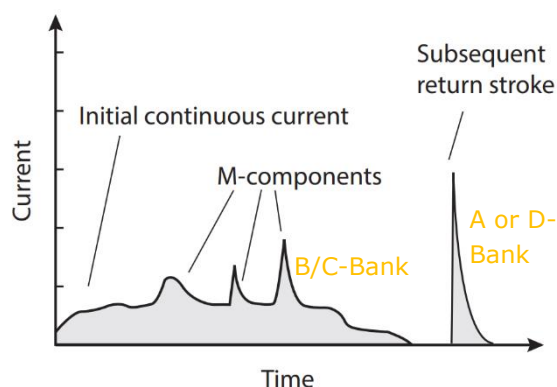

Figure 4 - A typical upward lightning current composed out of an initial continuous current and subsequent return strokes

Each of these lightning current component waveforms are characterized by individual properties, for example current steepness, maximum current and duration. Therefore, it was decided to create three different types of impulse generators each responsible for creating a unique current impulse which are:

- A-bank – responsible for the first return stroke
- B/C-bank – responsible for the continuous current
- D-bank – responsible for the subsequent return stroke

An overview over the properties of each components is listed in Table 1.

Table 1 - Physical properties of the different impulse types

	Waveform	Peak Amplitude [kA]	Charge [C]	Rise - Time [us]	Decay Time [us]	Multiplicity
First return stroke		Positive polarity 10 - 20 0	5-100	10	350	1
Continuous Current		0.4-1.2	0-1500	Duration: 100 - 2500 [ms]		1
Subsequent return stroke		1-20	0.2-4	0.2- 4.5	100	1...1 0

1.5.2 Design of a novel high current generator for full-scale wind turbine testing – Work Package 3

Work package 3 focused on the design of the generator. The design was made respecting the latest trends in the wind power industry and the limitations this implies. Larger samples make it a very challenging task to efficiently perform lightning verification tests but given that blades and nacelles becomes even more complex as they grow in size – the need for verification tests is ever increasing.

The developed generator consists in of three parts (A, B/C and D bank), with a common control system embracing all functions:

- General design aspects: division into different banks, modular approach, control and operation, test setup.
- A-bank design.
- B/C-bank design.
- D-bank.
- Control system.
- Test setup.

- Safety measures

One of the important inputs to the test generator is the impedance of the test sample. Wind turbine blades are characterized by the highest expected for the test generator due to their long and slender structure. In this respect the series resistance and the self-inductance of the overall blade design must be assessed. Table 2 presents the inductance and resistance values calculated for different protection configurations. The values have been obtained per unit length and correspond to the central section of a 50 m blade. The protection configurations under evaluation combine down conductors of different section and materials and carbon fiber elements (girders). No return path has been built around the protection configuration for lowering the impedance.

Table 2 - Resistance and inductance of wind turbine blades per meter section

Impedance per unit length	Single DC	Dual DC	Four DC	Single DC – two CFC girders	Dual DC – two CFC girders	Four DC – two CFC girders	Two CFC girders as DC	Four CFC girders as DC
35mm 2 Cu DC	Not applicable	L=1.35μH R=0.24 mΩ	L=1.02μH R=0.12 mΩ	L=1.4μH R=0.37 mΩ	L=1.15μH R=0.21 mΩ	L=0.96μH R=0.11 mΩ	L=0.9μH R=1.59 mΩ	L=0.9μH R=0.73 mΩ
50mm 2 Cu DC	L=1.74μH R=0.34 mΩ	L=1.33μH R=0.17 mΩ	L=1μH R=0.1m Ω	L=1.45μH R=0.28 mΩ	L=1.16μH R=0.15 mΩ	L=0.97μH R=0.08 mΩ	L=0.9μH R=1.59 mΩ	L=0.9μH R=0.73 mΩ
70mm 2 AL DC	L=1.71μH R=0.62 mΩ	L=1.31μH R=0.31 mΩ	L=1μH R=0.15 mΩ	L=1.3μH R=0.44 mΩ	L=1.1μH R=0.26 mΩ	L=0.96μH R=0.14 mΩ	L=0.9μH R=1.59 mΩ	L=0.9μH R=0.73 mΩ

The final results of the circuit design of the three impulse generators (A, B/C and D bank) is illustrated in Figure 5 - Figure 7. Each of these generators is designed to be operated individually or a sequential test operation can be programmed which creates a current waveform as depicted in Figure 3 or Figure 4. Testing of a current waveform individually allows the correlate the individual flash type to distinct failure modes whereas a combined flash exposes the device under test to the interaction between different electromagnetic, thermal and mechanical forces.

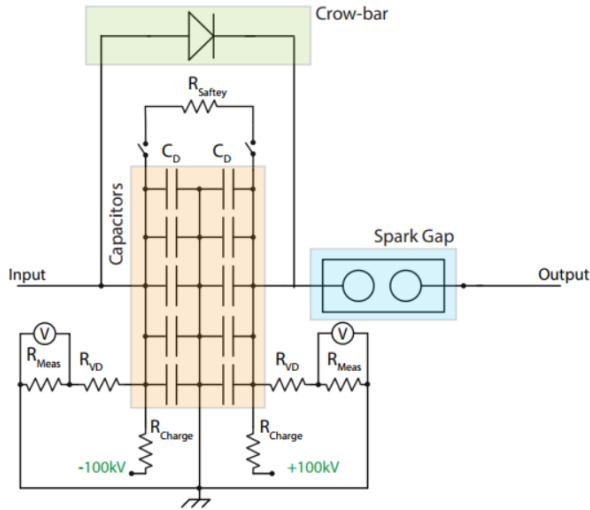

Figure 5 – Circuit design of the A-bank module with components explained.

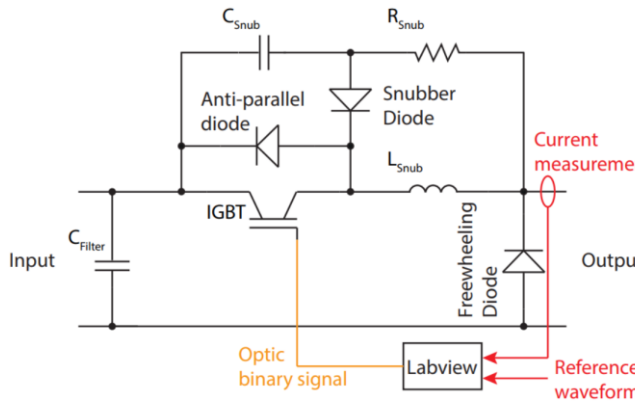

Figure 7 – Circuit design of the B/C-bank module with components indicated

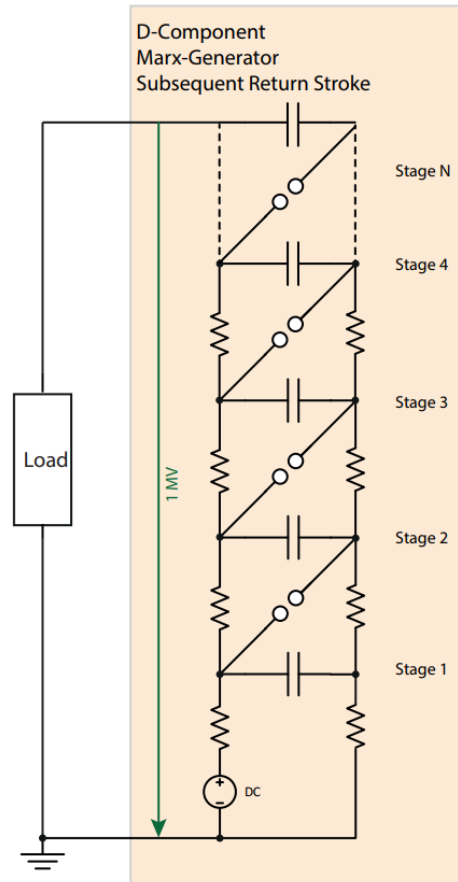

Figure 6 – Circuit design of the D-bank module

The circuit of the A-bank presented in Figure 5, shows the circuit elements of one A-bank unit. However, the A-bank is composed out of 12 of these high current generators which can be adapted to the electrical load of a test sample. For instance, several A-bank modules can be connected in a series/parallel connection in order to achieve a higher current output as depicted in Figure 8.

ELITE - Generator Overview

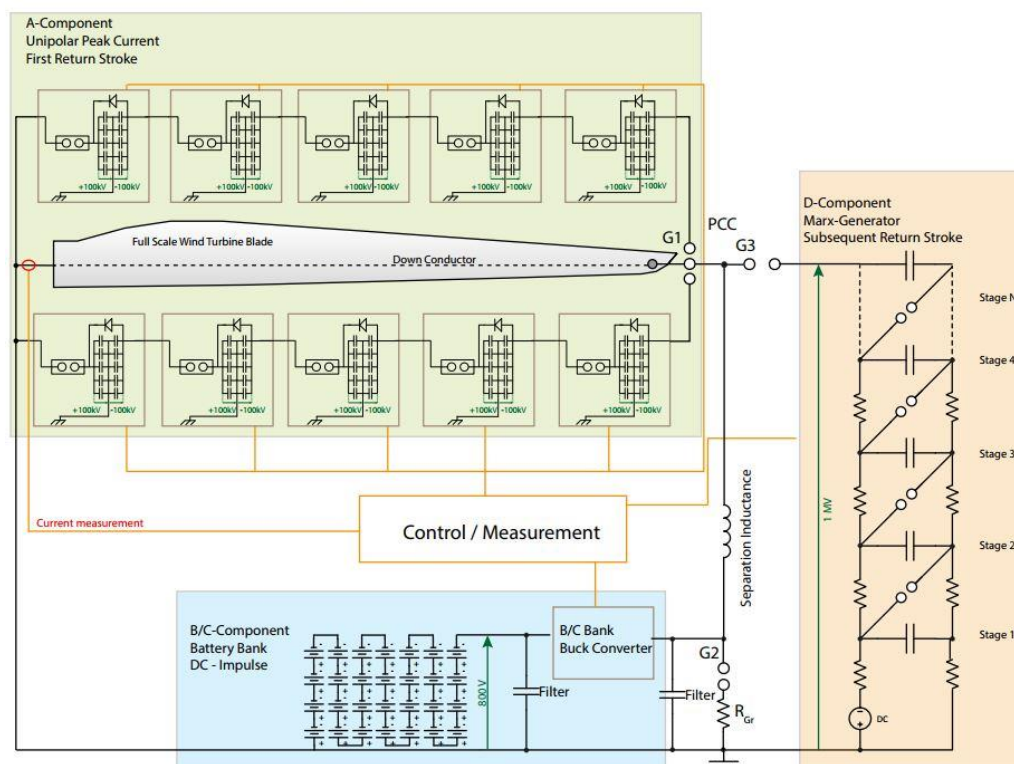

Figure 8 - The A, B/C - and D-bank interconnected for testing realistic lightning flashes

1.5.3 Assembly of the new high current generator – Work Package 4

Work package 4 defines the steps necessary in order to transform the conceptual work package 3 into physical components. The A and B/C – bank was assembled and tested in cooperation with the Technical University of Denmark and the Danish mechanical engineering company CUVA whereas the D – bank was design by GLPS but constructed by the Indian high voltage supplier Zeonics.

Figure 9 shows the sketch of one of the final A-bank modules with all relevant modules explained. Each module consists out of five physical high voltage capacitors. Each capacitor is has two terminals (bushings) that are rated for 100kV, leading to two separate capacitors inside one housing with an individual capacitance of 1.5 μ F. The capacitor bushings are connected in series connection. Therefore, one physical capacitor unit has a capacitance of 0.75 μ F. Five capacitors are connected in parallel, resulting in a total capacitance of 3.75 μ F per module.

Figure 10 shows a photograph of the physical B/C – bank with all relevant electrical components. The B/C-bank is responsible for creating the continuous current component in a lightning flash. The duration of this current component can extend to a duration of $t = 1.5s$ and a current amplitude of $I_p = 2kA$. Extremely high charge levels of up to 3000C can be created within one test. Unlike the A-bank, the electrical source of the B/C-bank is realized by a battery bank of 35 series connected 24V car batteries with a total resulting driving voltage of approximately 800V.

The D-bank, depicted in Figure 11, is able to create a faster current impulse compared to the A-bank which attempts to represent the current properties of a subsequent stroke. The generator is a typical Marx-type high voltage impulse generator with 10 capacitor stages of each $C_S = 100nF$ at a charging voltage of $U_0 = 100kV$ per stage. The capacitors are charged in parallel and discharged in series, leading to a total resulting capacitance of $C_g = 10nF$ at a voltage of up to $U_g = 1000kV$. The maximum output current is $I_p = 20kA$. The capacitor

bank is equipped with an encapsulated spark gap chamber including spark gap switches. Similar to the A-bank, the pressure in the discharge chamber can be regulated and hence the flashover voltage adjusted.

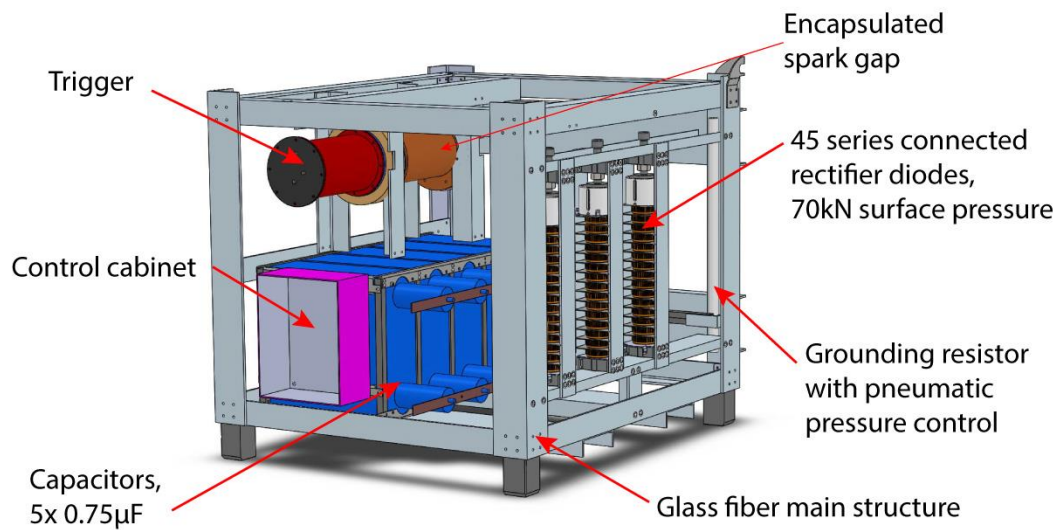

Figure 9 - Illustration of the A-bank module with components explained.

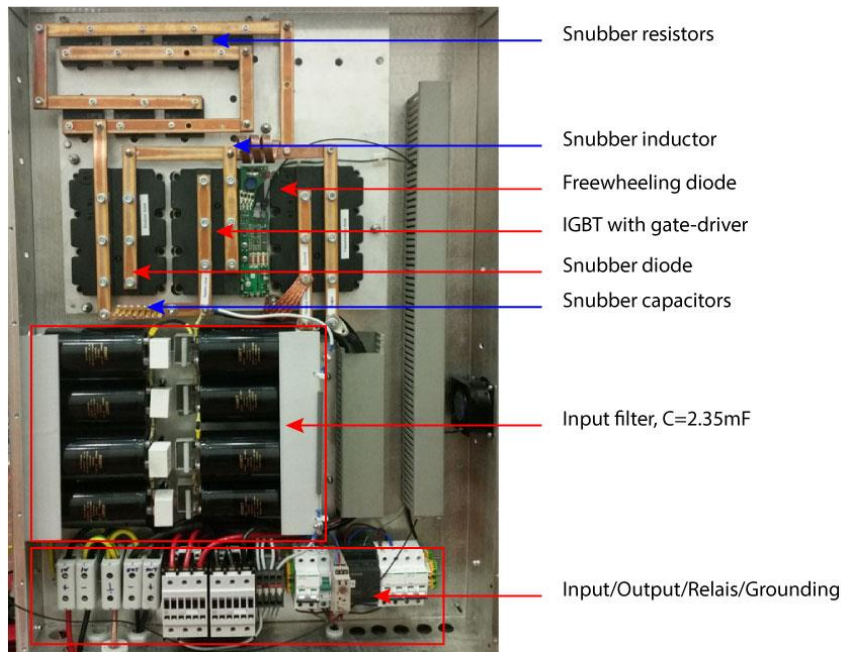

Figure 10 - Photograph of the B/C-bank module with components indicated



Figure 11 - Photograph of the D-bank module

The backbone of the ELITE test generator is the control system which is based on an Ethercat network topology. It is a real time high-speed Ethernet network from the automation hardware provider Beckhoff. It offers a flexible, modular, and synchronized network interface which is able to send and receive data to partner devices. Fiber optic connection between the modules ensures galvanic isolation to the control cabinet. An overview of the control system is provided in Figure 12. As can be seen, it contains the control and measurement system with one interface. The reference module provides the time frame between the receiving operational units for accurate operation with a microsecond resolution.

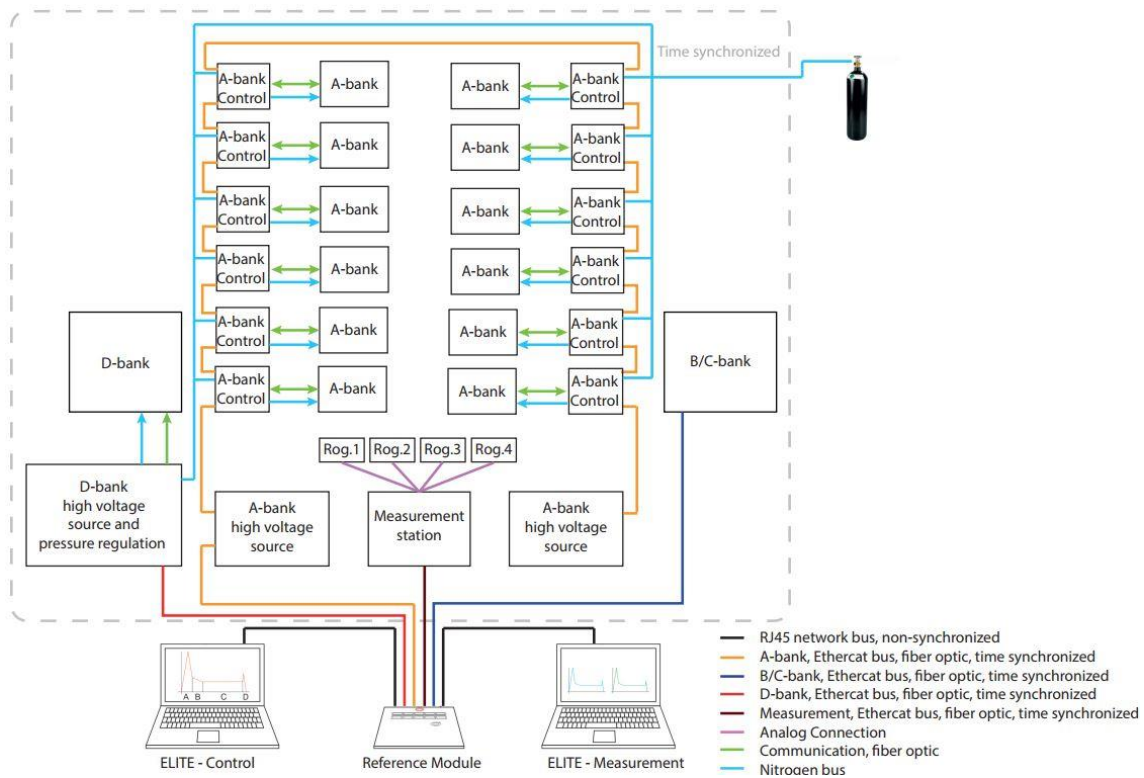

Figure 12 - Advanced control setup for interconnected operation

1.5.4 Full Scale Demonstration Test (9th of October 2017) – Work Package 5

At the 9th of October 2017, a full-scale demonstration test of the A-bank was performed at the mechanical wind turbine blade test center Blaest in Aalborg, Denmark. Blaest typically performs mechanical blade test such as parameter analysis, static proof tests, or fatigue tests; however, a perspective cooperation between GLPS and Blaest may also introduce lightning verification tests to the portfolio in the future. The advantage of performing multiple wind turbine tests within one laboratory is the reduced transportation effort of wind turbine components to various test facilities which is especially expensive for large structures.

The demonstration test was used to show the functionality of the ELITE concept to the project funding representatives of EUDP as well as interested participants from the Danish and international wind turbine industry (Goldwind, Senvion, Siemens Gamesa, Vestas, ...). The test was performed with ten A-bank modules which were connected in two parallel strings to a 67meter wind turbine blade with each five series connected modules. A photograph of the test setup is shown in Figure 13 and Figure 14. The resulting capacitance of the generator was $C_G = 1.5\mu\text{F}$. The modules were aligned closer to the tip of the blade, rather than fully distributed along the length of the blade. The reason for this configuration was the limited space around the root of the blade.

As a result of the demonstration test, the 41 participants from industry showed active interest in future full-scale high current testing activities. Furthermore, the importance of testing wind turbine components regarding lightning influence has once more been communicated which will lead to an improvement in quality in the wind turbine industry.

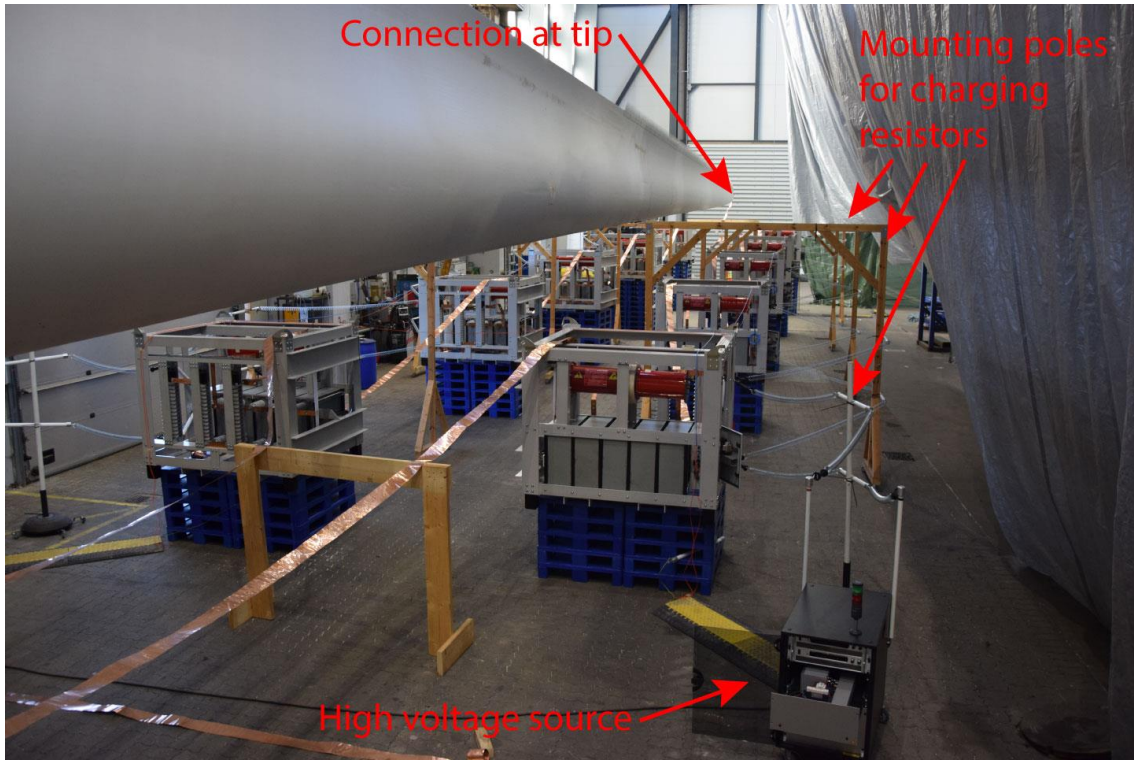

Figure 13 – A-bank connected to wind turbine blade at the demonstration.



Figure 14 – Photograph from the tip towards the root with the connected ELITE generator (A-bank)

1.5.5 Overview of publications from ELITE

From of the Ph.D. project, several international conference and journal papers were published.

Journal Papers:

- S. Vogel and J. Holbøll, "Experimental evaluation of discharge characteristics in inhomogeneous fields under air flow," *IEEE Trans. Dielectr. Electr. Insul.*, Accepted

- S. Vogel, M. Ishii, M. Saito, and D. Natsuno, "Upward lightning attachment analysis on wind turbines and correlated current parameters," *IEEEJ Spec. issue Winter Light.*, Accepted

Conference Papers

- K. Bertelsen, J. Lopez, S. Vogel, S. F. Madsen, and H. I. Park, "Enhanced lightning effects testing for optimized wind turbine reliability," in *EWEA OFFSHORE*, Copenhagen, Denmark, 2015.
- S. F. Madsen, S. Vogel, J. Lopez, A. C. Garolera, and K. Bertelsen, "Enhanced Lightning Effects Testing Capabilities," in *International Conference on Lightning and Static Electricity (ICOLSE)*, Toulouse, France, 2015.
- A. C. Garolera, S. Vogel, J. Lopez, S. F. Madsen, and K. Bertelsen, "Effect of Local Topography on Lightning Exposure of Wind Turbines," in *International Conference on Lightning and Static Electricity (ICOLSE)*, Toulouse, France, 2015.
- S. Vogel, J. Lopez, J. Holbøll, S. F. Madsen, A. C. Garolera, and K. Bertelsen, "Numerical Simulation of the effect of wind removing the corona space charge over grounded structures under thunderstorm conditions," in *International Conference on Lightning and Static Electricity (ICOLSE)*, Toulouse, France, 2015.
- S. Vogel, J. Holbøll, J. López, A. C. Garolera, and S. F. Madsen, "Lightning Attachment Estimation to Wind Turbines by Utilizing Lightning Location Systems," in *International Lightning Detection Conference (ILDC)*, San Diego, United States, 2016.
- S. Vogel, J. Lopez, A. C. Garolera, and S. F. Madsen, "Lightning Location System Data from Wind Power Plants Compared to Meteorological Conditions of Warm- and Cold Thunderstorm Events," in *International Colloquium on Lightning and Power Systems (ICLPS)*, Bologna, Italy, 2016.
- S. Vogel, J. Holbøll, J. López, A. C. Garolera, and S. Find, "European cold season lightning map for wind turbines based on radio soundings," in *International conference on lightning protection (ICLP)*, Estoril, Portugal, 2016.
- S. Vogel, M. Ishii, M. Saito, E. Power, D. Natsuno, and T. Co, "Upward lightning attachment analysis on wind turbines and correlated current parameters," in *International Symposium on Winter Lightning (ISWL2017)*, Joetsu, Japan, 2017
- S. Vogel and J. Holbøll, "Discharge characteristics in inhomogeneous fields under air flow," in *Nordic Insulation Symposium on Materials, Components and Diagnostics (Nordis)*, Västerås, 2017.
- S. Vogel, M. Ishii, M. Saito, A. Sugita, and D. Natsuno, "Correlations of current parameters with flash density from winter thunderstorms in Japan," in *International Conference on Lightning and Static Electricity (ICOLSE)*, Nagoya, Japan, 2017
- M. SAITO, S. Vogel, M. Ishii, "Relationship between aerological data and characteristics of upward lightning hitting wind turbines in winter," in *International Conference on Lightning and Static Electricity (ICOLSE)*, Nagoya, Japan, 2017

Furthermore, several presentations were given in the frame of the ELITE project:

- S. Vogel, S. F. Madsen, and J. Holbøll, "High Current Full Scale Testing as Fundamental Element to Ensure Wind Turbine Reliability," in *Wind Energy Science Conference (WESC)*, Lyngby, Denmark, June 2017.
- S. Vogel, "Winter Lightning Exposure to Wind Turbines" at *CIGRE WG C4.36 - Winter Lightning – Parameters and Engineering Consequences for Wind Turbines*, San Diego, United States, April 2016
- S. Vogel, "Upward Lightning Attachment Analysis on Wind Turbines and Correlated Current Parameters" at *CIGRE WG C4.36 – Winter Lightning – Parameters and Engineering Consequences for Wind Turbines* Joetsu, Japan, April 2017

1.6 Utilization of project results

The work conducted within the ELITE project have widely broadened the horizon of lightning exposure of wind turbines and associated verification testing. By publishing the outstanding results in the PhD thesis by Stephan Vogel, DTU and GLPS have again set the standard for

lightning research within this area. The collaboration with research communities in Europe and Asia have further enhanced the commercial relationship with customers on these markets, so for GLPS the project has been a great success.

The market for wind is large, and growing in a very high pace in Asia, such that every second wind turbine erected WW is erected in China. These turbines are supplied by traditional European manufacturers, by Chinese manufacturers operating under license agreements, and by Chinese manufacturers producing own designed products. With the increase of activity, the Chinese manufacturers have grown and now provides their own turbines not only to the Chinese market but also to European and other overseas markets. With the professionalism that a growing industry requires, this have led to an immense need of lightning verification testing in Asia.

Throughout the course of the ELITE project, GLPS had been in contact with several OEMs and other companies interesting in establishing lightning test centres in China. So far, we have not found the right partner in this or had the necessary strength to establish a test centre by own means, so we are still solving test assignments in Asia by shipping blade tips (10m sections) to Denmark, and executing tests in our existing facilities.

A few months after the demonstration test of ELITE, GLPS was contacted by a National test center in China with the scope of establishing a full scale lightning verification centre in China. Meetings and discussions on the technical and administrative setup is being discussed currently, and the aim is an operational Joint Venture between GLPS and the Chinese entity. Realizing this setup, enabling full scale testing of blades and nacelles in China, will not only be a valuable expansion of the GLPS testing business, it will also enable the large number of Chinese OEMs to provide turbines with the same quality and performance as the European OEMs. Having the same test standards World Wide (the IEC 61400-24 Ed1.0 has been translated and enforced in China), ensures a more transparent business and provides the necessary evidence of strong blade designs.

1.7 Project conclusion and perspective

The outcome of this project contributes with new knowledge regarding the real lightning exposure of wind turbines which can further increases the reliability and performance of wind turbines in the future. The findings are implemented in a physical test system that can inject realistic current impulses of first return-strokes and continuous currents in full-scale wind turbine components. Current impulses resembling subsequent strokes currents can be injected in partial wind turbine components since the inductance of full-scale items limits the peak and rise-time of the current.

The following bullet points list the main achievements of this project:

- In the frame of the ELITE project, world class lightning research was applied and provided new insight in the real lightning exposure of wind turbines
- The developed ELITE generator provides a flexible impulse generator concept with the possibility to extend the concept to future challenges in the wind turbine and aircraft industry. The test generator can create realistic current impulses that appear in natural lightning situations.
- The funding of the ELITE project enabled us to train experts in the field of lightning research, high voltage engineering and composite technologies which will apply their knowledge in the Danish industry in the future.
- New testing technologies were developed which are used to further improve wind turbine technology
- Some industry partners already purchased full-scale high current tests recently. This is obviously a result of the demonstration test the 9th of October 2017 exposing these new options of verification testing.
- An industrial collaboration has been initiated during spring 2018, to establish a lightning test centre in China, based on the concept of the ELITE generator.