

Final report

1. Project details

Project title	Asterix3
Project identification (program abbrev. and file)	64010-0061
Name of the programme which has funded the project	EUDP
Project managing company/institution (name and address)	Dantherm Power A/S
Project partners	HTceramix, EIFER and CNR
CVR (central business register)	30804996
Date for submission	30-4-2015

Relevant links: Website: asterix3.eu

Table of Contents:

Final report	1
1. Project details	1
2. Short description of project objective and results	2
3. Executive summary	3
4. Project objectives	3
5. Project results and dissemination of results	6
5.1 WP2 – System simulation and Design specification	6
5.2 WP3 – Subsystem Optimization	9
5.3 WP4 - Systems development	11
5.4 WP5 – Testing and validation	14
6. Dissemination	18
7. Utilization of project results	20
8. Project conclusion and perspective	21

2. Short description of project objective and results

Dansk version

Målsætningerne for Asterix3 projektet var at udvikle og optimere proof of concept mikro-kraftvarme systemet I forsøget på at nå følgende mål:

- Elektrisk effektivitet (max) 35%
- Elektrisk effektivitet (gennemsnit) 30%
- Total effektivitet på system på 90%
- Modulations område demonstreret 4:1 på gas input
- 5000 timers kørsel af system
- 10 termiske cykler
- Integration med tilsatsbrænder
- Integration med varmesystem/varmelager
- Systemet skal kunne sende strøm på nettet
- Systemet skal kunne starte op og lukke ned uden brug af forming gas

Selvom vi ikke er lykkedes med at opnå alle disse ambitiøse mål – ser partnerne i projektet, projektet som en moderat succes. Vi har som konsortium opnået væsentligt mere i den sidste del af projektet end vi troede muligt, specielt med de mange forsinkelser i hotbox leverancer og uforudsete problemer vi rendte ind i igennem projektet.

English version

The main scientific and technological objectives of the Asterix3 project were to develop and optimize the Proof of Concept M-CHP system, to achieve the targets summarized in the below:

- Electrical efficiency (Peak) 35%
- Electrical efficiency (Nominal avg.) 30%
- Total efficiency of the system reached values up to 90%
- Modulation range demonstrated of 4:1 in terms of gas input
- Demonstration of 5000 hours of operation
- Ability to withstand 10 thermal cycles
- Integration of an auxiliary heater
- Integration with the heating system and storage
- Injection of AC electric output to the grid
- Ability to start-up and shut-down without forming gas

Even though we haven't been able to achieve all the targets we initially setup for the project the partners view the outcome of the project as a moderate success. We have as a consortium achieved much more in the last part of the project than we thought possible - Especially taken into account the many delays and problems we ran into during the project.

3. Executive summary

See 1.2 Short description of project objective and results

4. Project objectives

The main scientific and technological (S&T) objectives of the Asterix3 project are to develop and optimize the Proof of Concept system, based on improved subsystems, a full automatic control system, and other new features, to achieve the following targets:

- Electrical efficiency (Peak) 35% net AC efficiency
- Electrical efficiency (Nominal avg.) 30% net AC efficiency
- Total efficiency of the system reached values up to 90%
- Modulation range demonstrated of 4:1 in terms of gas input
- Demonstration of 5000 hours of operation
- Ability to withstand 10 thermal cycles
- Integration of an auxiliary heater
- Integration with the heating system and storage
- Injection of AC electric output to the grid
- Ability to start-up and shut-down without forming gas

We have had a lot of challenges during the project- but in the end almost all targets were achieved:

Project objectives and achievements at M48

Project objectives/ targets	Status at M48	Extra comments/explanation
Electrical efficiency (Peak) 35% net AC efficiency	Gross Efficiency measured at EIFER @713 W: 44.7% → Efficiency net: > 40.0% (@PI efficiency of 90%), cf. D5.5	The system at EIFER was not equipped with a grid tied PI, therefore, the net efficiency is a calculated value. It was planned to test higher FU by EIFER, but due to an early end of the test this was not possible.
Electrical efficiency (Nominal avg.) 30% net AC efficiency	Gross Efficiency measured at EIFER @713 W: 44.6% → Efficiency net: > 40.0% (@PI efficiency of 90%), cf. D5.5	The system at EIFER was not equipped with a grid tied PI, therefore, the net efficiency is a calculated value.

Project objectives/ targets	Status at M48	Extra comments/explanation
Total efficiency of the system reached values up to 90%	EIFER has measured a total efficiency of the system to 78,9 %.	
Modulation range demonstrated of 4:1 in terms of gas input	A modulation of 1.8:1 was achieved at EIFER	Modulation of gas input above 1.8:1 could be avoided, thanks to the improved flow distribution inside the stack. Thanks to the new design, which is protected by three patents, the fuel utilization could be increased by 25% from FU = 60% up to FU = 75% at nominal power.
5000 hours of operation	At HTceramix a long-term tests achieved an operation of 4000 h (close to the 5000 hour objective of Asterix3).	The long term tests at CNR failed due to a failure outside the HB.
10 thermal cycles	By HTc more than 10 thermal cycles have been reached, by DTP four thermal cycles have been achieved (during the 200 + hour test).	Due to the unforeseen HoTbox™ breakdowns at EIFER the thermal cycle test was not performed,
Integration of an auxiliary heater	Achieved.	
Integration with the heating system and storage	Achieved.	
Injection of AC electric output to the grid	Achieved.	

Project objectives/ targets	Status at M48	Extra comments/explanation
Ability to start-up and shut-down without forming gas	Two methods have been developed to protect the Ni against oxidation: a. ICCP: also referred to as electrical protection b. SSCP: also referred to as Sub-Stoichiometric Combustion Protection	The ICCP is not implemented on the system. However, the electronic hardware needed is designed and assembled and had been tested by DTP on a different SOFC stack platform. A second option beside the ICCP, the SSCP had been tested successfully at HTc. A measure to reduce the CO content during the sub-stoichiometric combustion have been designed, cf.WP3 chapter.

The associated milestones agreed upon with EUDP are shown in the below and were all met. Due to very delayed hotbox deliveries and problems with the hotbox's when we received them - we ran into serious time pressure in the project. In the end we managed to catch up but unforeseen hotbox breakdowns meant that only 3 – instead of the planned 4 systems were produced and delivered.

Milestone number	Milestone name	Means of verification
1.1	Technical specifications Heat storage	Spec sheet
1.2	Delivery Heat Storage	Physical delivery
2.1	Technical specifications Aux Heater	Spec sheet
2.2	Delivery of Aux. Heater	Physical delivery
3.1	Technical specifications Inverter	Spec sheet
3.2	Delivery of Inverter	Physical delivery
4.1	System simulations as overall input for system design and	Data Sheet
4.2	Technical specifications and operation procedures	Spec sheets
4.3	Delivery of SOFC system generation 1	Physical delivery
4.4	SOFC System gen. 1 testing report	Test report from partners in the project
5.1	Delivery of SOFC system generation 2:	Physical delivery
5.2	SOFC System gen. 2 testing report	Test report from partners in the project

5. Project results and dissemination of results

The purpose of the Asterix3 project were to develop, produce and test a fully automated and integrated SOFC CHP system capable of fulfilling end user demands. In that sense the project have been very technical and no short term commercial targets have been set or pursued.

In the reminder of this paragraph the findings and results in the technical WP's will be presented one WP at the time.

5.1 WP2 – System simulation and Design specification

Main objectives of WP2 (System simulation and Design specification) were:

- Simulate a 2nd generation hybrid system and define system specifications
- Update the system design with simulations including an auxiliary heat pump
- Definition of power conditioning devices specifications.

For reaching these targets, two tasks were defined:

- Task 2.1 - Initial Proof of Concept system specification
- Task 2.2 - System simulations including a heat pump

Task 1 resulted in the definition of the technical characteristics of the system to be developed in terms of power and efficiencies. The study is based on a sensitivity analysis of key parameters such as:

- Load curve of the heat demand (annual profile and value): 2 load curves have been used (16 MWh/yr and 24 MWh/yr).
- Water tank size (from 500 l to 2,000 l).
- Thermal power produced by the system (1 to 5kWth), and electrical efficiency (30% and 35%)

Final results show the influence of these parameters on the number of start/stop of the systems according to their thermal power and electrical efficiency. The table below (from D2.1) shows an example of outputs for a 16Mh annual heat demand.

P_{th} kW	P_{el} kW	η_{el} %	η_{tot} %	EFPH h	S %	NOS (500 l) -	NOS (1000 l) -	NOS (2000 l) -
0.96	0.75	35	80	7700-8600	43	35	13	3
1.18	0.75	35	90	7200-8100	50	53	24	9
1.25	0.75	30	80	7000-8000	52	59	27	9
1.50	0.75	30	90	6500-7400	58	81	38	17
3.21	2.5	35	80	4700-5400	84	213	107	54
3.93	2.5	35	90	4100-4700	94	265	142	73
4.17	2.5	30	80	4000-4500	96	284	152	82
5.00	2.5	30	90	3500-3900	98	356	197	102

Simulation results with specifications of the Asterix III system integrated into a dwelling with low thermal demand (Load 16MWh).

These figures were used to design the proof of concept system (WP3 and WP4).

Task 2 focused on the specifications of the next generation of systems. A previous analysis had shown an important market opportunity for a hybrid technology between a fuel cell based mCHP system and a heat pump technology.

A preliminary study, based on global approach concluded that the expected increase of the total efficiency of the coupled technologies (see figure below) would lead to substantial benefits for the clients.

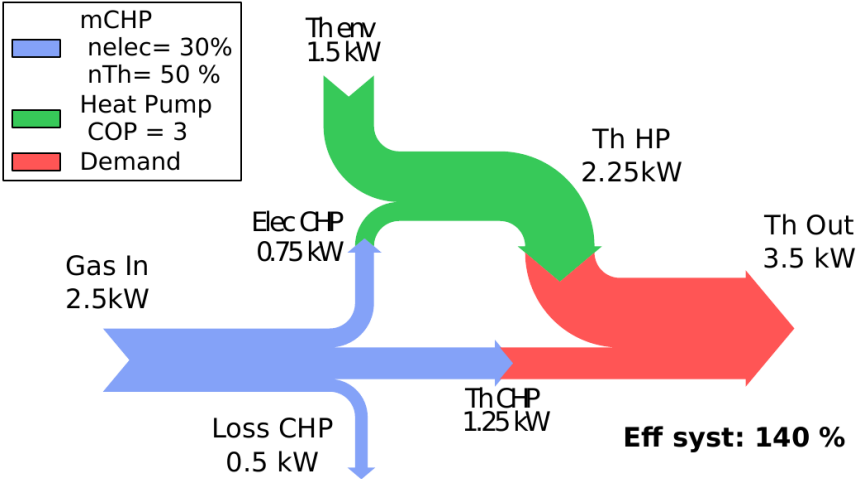

Figure 1: Energy flows in a CHP-HP system

Four scenarios (systems integrations in a single family house with a) were analyzed for evaluating the economic balance:

- Scenario 1: classical scheme with heat production from a condensing boiler, and electricity from the grid.
- Scenario 2: heat demand is produced by a compression heat pump.
- Scenario 3: heat demand is produced by a mCHP system and an auxiliary burner. Electricity produced by the mCHP is used in site, excess production is not sold to the grid.
- Scenario 4: heat demand in the house is provided by a hybrid mCHP-HP system.

The table below shows clearly that the lowest annual energy bill is obtained with scenario 4.

	Scenario 1	Scenario 2	Scenario 3	Scenario 4	
Elec. Import	4.00	7.33	1.01	1.35	MWh
Gas Import	11.11	0.00	16.95	12.81	MWh
Elec. Cost	1080.00	1980.00	272.70	364.50	EUR
Gas Cost	777.78	0.00	1186.50	896.70	EUR
Total Cost	1857.78	1980.00	1459.20	1261.20	EUR

From this interesting result, a detailed analysis was carried out for evaluating the dynamic behavior of a hybrid mCHP-HP system, when different annual heat load profiles (and total annual value) are taken into account. CNR ran calculation with TRNSYS, and considered three different heat pump technologies:

- Electricity driven heat pump.

- Adsorption heat pump.
- Absorption heat pump.

Moreover, the influence of the type of connection between the heat pump and the mCHP was also studied:

- Connection to the evaporator side
- Connection the condenser side
- Connection to the regenerator (adsorption heat pump only).

The simulations concluded to an important improvement of the global performances when the heat pump is connected to mCHP system. The connection to the condenser side appeared to be the most promising configuration for the three types of heat pumps. It was also shown that the most important increase is obtained for the electricity driven heat pump (see figure below).

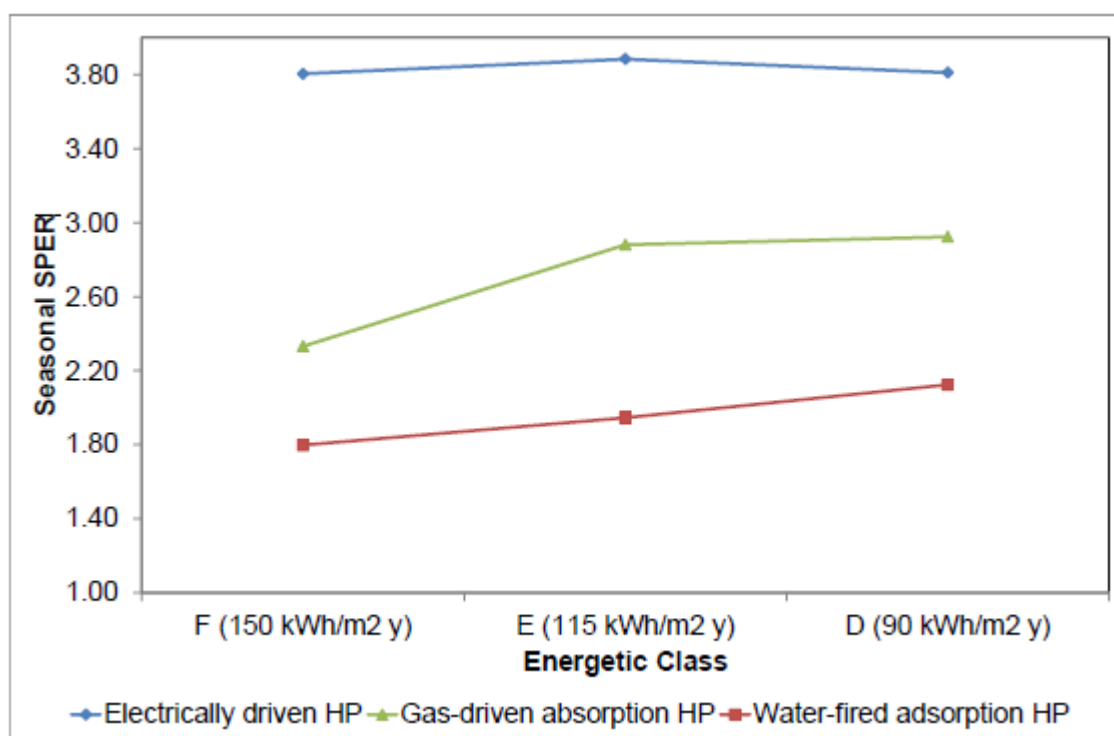

Figure 2: Comparison between the most performing simulated configurations for each heat pumping technology.

The final configuration (FC based mCHP system coupled to an electricity driven heat pump) was then used as reference system for evaluating the economic potential in four European countries (Denmark, Germany, Switzerland and Italy). The evaluation is based on the calculation of the annual energy bills for end customers in two different types of buildings (8.5 and 15 MWh heat demands per year). Local energy (electricity and gas) prices, and subsidies have been taken into account.

The results were also obtained with two different coupling configurations: connection to the evaporator side (configuration I) and the condenser side of the heat pump (configuration II). The comparison is made with the reference system (heat pump only).

The calculations finally show that money savings that can be reached (see figure below), but only in Germany because of generous incentives mechanisms for mCHP systems. However the annual money savings (~€450) are not important to obtain a reasonable payback time, if the current investment costs in Europe for a FC are considered (~€30,000).

An important conclusion of this work is that using global parameters (such as COP or efficiencies) or detailed dynamic simulations for evaluating the economic potential of a technology can lead to very different results. Indeed, on one hand a global approach has shown positive impacts of combining technologies. On the other hand, dynamic simulations show no economic viability despite important performances improvement.

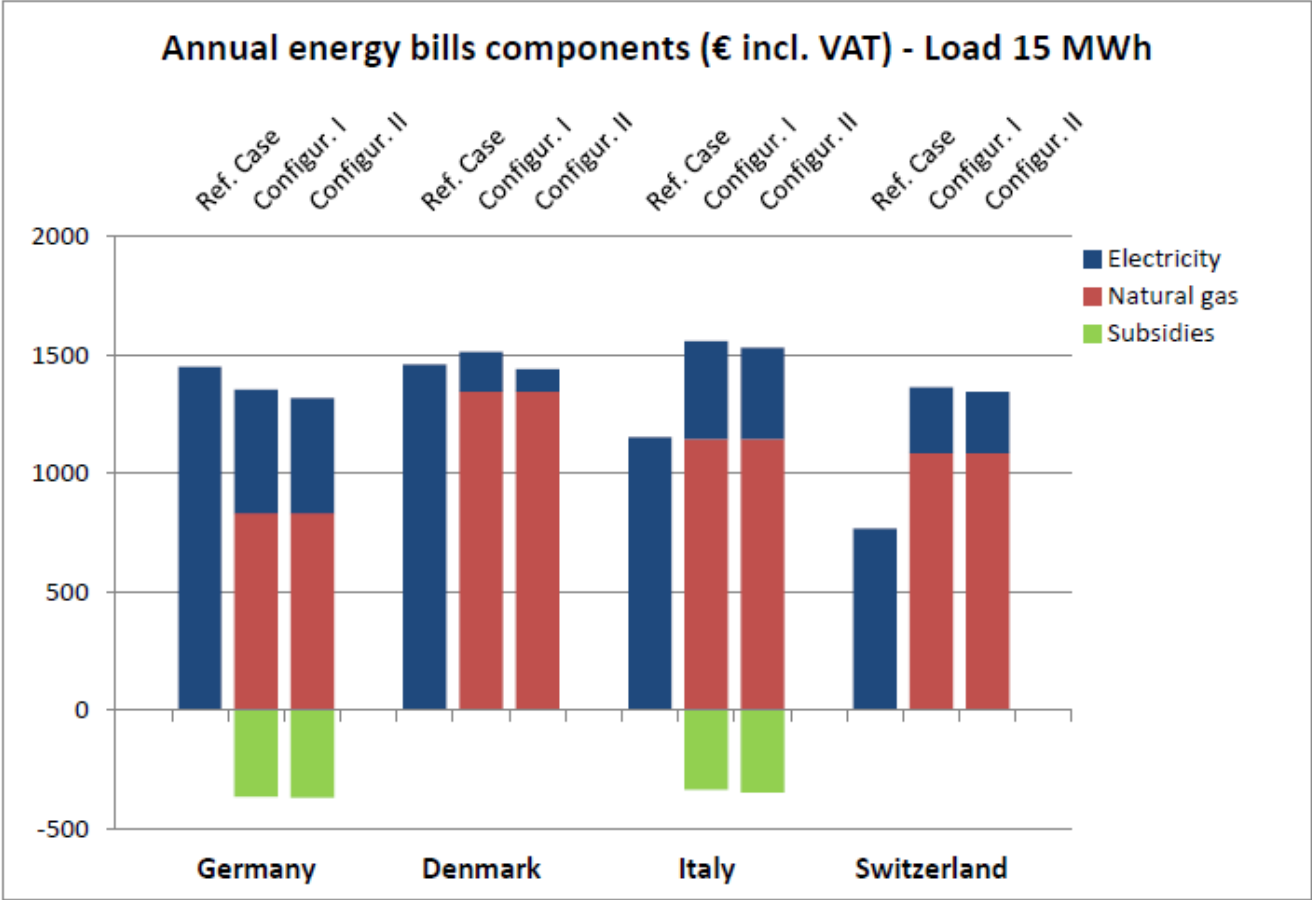

Figure 3: Load 15 MWh –Energy bills components

5.2 WP3 – Subsystem Optimization

The main scientific and technological (S&T) result of the project in the WP3 (“Subsystem Optimization”) is the fruitful feedback, which HTc has received from the partners in the project. S&T results of WP3 have been achieved on different topics:

- Safety
- Handling of Fuel Cutoffs
- Power Electronics
- Stack Design

Safety:

The HAZOP (HAZard and OPerability study) analysis on HoTbox™ (HB) level conducted by HTc on request of DTP has an important impact on the design of a HB in the near future that will be in line with the safety requests, as specified in the relevant technical codes. During independent tests at EIFER it was confirmed that the HB respects the max. limit of NOx and CO contents during standard operation. And at the same time it became obvious during the HAZOP in which way the current HB design needs to be adopted to ensure low CO contents also during system start and shut-down. To achieve this target the post combustion was redesigned in the frame of the project to enforce complete combustion even in the possible situation of a degraded catalyst in the pre-reforming reactor.

Handling of Fuel Cutoffs:

Together with DTP and CNR different measures and strategies have been discussed to handle the situation of sudden fuel cutoffs. If the stack temperature is above 600°C and the fuel flow is interrupted and no counter measures are taken, the Nickel electrode (negative pole / anode) suffers from oxidation. During the transition from Ni to NiO the nickel cement expands more than 30%, which can result in stack failures. A patent research was undertaken by the partners CNR, DTP and HTc. It became clear that the patent protection for the most promising counter measures has expired. More recent patent applications on related topics have often been rejected as patents, as there had often been a lack of new ideas (inventive step and non-obviousness). DTP has already some experience in the approach of electronic Ni-protection, often referred to as Impressed Current Cathodic Protection (ICCP). This technology is well established to protect steel against corrosion in buildings, ships and pipelines. This approach was tested on stack level with HTc short stacks by CNR in the frame of WP4. Other methods use different gases to either dilute or to consume oxygen that might enter the anode department. Medias that can be utilized are for example: Methanol-water mixtures and steam. These strategies have been studied in the frame of WP3. The implementation in prototypes is outstanding. The easiest solution would be to harden the cell against damage by Ni-oxidation. The microstructure of the electrode could be changed to tolerate a Ni-expansion, the thickness of the anode could be reduced further (accompanied by concurrent improving the mechanic cell support inside the repeating element). Steps in this direction have been undertaken in the frame of the project.

Power Electronics:

At the beginning of the project only one power inverter (PI) for low, variable DC voltage inputs had been available on the Western-European market: The well-known SMA “Hydro Boy™”. At that time most of the fuel cell systems had been based on this PI. Unfortunately this product had been discontinued; this resulted in an intensive market research to find an alternative PI on the market. CNR was the leading partner for this task. In the end two prototypes had been found by DTP and one certified small series model HTc. Two of them have been designed as battery PI and only one was designed as a few cell PI. The FC PI was provided by the Danish fuel cell manufacturer IRD. One of the battery PI manufacturer is kept confidential by DTP and the third PI that is already certified, is manufactured by the German company SolarInvent (formerly SWT). The PI from IRD has also been integrated in the Asterix3 system in the frame of WP4.

During tests of this system at HTc it became obvious that the integration of the PI into the FC-system needs to be adopted further to the needs of the SOFC-stack. One aspect needs to be ensured:

A temporary problem at the PI needs to initiate a smooth transition from grid-tied mode to island mode, without system shut-down.

Another point of interest is the impact of the PI on the lifetime of the stack. The PI adds a noise to the DC signal, also referred to as ripple, and this ripple could fasten the degradation of the stack. Further tests with real stacks and PI needs to be conducted to enlighten this aspect.

Stack Design:

The most significant S&T result has been achieved on stack level. Two stack related patents have been filed by HTc and have been accepted. A third patent application is in preparation. The two patents protect the media distribution ideas and the third will protect ideas to improve the stack sealing. These patent ideas have been implemented in the frame of the project into the Asterix3 stack design. By means of these inventions the fuel utilization (FU) on stack level could be increased above values of 70%, high FU is the key factor to increase the electrical efficiency of the stack. Other measures have improved the robustness of the stack against vibration and thermal cycles. The objective of 10 cycles per year seems to be realistic with the new design.

5.3 WP4 - Systems development

A total of three systems are built

System 1 is built as a prototype and sent to EIFER for testing. The system was equipped with load bank instead of DCAC Inverter, to promote the work of the project because intended DCAC Inverter was not finished

System 2 and 3 are built as second generation systems with integrated DCAC Inverter.

Due to hotbox delays and time pressure, the electrical anode protection is not implemented on system`s (However, electrical anode protection is designed and components for anode protection are made.)

One of the systems is sent to the HTceramix/SOFC POWER for further testing, while the second system will be in Dantherm Power lab. Both systems are equipped with DCAC Inverter.

The Dantherm Power system is tested as a micro-CHP system which is briefly described in the below:

Micro- CHP system test

A condensing boiler was installed the in Dantherm lab, as would in a private house. The Asterix system was in- cooperated with the boiler, and heat output performance tests were made.

Temperatures development on the heat exchanger during the test in the lab	Output temperature is controlled by increasing or decreasing the water flow circuit
---	---

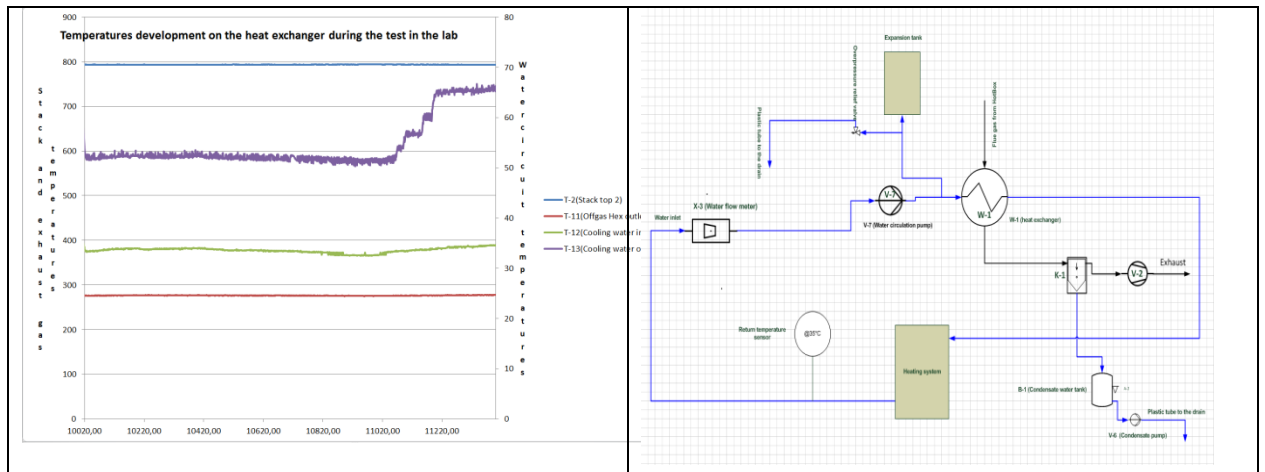

The test was successful and the Asterix3 system can work as a micro CHP system.

System design and development

Design of the system is complete and ready to be used to produce systems.

System is integrated into a gas-tight cabinet.

Air intake and exhaust gas outlet proceeds via the balanced flue pipe dimensions 80/125 mm

The overall system specifications are as follows:

System specification

General

Dimensions: 1780 x 800 x 600 [mm] (H x W x D)

Weight: 326 [kg]

AC power connection

System supplied with AC power via the IEC connector on the back of the system. The same connection is used to supply power to the grid.

Fuel supply

System supplied via Standard ½ "pipe stub with male thread (BSPT). System is designed to use natural gas or methane gas, inlet pressure 25 [mbar]

Forming gas supply

Forming gas is supplied to the system through standard quick-disconnect coupling with integrated check valve. Forming gas flow is adjustable between 5 and 30 L / min, (3 Asterix use 15L / min)

Cooling water connections

Standard ½" pipe stubs with male thread BSPT

Exhaust connection

The air inlet and exhaust gas outlet is through standard flue pipe dimensions 80/125 mm

Condensate outlet

The condensate outlet of the system is through the 6 mm flexible tube that can be directly fed to the drain

Water circuit relief drain

Performed with 12 mm plastic hose on the back side of the system

Condensate drain from the flue

Through 12 mm plastic tube on the back side of the system

Internet connection

Via standard RJ45

Control computer

The system is equipped with a Beckhoof computer



Picture shows Asterix system ready for use

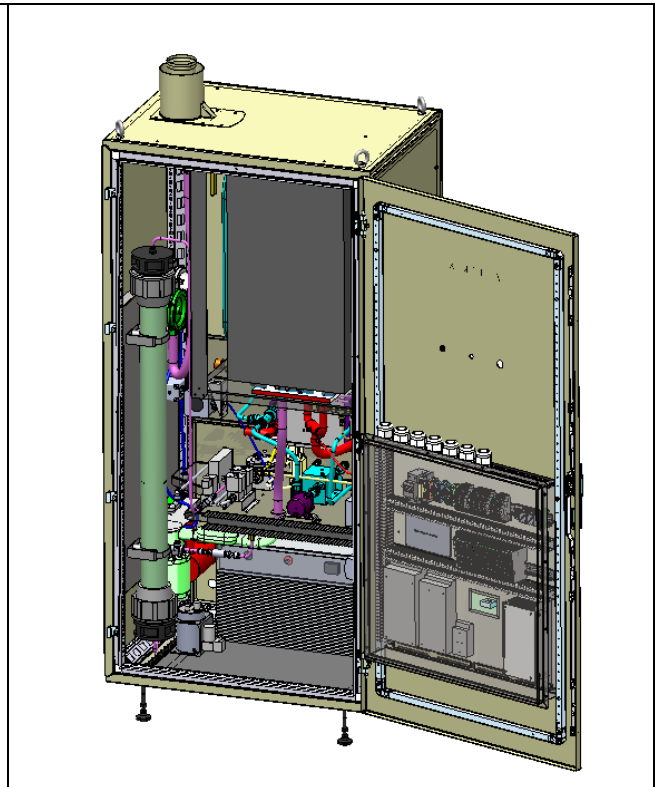

Picture shows Asterix system taken from Auto CAD

Fuel cell control system

Based on the input from HTc, Dantherm has developed a full control system for the fuel cell system based on PLC technology and with a special setup for the chosen inverter.

The IO list has been provided, all hardware has been designed, software has been programmed, and the control system has been built, installed and tested.

HAZOP

In cooperation with HTceramix, a HAZOP is prepared for the system.

HAZOP in-cooperates the use of forming gas as the anode protection.

This means the safety chain on the system, is designed to take into account, that forming gas is used as the anode protection.

If electric anode protection should be implemented, HAZOP and safety chain needs to be revised, to always ensure that personnel and equipment do not suffer damage.

As an inspiration to find parameters for the risk assessment clause 4 of IEC 62282-3-300 have been used.

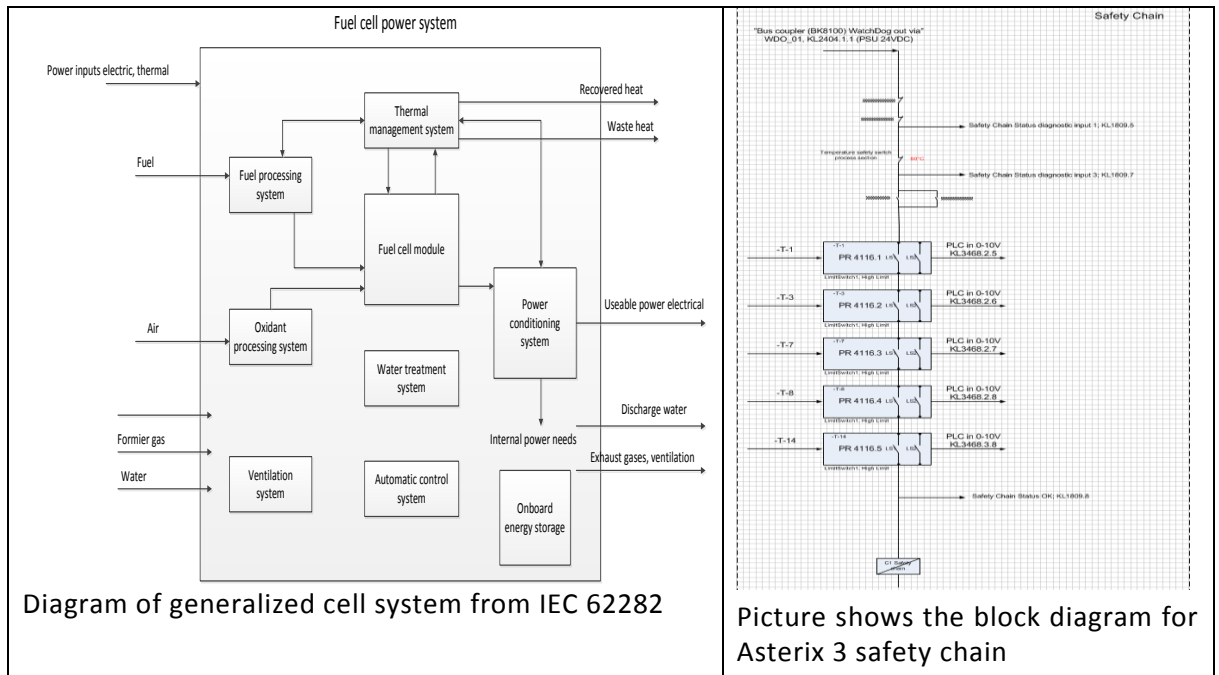

Diagram of generalized cell system from IEC 62282

Picture shows the block diagram for Asterix 3 safety chain

Documentation

The 2 systems Dantherm Power have sent to EIFER and HTceramix have been accompanied by the following documentation:

- HAZOP on the system
- Installation guide
- Software guide
- Document on how to dismantle the hotbox
- Startup procedure Asterix3;
- Thermocouple connector assembly
- Safety aspects of Asterix III in emergency

5.4 WP5 – Testing and validation

The objectives of this work package are:

- To define experimental program and establish optimal operation process
- To show the general capabilities of the Asterix m-CHP appliance.
- To demonstrate extended continuous operation.
- To validate operating performance of key system components.
- To demonstrate operation and system response under start-up, power cycling, thermal cycling, and normal and emergency shutdown conditions.

Because of the major technical and strategic changes that occurred during the project, it has not been possible to test two generations of systems at EIFER and at CNR. These changes have had also a strong impact on the content of the different tasks in this work package.

However, the partners agreed each time on a common position, and this resulted on the assembling of a system which was tested at EIFER in October 2014. Two stacks have been tested at CNR.

The main objectives of WP5 were reached. Indeed, the system and the stack tests resulted in a complete evaluation of the system as a potential micro-CHP appliance, and technical improvements have been identified.

Prior to these tests, a test procedure has been written (D5.1). The document presents the conditions for the different tests. The different measurements are also described.

D5.1 consists of a detailed presentation of:

- The global context of the tests.
- The planned schedules.
- The safety procedures and related documents.
- The applicable international standards for the testing of fuel cell based micro-CHP systems.
- The technical characteristics of the system and its different components.
- The different measurements and their accuracy.
- Different types of tests: start mode, steady state, dynamic tests.

According to this procedure, the tests benches have been adapted and validated. Deliverable D5.2 presents the test benches used at EIFER for testing the system, and at CNR for testing two HotBoxes™ delivered by HTC. The figure below shows a scheme of the test bench at EIFER, and details the location of the measurements.

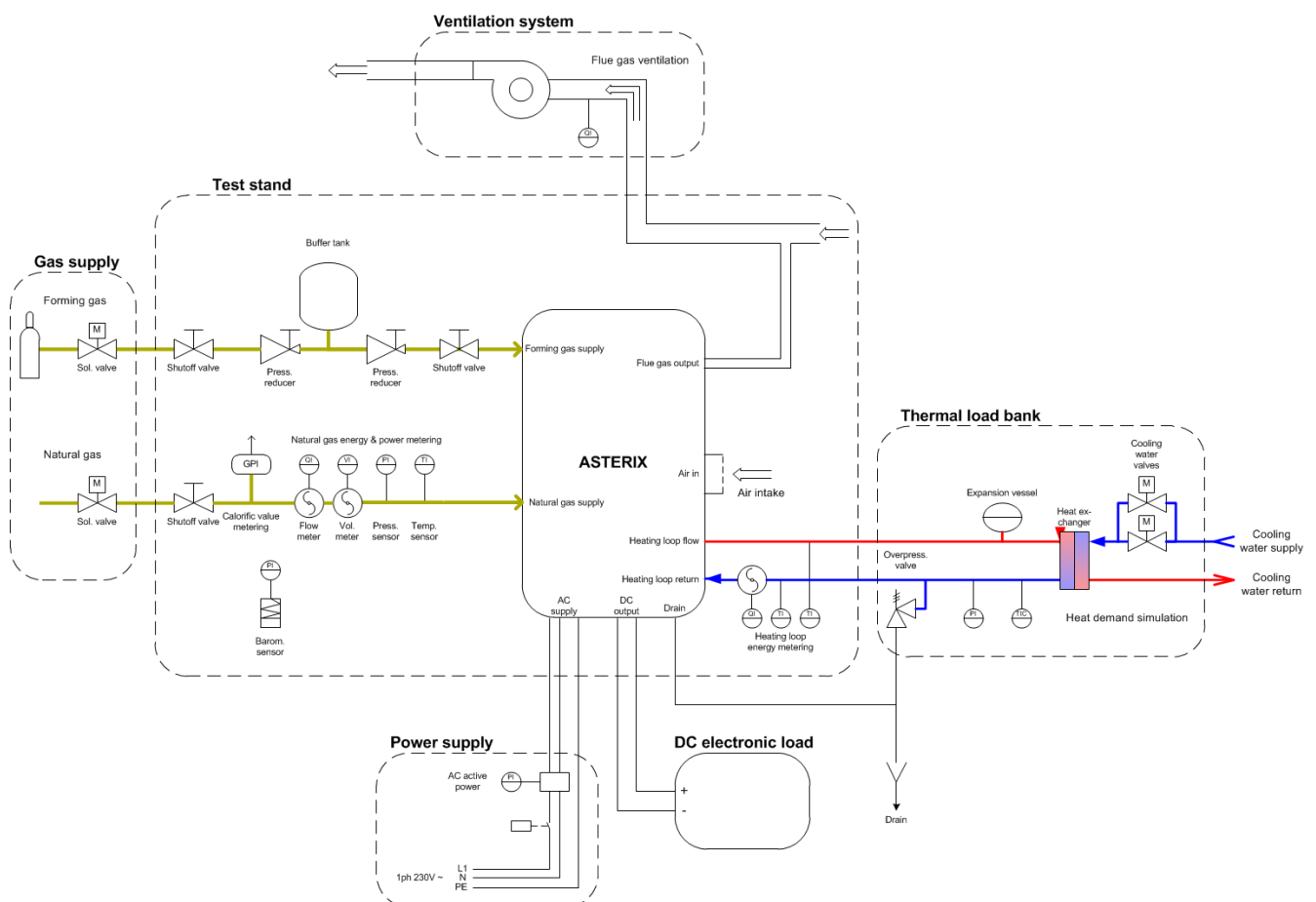

The picture below shows the system ASTERIX 2 used as a platform for testing the HotBox™ at CNR.



The system has been assembled by DANTHERM POWER (D5.3) and the staffs have been trained before system's commissioning (D5.4). After verification and analysis, the results (powers, performances, flue gas emissions) were reported in a final document (D5.5).

As an example, the table below contains the main results obtained during the steady state tests.

Current level [A]	5	10	15	15
Return temp set point [°C]	30	40	30	40
Measuring time [hh:mm:ss]	00:56:40	06:41:30	03:00:30	06:00:10
Measuring time [s]	3400	24090	10830	21610
Consumed gas volume [m ³]	0,09	0,99	0,51	1,02
Average gas flow [m ³ /h]	0,095	0,148	0,170	0,170
Average LHV [kWh/m ³]	10,04	9,99	10,02	10,01
Average HHV [kWh/m ³]	11,11	11,06	11,10	11,09
Average Z	0,944	0,939	0,939	0,940
Average gas power LHV [kW]	0,903	1,388	1,596	1,599
Average gas power HHV [kW]	1,000	1,537	1,767	1,771
Average flow temp [°C]	39,3	60,7	50,8	58,1
Average return temp [°C]	29,9	38,9	29,7	39,1
Average delta T [°C]	9,4	21,8	21,0	19,0
Average flue gas temp [°C]	43,1	47,5	43,3	48,2
Average heating loop flow [lpm]	0,84	0,46	0,54	0,55
Average thermal power [kW]	0,545	0,689	0,793	0,719
Average active power consumption [kW]	-0,238	-0,241	-0,248	-0,253
Average reactive power consumption [kW]	-0,185	-0,198	-0,192	-0,205
Average active power DC [W]	227,1	517,3	713,0	713,0
DC Electrical efficiency LHV [%]	25,2	37,3	44,7	44,6
Thermal efficiency LHV [%]	60,3	49,7	49,7	44,9

Electrical efficiency LHV [%]	-1,2	19,9	29,1	28,8
Overall efficiency LHV [%]	59,1	69,6	78,9	73,7

Due to delays and an unfortunate accident we did not have time for a long testing phase. However, the tests' duration was important enough to establish a list of recommendations for making the ASTERIX 3 system a m-CHP system, and in order to reach the initial targets of the project.

The tests carried out by CNR on two stacks are also included in D5.5. As an example, the trend of the efficiency function of the power of the 1 kWe and 500We Hot-Boxes™ is respectively shown in the figures below.

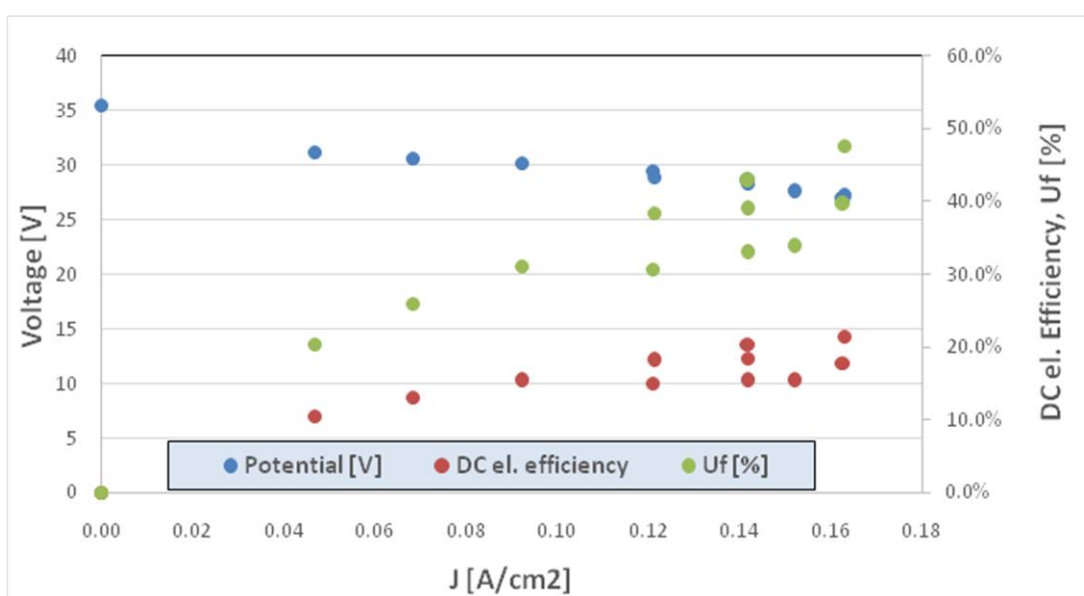
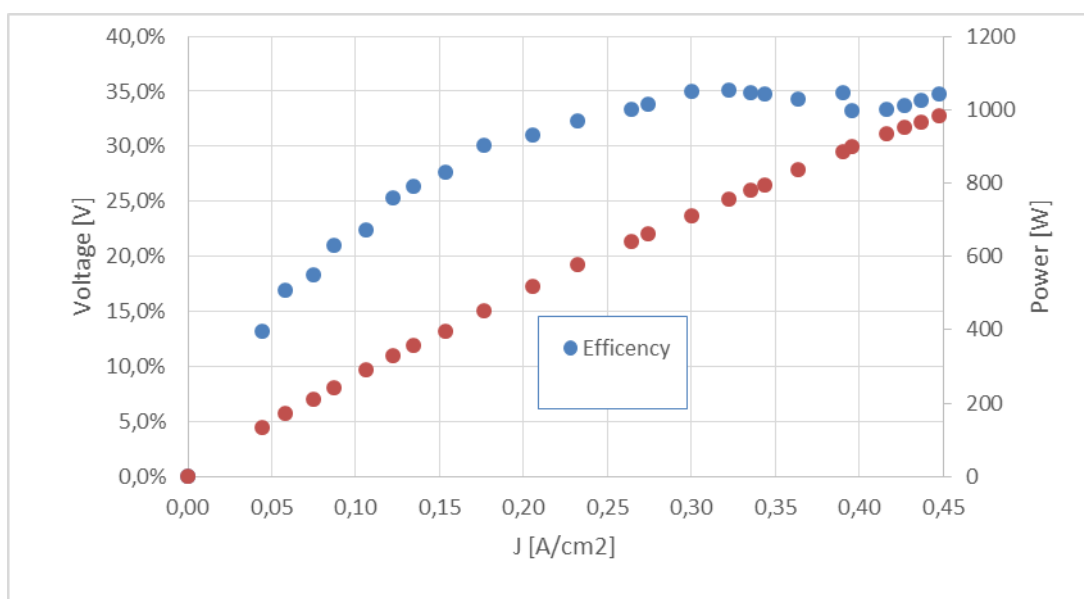

After the different tests performed at EIFER and CNR, it became clear that the initially expected results in terms of performances (efficiencies, tests duration) and system de-

velopment have not all been reached. For this reason, recommendations and remarks have been made on the following aspects:

System integration, components, Hotbox™, System controls and efficiency evaluation.

6. Dissemination

The dissemination activity in Asterix3 project was pursued through a website: asterix3.eu , a dedicated booth (reporting project conclusion) at an international conference, and scientific publications (articles, presentations).

Two dedicated events were successfully organized. The former was held on January 2012 in Roncegno Terme (Italy) focused on Fuel Cells based micro-CHP status and perspectives and a visit to the installation of three systems equipped with HB500 in an island configuration, Figure 1.

A second event was held in Taormina, Italy (December 2014). It was organized in the framework of the EmHyTeC 2014 *Euro-mediterranean Hydrogen Technologies Conference* (see Figure 2) and gathered more than 150 attendants and 105 presentations were delivered (a total of more than 200 people, including students and other visitors).

Interesting comments and questions from the audience followed.

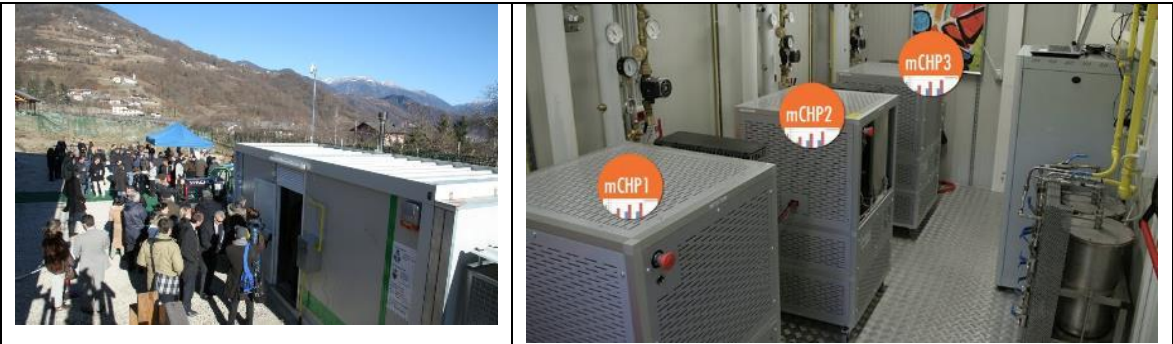

Figure 5 – project workshops held in Roncegno Terme (2012)



Figure 6 – The Asterix 3 booth at the EmHyTeC 2014 Conference (left) and the first day Key note session (right)

Posters summarizing the Asterix 3 results are reported in the following figures 6a, 6b, 6c, 6d, and 6e.

Asterix3

Assessment of SOFC CHP systems built on the technology of HTCeramic

Purpose:

The Asterix3 project aims to develop a proof of concept micro CHP system based on SOFC technology with progress beyond state of the art and towards the market requirements.

The requirements are used to create a design specification for all subsystems and finally for the Proof of concept system. Each separate subsystem has its own set of objectives that is simulated and optimized for the proof of concept system in order to reach longest possible lifetime, high system efficiency and the ability to compete on investment cost with traditional technologies.

Partners

Dantherm Power, DK
HTCeramic, CH
EIFER, DE
CNR-ITAE, I

Website: <http://asterix3.eu>

Budget: 3096 K EURO
FCH JU contribution: 1361 K EURO
Danish EUFP: 180 K Euro

System anno 2010



System during development



System ultimo 2014

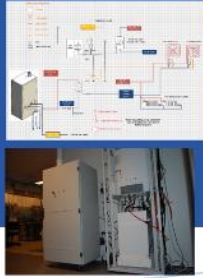

WT 3.3 - Inverter tests

Three different inverters were tested by using oscilloscope measurements to obtain information about the connection to the public grid (frequency and phase synchronization) and its compliance to national and international standards.



The test rig was designed by using a digital oscilloscope (Rohde & Schwarz FDS1000) equipped with current active probes working in a frequency range from DC to beyond 1MHz to accurately and synchronously sample current both at DC and AC side of the inverter; a proprietary software developed by the test rig provider was used to measure DC voltage at selected power levels.

However, to analyze the AC side behaviour and inverters even during transients, the proprietary software was used to record DC side variables, and the oscilloscope was dedicated to AC side voltage and current.

The transient behaviour was highlighted by suddenly changing fuel cell power, and observing the phase difference between voltage and current at the AC side of the inverter.

Efforts at Dantherm Power on testing inverters have been rewarded with other efforts on power electronics. Efforts have focused on functional testing of AC inverters on off the shelf inverter topology, which includes voltage ripple, heat having potential to meet short-term test targets and a prototype of a dedicated fuel cell inverter.

• Actual current, synchronously input voltage as parameter and dynamic response
• The test identified current behaviour in using of the parameter "dynamic response" and if number of functionalities will have to be developed Power law + GND approach on AC side (selectively related)

For the dedicated fuel cell inverter functional test have shown that required functionality can be achieved: the inverter has successfully injected 3 kW of power produced from a fuel cell in 70-90 VDC range to the lab inverter regulated by a speed set point (communication protocol).

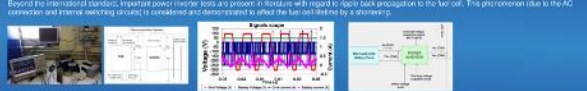

Reversed Current for the Prevention of Anodic Oxidation during exposure to Air: "ICCP Test"

To prevent the stack in case of sudden shutdown (e.g. fuel feed interrupted) different techniques can be applied. These techniques are based on materials or system development. Among the systems based on materials, the ICCP (Inverted Current Cathodic Protection) reverse the polarity of the SOFC stack during the shutdown. (See working on electrolyte study)

In reversed operation a maximum cell voltage of 1.87 V (at 750 - 800 °C) is reported by J. Schindler et al. (2008). Above this value the electrolyte might be destroyed. Moreover, it is necessary to ensure a potential at the anode above the decomposition equilibrium voltage (value in the range of 0.58 - 0.73 V).

The stack used for the tests was a polar SOFC designed with nominal power of 100W, consisting of 7 cells with an active area of 48 cm² for each cell. The current and potential actively allowed to find a suitable voltage (1.03V) that, internally, applied to avoid anode reoxidation during the intended repositioned situation.

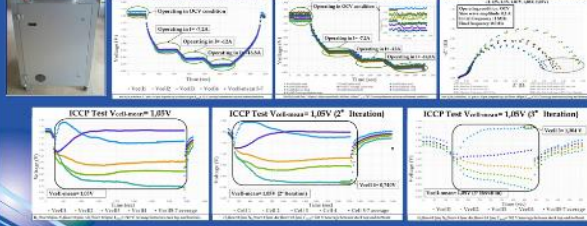

Figure 1: ICCP Test Voltage-LHV (Iteration 1), (Iteration 2), (Iteration 3)



Lab analysis of the Asterix III system

Yannick Monnard, Niklas Griesbaum, Alberto Martinez, Christian Schraube
European Institute for Energy Research (EIER)



Introduction

The Asterix project was initiated as a priority financed initiative in 2005 between EIER, ECF, Dantherm, Danfoss and HTCeramic. The objective was to evaluate HTCeramic's SOFC technology in perspective of development of a residential and light application with a well defined market focus. The target of the lab test was a thorough analysis of the behavior of the SOFC in real application.

Steady state performance

Steady state system tests were carried out for varying operation points. Due to an unforeseen shutdown (see section below) only a limited number of operation points have been tested. A summary can be found in the table below:

Parameter	Unit	5	10	15	20
T_{stack}	°C	39	40	39	40
P_{el} [DC]	kW	0.297	0.517	0.713	0.713
η_{el} [DC] [LHV]	%	28.2	32.3	44.2	44.6
η_{el} [LHV]	%	12	19.4	28.1	28.8
η_{el} [H ₂]	%	60.5	49.7	48.7	46.9
η_{fuel} [LHV]	%	32.1	38.0	38.9	33.7

System description

Prior to testing, the power and efficiency was estimated as following:

Parameter	Value
Maximal gas input [LHV]	2.5 kW
Minimal gas input [LHV]	0.28 kW
Maximal gas input [H ₂]	1.05 kW
Max electric power	0.7 kW
Modulation range electric	0.2 kW to 0.8 kW
Nominal thermal power	1 kW
Expected DC electrical efficiency	46%

Unforeseen shutdown

An uncontrolled shutdown triggered the early end of the experiments at EIER labs. It was caused by a blockage on Saturday (2011-10-04), as a result of malfunction of the laboratory smoke detection system. The EIER engineer was present in the lab about 2 hours after the blockage, where he realized that the forming gas pressure and flow was below specifications.

System Start-up

The system required 4 hours 10 minutes of dynamic loading to reach 300 °C at an active point the cathode.

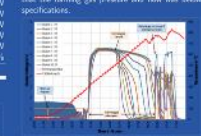

Figure 2: Stack temperature and natural gas flow during the start-up



Figure 3: Water and gas inlets in Asterix III system



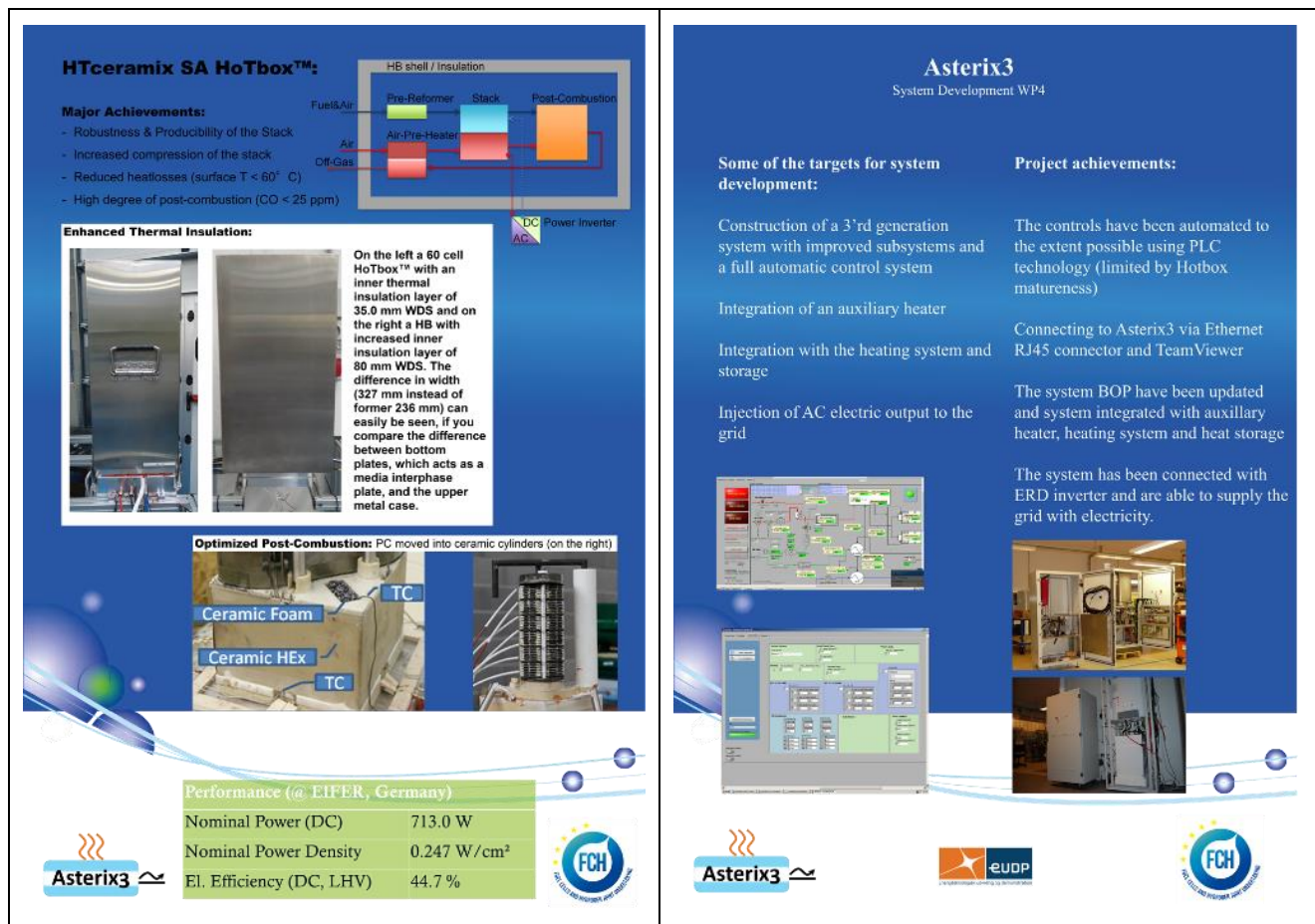

Figure 6. Images (a, b, c, d, e) of the posters displayed at the EmHyTeC 2014 Conference in Taormina.

Moreover, during FCH-JU programme review days 2011, 2012, 2013, 2014 the project status and preliminary results have been reported by presentations and posters.

- 22nd November 2011: oral presentation at FCH-JU Review Day 2011 in Brussels (by Per Balslev, Dantherm Power);
- 28th-29th November, 2012: oral presentation at FCH-JU programme review day 2012 in Brussels (by Per Balslev, Dantherm Power and Olivier Bucheli, HTceramix)

In the FCH-JU programme review days 2013 and 2014, the projects activities were presented in the poster session.

7. Utilization of project results

It is no secret that we in Dantherm Power are disappointed with the functionality and stability of the HTceramix Hotbox. There are a number of issues that have to be sorted out on Hotbox level – before it will be interesting for Dantherm Power to continue working with the Hotbox technology. Therefore the integration work on the Hotbox is put temporarily on hold. If and when these issues are sorted out the future development path will look like this:

The outcome of this project will after the identified Hotbox functionality errors are fixed enable us to demonstrate a concept fulfilling market requirements within a short period of time following the release of the next Hotbox version, and will enable us to move to the next steps of field test readiness, together with a scale up in production and cost optimization. This development path also implies a large number of demonstration units in field trials.

HTceramix and Dantherm notice a clear interest from B2B customers to install small (0.7 – 1.5 kWel) CPOx based SOFC systems with anode supported cells in larger numbers in the field for specific, dedicated applications. Besides the classical single house heating also other applications are currently in the testing phase.

We hope to become commercial from 2017-19, But it all depends on when we can live up to consumer demands, regarding price and dependability.

8. Project conclusion and perspective

Even though we haven't been able to achieve all the targets we initially setup for the project the partners view the outcome of the project as a moderate success (we refer to paragraph 4: Project Objectives). We have as a consortium achieved much more in the last part of the project than we thought possible - Especially taken into account the many delays and problems we ran into during the project.

If and when the Hotbox producer fixes the identified problems we can relatively fast upgrade the system, CE mark it and get ready for a phase with field trials.

Whether or not this happens the learning's from this project will be utilized for our future developments within LT PEM CHP systems.