

Annex X Final report

Toward 4th Generation District Heating: Experience and Potential of Low-Temperature District Heating

Short title: Toward 4th Generation District Heating

Date of Publication:2019-04-01

Authors: Alessandro Dalla Rosa¹, Hongwei Li¹, Svend Svendsen¹, Sven Werner²,
Urban Persson², Karin Ruehling³, Clemens Felsmann³, Martin Crane⁴,
Robert Burzynski⁴, Ciro Bevilacqua⁵

1. Technical University of Denmark: Project leader and editor
2. Halmstad University, Sweden
3. Dresden University of Technology, Germany
4. Scottish&Southern Energy, United Kingdom
5. Building Research Establishment, United Kingdom

Annex X Final Report: Toward 4th Generation District Heating



Annex X Final Report: Toward 4th Generation District Heating

This page is empty on purpose.

Executive Summary

Background and Objective

The evolution of district heating (DH) has gone through three generations which are characterized by the type of transport media and the network temperature levels: the 1st generation DH system is steam-based system, the 2nd generation DH uses high network supply temperature above 100°C, and the 3rd generation DH represents the current DH system with medium network supply temperature between 80°C to 100°C. Up until now, the 4th generation DH as the low-temperature district heating (LTDH) is emerging as a new system which is going to replace the existing 3rd generation DH system. Comparing with the existing DH system, the LTDH reduces the network supply temperature down to consumer required temperature level, thus greatly improves the quality match between the energy supply and the energy demand. Meanwhile, LTDH coupling with reduced network temperature and well-designed DH network can reduce network heat loss by up to 75% comparing with the current system. This makes DH economically competitive comparing with local heat generation units in the areas with low heat density or with low-energy buildings.

The traditional approach to evaluating a DH system often focuses on the production/supply aspect and only afterwards on the final users. The LTDH concept switches the perspective, starting from end-user thermal comfort and a quality match between energy supply and energy consumption, and aiming to find the best and most economical way to satisfy the heat demand through efficient distribution networks and supply systems based on waste heat and RE. The new concept therefore starts by identifying suitable in-house substations for low-energy-demand buildings at low supply temperature, goes back to design efficient and reliable networks, and finally considers environmentally-friendly heat production units.

This report describes the concept of LTDH, collects and discusses successful examples of implementation LTDH in the building heating sector. The objective of this report is to raise awareness and provide insights that will stimulate the research, development and implementation of LTDH systems. It will help to increase public recognition and assist policy makers and energy planners, both at local and governmental level, in promoting cost-effective and environmentally friendly DH systems, and in planning and realizing long-term sustainable urban area development. To this end, the report addresses the following research issues:

1. What are the main advantages of LTDH?
2. What technology options are available for LTDH, and what are the associated challenges to consider?
3. How can the risk of Legionella be mitigated in LTDH?
4. What lessons can be learned from early LTDH projects?
5. What heat distribution costs are associated with LTDH?

Content of the Report

In this report, the relevance of the new generation DH concept is emphasized and the related technologies are described. The report consists of the following chapters mainly dealing with the relevance of LTDH, the building installations required, the supply of LTDH to both low-energy buildings and existing buildings, and the optimal design of a DH network and the heat sources.

In chapter 1, the basic terminology used in the report is presented. The background, objective and the structure of the report are described. The five basic research issues are stated.

In chapter 2, the role of DH is discussed with respect to the specific distribution cost, the strategic planning of DH in the overall energy system for a future low-energy-demand society, and the balance between investment for building energy reduction and renewable heat source exploitation.

In chapter 3, the DHW regulations that address potential Legionella issues are summarized. Statistical analysis of Legionella contamination in DHW installations is presented. Various types of Legionella treatment method are discussed, and proper design methods to reduce the risk of Legionella in single-family houses and multi-storey buildings are introduced.

In chapter 4, various types of DH substation specifically designed for low-temperature operation for single-family houses and multi-storey buildings are introduced.

In chapter 5, the supply of LTDH for low-energy buildings is discussed through building performance simulation, with emphasis of the consumer thermal comfort and the internal heat gain.

In chapter 6, the potential to supply LTDH for existing buildings is evaluated. Various building renovation strategies are suggested to fit the low-temperature operation.

In chapter 7, the performance of energy-efficient DH networks with pre-insulated flexible twin pipes is examined and the idea of optimal network design and operation is discussed. Strategies to reduce network bypass heat losses are illustrated, and the concept of the Comfort Bathroom is introduced.

In chapter 8, the use of a renewable-energy-based energy conversion system is discussed. The concept of using heat pumps (HPs) for DHW preparation inside residential buildings and for DH network integration of two different temperature levels is discussed.

In chapter 9, the experience from early LTDH projects around the world is drawn upon with regard to efficient low-temperature supply, the integration of low-energy buildings, and renewable energy supply. A short comparative analysis is carried out with existing MTDH systems with respect to performance indicators and heat distribution costs.

In chapter 10, the concepts and technologies for the new generation LTDH system are summarized by providing our answers to the research issues we started with.

Final Conclusions

LTDH Advantages

The main advantages of LTDH in heat distribution are reduced heat losses, improved harmonization between heat supply temperatures and heat demand temperatures, reduced thermal stress in steel pipes, the possibility of using other pipe materials, reduced boiling risk, and reduced risks for scalding.

The main LTDH advantages in heat supply are improved power-to-heat ratios in steam CHP plants, greater heat utilization from flue gas condensation when using fuels with moisture, higher coefficients of performance in heat pumps, greater utilization of low-temperature industrial excess heat, increased utilization of geothermal heat, higher conversion efficiencies in central solar collector fields, reduced heat losses, and greater utilization of thermal storage.

The current barriers for LTDH are high-temperature heat demands, legionella growth at low hot-water temperatures, substation faults, and shortcut flows in distribution networks.

Planning and Technical issues

The Planning of DH

DH systems have a long lifetime and can be operated with a strategy that combines reduced network supply temperature with extension to adjacent areas which are supplied with individual heating units. The profitability of extending an existing DH network and the threshold for DH market share can be indicated through the specific distribution cost.

To find an optimal energy supply structure and identify the role of DH in the energy supply system of the future, a strategic energy planning approach can be applied to optimize the entire energy infrastructure to achieve the target for a low-carbon economy and minimize total long-term investment.

The transition from current DH systems to the next generation DH system requires coordinated efforts for building energy reduction and wide exploitation of low-grade waste heat and RE. With a significant building energy reduction, the heating demand will be levelled out throughout the year, which means DH utilities profit from savings in peak-load facility investment. The level of building energy saving and the reduction in renewable-based heating plant installed capacity will depend largely on the decisions on socio-economic criteria made by policy makers through regulations and incentives.

In-House Substations

A well-designed and functioning DHW system must fulfil the requirements for hygiene, thermal comfort and better energy efficiency. One of the major barriers to implementing LTDH is the increased Legionella risk with supply temperatures close to 50°C. In small residential buildings, the DHW system can be operated below 50°C without using external treatment or recirculation if the water volume in each DHW supply line, including the water content on the secondary side of HE, can be limited to 3 litres. The same design philosophy can be used in multi-storey buildings if a station unit is installed in each apartment.

Annex X Final Report: Toward 4th Generation District Heating

There are different types of in-house DHW installations, typically including DHSU or IHEU. Storage tanks have the advantages to shave the peak heating load and allow a reduction in the diameter of distribution pipes, such advantages should be further justified by considering the size of the tank and using a more realistic simultaneous factor to design the distribution pipes. IHEU is a comparatively simple and cost-saving solution. It has better cooling than DHSU. The negative side of IHEU is that it has larger service pipe diameters. Meanwhile, novel HEs with an increased unit heat transfer rate and more accurate fast-response thermal control is required for LTDH.

LTDH Supply to Residential Buildings

The low-temperature SH system should be selected to fit the low-energy building demand with regard to various criteria such as energy consumption, the ability to shave the peak heating demand, the network return temperature, and consumer thermal comfort.

The large-scale implementation of LTDH relies on its use in existing buildings. The studies show that with the aid of varying network supply temperature and light building renovation, it is possible to supply LTDH to existing buildings prior to extensive building renovation.

DH Network

To reduce the network heat loss, which accounts for a significant portion of annual operational cost, the performance of the advanced pre-insulated DH twin pipes designed for high pressure in the distribution network has been studied. Triple pipes which can deliver supply water with two different diameter pipes and at two different temperature levels were suggested for service pipes to reduce pipe heat loss. Alternatively, they can be used for the 'minimum cooling' bypass strategy.

The operation of a DH system normally has a much higher relative heat loss in summer than in winter due to the use of thermal bypasses. The Comfort Bathroom concept redirects the bypass water through bathroom floor heating, which on one hand improves consumer thermal comfort and on the other hand further cools the bypass water.

Heat Sources

The use of the various forms of renewable energy should be evaluated in the local energy framework, taking into account heating, cooling, electricity and transportation. The development of DH will move from the highly hierarchical, large-scale heating plant heat generation towards small-scale, more flexible and more controllable decentralized heat generation. The energy at different temperature levels will be used in a cascade way to match different energy demand requirements. To further reduce network heat loss, the DH supply temperature can be reduced to ultra-low level and boosted on-site or close to the consumption point with the aid of heat pumps.

Legionella issue

One of the major barriers to implementing LTDH is the increased Legionella risk with supply temperatures close to 50°C. A literature survey was conducted for this report to identify DHW supply

Annex X Final Report: Toward 4th Generation District Heating

regulations around the world. We have reported a statistical study on the growth of Legionella in different DHW installations at different temperature levels. Various treatment solutions have been introduced to reduce or eliminate Legionella bacteria.

Lessons learnt from early projects

The main lessons learnt from the case studies are:

Generation compatibility: Fourth generation technology requires the application of more realistic and accurate design conditions with respect to heat demands, costs, and operating conditions. It is also possible to extend traditional networks into new areas using fourth generation technology.

Temperature level: The design and operation of low-temperature in DH network requires customer heating systems with low temperature demands, no shortcut flows in distribution networks, and continuous commissioning of the systems to identify new faults that give higher temperature levels.

Heat losses: As a result of LTDH operation, acceptable annual heat distribution heat losses of 10-15% can be achieved in areas with low-energy houses by cutting the temperature level in half and by doubling the pipeline heat resistances compared to current third generation technology, and by using twin pipes.

Heat supply: Future heat supply will be more diversified and will give opportunities for power system interaction, renewables, and heat recycling from local excess heat resources. The role of heat storages will increase due to the need to make fluctuating renewables more flexible to satisfy customer heat demands.

Independence: The case studies were often demonstration areas with installations supported by research grants. They have a high degree of independence achieved by using renewable energy sources and major heat storages. They represent a new market segment for district heating, which has previously been more associated with large-scale citywide systems in concentrated urban areas.

Heat distribution costs

Both distribution capital cost and distribution heat loss are proportional to the inverse of the heat density. So these two important system parameters depend on a combination of specific heat demands and the concentration of buildings, expressed by the plot ratio. The case studies show that both acceptable distribution capital costs and acceptable distribution heat losses can be achieved for low-energy buildings with low specific heat demands, if these buildings are concentrated. High distribution costs will, however, mean that DH is not viable for low-energy buildings located in areas with low plot ratios.

Table of Content

Executive Summary	4
Table of Content	9
1 Introduction	13
1.1 Terminology	13
1.2 Background and Objective	15
1.3 Content of the Report.....	17
2 The Relevance of Low-Temperature District Heating	19
2.1 The Role of District Heating in the Long Term Perspective	19
2.1.1 Specific District Heating Distribution Cost	19
2.1.2 Strategic planning of DH in the future energy system.....	22
2.1.3 Planning on Energy Saving and Renewable Energy Supply	24
2.2 Advantages of Low-Temperature District Heating	26
2.2.1 LTDH advantages in heat distribution	26
2.2.2 LTDH advantages in heat supply	28
2.2.3 Current barriers for LTDH	30
2.2.4 Conclusions from LTDH advantages.....	31
3 Safe Supply of Domestic Hot Water	33
3.1 Domestic Hot Water Regulation	33
3.2 Legionella Contamination in DHW Installations.....	36
3.3 Legionella Treatment	43
3.4 Low-Temperature Protection Systems	44
3.4.1 Proper Design of in-House DHW Distribution Systems in Small Buildings	44
3.4.2 Low-Temperature Water Treatment in Large Buildings	45
4 Domestic Hot Water Installation	50

Annex X Final Report: Toward 4th Generation District Heating

4.1	Low-Temperature Substations in Single-Family Houses	50
4.1.1	Instantaneous Heat Exchanger Unit (IHEU).....	51
4.2	Low-Temperature District Heating Storage Unit (DHSU).....	52
4.3	Space Heating and Domestic Hot Water Systems in Multi-Storey Buildings	53
5	Low-Temperature District Heating Supply Low-Energy Building.....	56
5.1	Introduction.....	56
5.2	Modelling of SH System.....	57
5.3	Results and Discussion.....	59
6	Low Temperature District Heating in Existing Buildings	64
6.1	Introduction.....	64
6.2	Feasibility of implementing LTDH in existing buildings	64
6.3	Case definition	65
6.4	Analysis results.....	67
6.5	Conclusion.....	69
7	The District Heating Network	71
7.1	Overview.....	71
7.2	Design of Low-Temperature District Heating Networks	72
7.2.1	Network Design in Low Heat Density Areas.....	72
7.2.2	Network Design in Existing Building Areas with Future Reduced Heat Demand	73
7.2.3	Network Design in Extension Areas of Existing Networks	73
7.3	District Heating Pipes for Low-Temperature District Heating.....	73
7.3.1	Pipe Design with Low Heat Losses	74
7.4	Bypass Strategies in Low-Temperature District Heating Systems.....	82
7.5	Low-Temperature Technical Solutions: the “Comfort bathroom”	86
7.5.1	Technical Solutions for CB Concept.....	86

Annex X Final Report: Toward 4th Generation District Heating

7.5.2	Modelling of CB CONCEPT	88
7.5.3	CONCLUSIONS	91
8	Heat Sources	93
8.1	Renewable Energy Based Energy Conversion Systems	93
8.2	Decentralized Heat Generation	95
8.2.1	Micro Heat Pumps for DHW Preparation.....	95
8.2.2	Integration of MTDH and LTDH using Heat Pumps.....	98
9	LTDH Implementation: Case Studies	101
9.1	Overview analysis of case studies	103
9.1.1	Temperature level.....	104
9.1.2	Concentration	105
9.1.3	Heat balance	105
9.1.4	Distribution.....	106
9.1.5	Distribution capital cost.....	108
9.1.6	Summary of the analysis conclusions	108
9.2	Lessons learnt from early projects	108
10	Conclusions.....	112
10.1	LTDH advantages.....	112
10.2	Planning and Technical issues.....	112
10.3	Legionella issue.....	114
10.4	Lessons learnt from early projects	115
10.5	Heat distribution costs.....	116
10.6	Further comments.....	116
	List of Abbreviations	117
	References	119

Annex X Final Report: Toward 4th Generation District Heating

Appendix 1. Low-temperature district heating network for newly-built low-energy single family-houses in Lystrup, Denmark.....	123
Appendix 2. District heating for space heating (SH) and domestic hot water (DHW) demands in multi-family passive houses at Hertings gård in Falkenberg, Sweden.....	137
Appendix 3. District heating as base load heat supply for space heating (SH) and domestic hot water (DHW) demands in new construction multi-family and pair passive houses at Söndrums Kyrkby in the city of Halmstad, Sweden.....	155
Appendix 4. Solar District Heating Network Munich Ackermannbogen - SNAB	176
Appendix 5. Solar District Heating in the Drake Landing Community, Okotoks, Alberta, Canada	183
Appendix 6. Geothermal Low-Temperature District Heating (DH) System in Kirşehir, Turkey.....	193
Appendix 7. Low-temperature district heating network for newly-built Zero Carbon Housing Development - Greenwatt Way – in Slough, United Kingdom.....	199

1 Introduction

The successful implementation of energy-efficient communities is based on the Trias Energetica concept [1], which involves the reduction of energy demand through drastic energy-saving measures, the exploitation of fossil fuels as efficiently and cleanly as possible, and the use of Renewable Energy (RE) sources to meet the remaining energy demand. This represents the roadmap for the transition period, after which the long-term solution for a fully sustainable energy vision must be applied: the total phase-out of fossil-fuels. This is the basic framework this report is based on. The achievement of this ambitious objective in the heating sector will rely on synergy between the extensive implementation of energy conservation policies and the development of technical and political solutions to satisfy the heating demand with RE sources with the best overall socio-economic development. The low-temperature District Heating (LTDH) concept, which will be described in this document, aims at providing a tool that fits such a vision.

1.1 Terminology

In a historical perspective, the new LTDH generation is the 4th generation of the technology, following the steam-based systems (1st generation), the high-temperature water systems (HTDH, $T_{\text{supply}} > 100^{\circ}\text{C}$, 2nd generation), and the medium-temperature water systems (MTDH, $T_{\text{supply}} < 100^{\circ}\text{C}$, 3rd generation).

The use of the term “low-energy DH” is linked to the definition of a community energy supply concept which fits the decreased heat demand in new low-energy buildings and in existing buildings that have undergone an energy retrofit: low-energy supply systems for low-energy demand buildings. Low-energy DH does not necessarily require a low network supply temperature. The introduction of the LTDH concept, as shown in Figure 1.1, however, combines the low energy demand in buildings and low energy supply from the network with the

heat from low-grade heat sources to achieve a long-term sustainable solution.

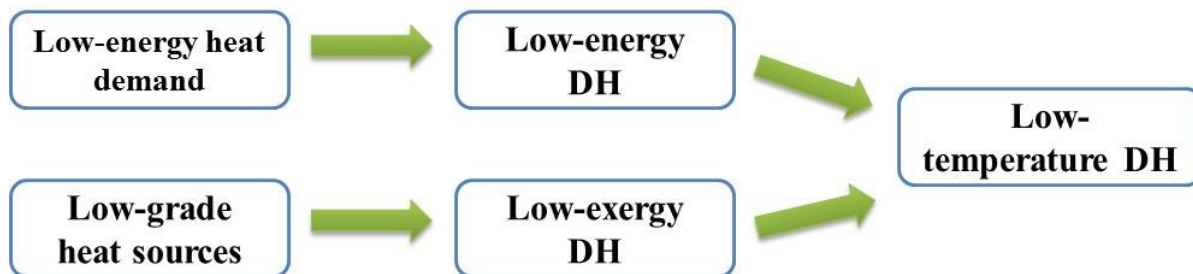

Figure 1.1 The low-temperature district heating concept

We now define the basic terms and expression used in this report:

The basic terms and expressions used in this report are based on EN 253[2], EN 15632 [3] and [4]. They offer the basis for a standardized terminology for DH practice.

District heating system: a heating system which supplies hot water or steam to a building's thermal system from a heat generation system outside the building. The district heating system transmits heat through networks to a number of separate buildings.

Cogeneration: the simultaneous generation in one process of thermal energy and electrical or mechanical energy. Also known as combined heat and power (CHP).

Delivered energy: the energy supplied to a building's technical systems through the system boundaries. It is decided at government level whether or not renewable energy produced on site (solar and wind or other) is treated as part of the delivered energy.

Primary energy: energy that has not been subjected to any conversion or transformation process. Primary energy includes non-renewable energy and renewable energy. If both are taken into account, it is called total primary energy. For a building, it is the energy used to produce the energy delivered to the building. It is calculated from the delivered and exported amounts of energy carriers, using conversion factors.

Surplus heat: heat from industrial and commercial activities that is a by-product (not technically and/or economically feasible to avoid).

Polyurethane rigid foam (PUR): this is produced by the chemical reaction of polyisocyanates with hydroxyl containing compounds in the presence of catalysts, the foaming being assisted by a blowing agent. These foams have a mainly closed cell structure.

Media pipe: the pipe inside which the heat carrier flows, excluding the surrounding insulation. Typical materials are steel, copper or plastic (polyethylene or polybutylene). Note: in EN 253, it is called a "service pipe", but this could cause confusion (see *House Service Connection*)

Casing pipe: the plastic pipe surrounding the insulation and the media pipe(s) and in contact with the ambient material (soil or outdoor air). It protects the insulation and the media pipe from ground water, moisture and mechanical damage.

House Service Connection (alternatively: *House Service Pipe* or *Service Pipe*): the heat distribution pipe, consisting of media pipe(s), insulation and casing pipe leading from the main pipeline to the consumer installation.

Branch pipe: the heat distribution pipe, consisting of media pipe(s), insulation and casing pipe that is connected to a main distribution pipe and serves only a fraction of the number of buildings served by

Annex X Final Report: Toward 4th Generation District Heating

the main distribution pipe. It is a relative definition, since a branch pipe can be a main distribution pipe for another branch pipe. The term can also be used to indicate a service pipe.

Main distribution pipe: the heat distribution pipe, consisting of media pipe(s), insulation and casing pipe, that serves more than one building.

Transmission pipe: the pipe that brings the heat carrier from a major heat source (typically a CHP plant) to a distribution network and is operated at higher pressure and/or temperature than the distribution network.

Single pipe: a single supply or return district heating pipe, consisting of the media pipe, insulation and casing pipe.

Twin pipe: a supply and/or return district heating pipe, consisting of a pair of equal-sized media pipes, embedded in the same insulation and casing pipe.

Double pipe: a supply and/or return district heating pipe, consisting of a pair of different-sized media pipes, embedded in the same insulation and casing pipe.

Bonded system: a system consisting of media pipe(s), insulating material and a casing pipe, which is bonded by the insulating material.

Centre-line deviation: the deviation between the centre line of the media pipe and the centre line of the casing pipe.

Supply temperature [°C]: the temperature of the heat carrier in the media pipe carrying the heat from the heat source to the heat sink.

Return temperature [°C]: the temperature of the heat carrier in the media pipe carrying the heat from the heat sink back to the heat source.

Continuous temperature: the temperature at which the hot water network is designed to operate continuously.

Peak temperature: the highest temperature at which a system is designed to operate occasionally.

Linear heat density [MWh/(m·yr)]: the ratio of the annual heat delivered to the consumers (at the interface building/network) and the trench length of the DH network serving that area.

Effective width [m]: the ratio of the total land area and the trench length of the network.

Plot ratio: the ratio of the total heated floor area and the total land area.

1.2 Background and Objective

One of the major energy development targets in the European Union (EU) is to reduce building energy use and increase the supply of RE. The introduction of the European Energy Performance of Building

Annex X Final Report: Toward 4th Generation District Heating

Directive (EPBD) poses stringent requirements for member countries to reduce their building energy use. The European Council stated in 2011 that the EU objective is to reduce Green House Gas (GHG) emissions by 2050 by 80-95% compared to 1990 and this is to be done internally. The measures necessary to undertake such paradigm shift are in the context of the reductions required according to the Intergovernmental Panel on Climate Change (IPCC) to keep the climate change below 2°C.

Besides climate protection, deep reductions in GHG emissions have the potential to deliver great benefits in the form of savings on fossil fuel imports, increasing energy security, improving air quality and public health, and stimulating technological innovation, sustainable economic growth and job creation. In line with this, the EU Climate Commission roadmap [5] gives ranges for emission reductions for 2030 and 2050 for key sectors (see Figure 1.2). The roadmap states that “*shifting energy consumption towards low carbon electricity (including HPs and storage heaters) and renewable energy (e.g. solar heating, biogas, biomass), also provided through DH systems, would help to protect consumers against rising fossil fuel prices and bring significant health benefits*”. For the first time in European legislation, DH is clearly defined as part of the solution towards a fossil-fuel-free energy sector. For instance, at country level and according to the national energy policy, the building energy use in Denmark will drop to 25% of its current level by the year 2060, while the RE share will increase from 20% to 100% by the year 2050 [6]. These targets demonstrate that the political will to implement the measures to achieve a low-carbon society is present.

This report aims at collecting and discussing successful examples of such implementation in the building heating sector and demonstrating that LTDH is an essential infrastructure for achieving the climate goals with a holistic and integrated approach which takes into consideration its implications for other energy sectors (essentially power and transport), represents good economics and will reduce the socio-economic risks involved.

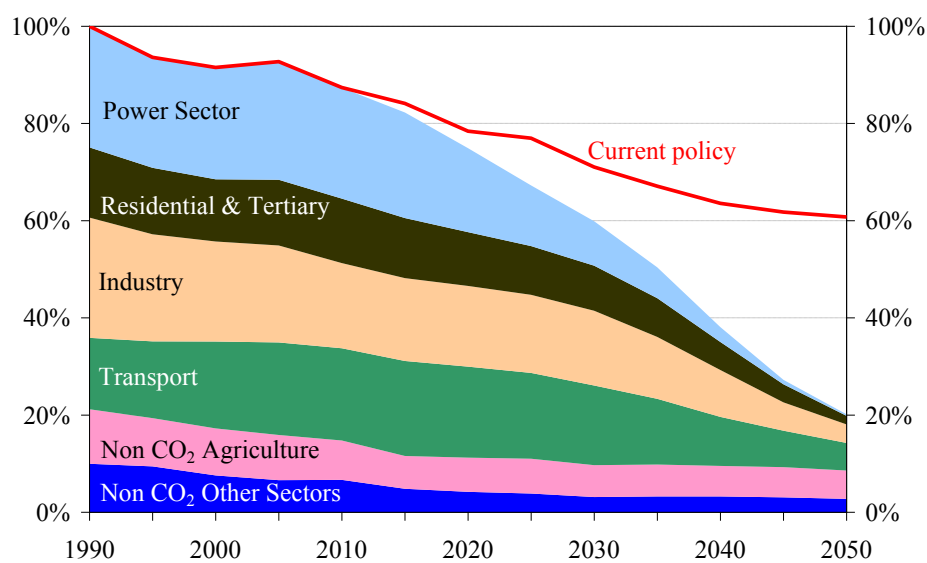

Annex X Final Report: Toward 4th Generation District Heating

Figure 1.2 EU GHG emissions towards an 80% domestic reduction (100% =1990). Source: [1].

The existing technologies require further examination under the new regulations and policies. DH uses hot water or steam as a carrier for transporting energy from remote centralized heat sources to residential, commercial or industrial buildings. It uses low-quality heat sources, often a by-product in the electricity production processes in Combined Heat and Power (CHP) plants. The traditional approach to evaluating a DH system often focuses on the production/supply aspect and only afterwards on the final users. The LTDH concept switches the perspective, starting from end-user thermal comfort and a quality match between energy supply and energy consumption, and aiming to find the best and most economical way to satisfy the heat demand through efficient distribution networks and supply systems based on waste heat and RE. The new concept therefore starts by identifying suitable in-house substations for low-energy-demand buildings at low supply temperature, goes back to design efficient and reliable networks, and finally considers environmentally-friendly heat production units.

The objective of this report is to raise awareness and provide insights that will stimulate the research, development and implementation of LTDH systems. It will help to increase public recognition and assist policy makers and energy planners, both at local and governmental level, in promoting cost-effective and environmentally friendly DH systems, and in planning and realizing long-term sustainable urban area development. To this end, the report addresses the following research issues:

1. What are the main advantages of LTDH?
2. What technology options are available for LTDH, and what are the associated challenges to consider?
3. How can the risk of Legionella be mitigated in LTDH?
4. What lessons can be learned from early LTDH projects?
5. What heat distribution costs are associated with LTDH?

1.3 Content of the Report

In this report, the relevance of the new generation DH concept is emphasized and the related technologies are described. The report consists of the following chapters mainly dealing with the relevance of LTDH, the building installations required, the supply of LTDH to both low-energy buildings and existing buildings, and the optimal design of a DH network and the heat sources.

In chapter 1, the basic terminology used in the report is presented. The background, objective and the structure of the report are described. The five basic research issues are stated.

In chapter 2, the role of DH is discussed with respect to the specific distribution cost, the strategic planning of DH in the overall energy system for a future low-energy-demand society, and the balance between investment for building energy reduction and renewable heat source exploitation.

Annex X Final Report: Toward 4th Generation District Heating

In chapter 3, the DHW regulations that address potential Legionella issues are summarized. Statistical analysis of Legionella contamination in DHW installations is presented. Various types of Legionella treatment method are discussed, and proper design methods to reduce the risk of Legionella in single-family houses and multi-storey buildings are introduced.

In chapter 4, various types of DH substation specifically designed for low-temperature operation for single-family houses and multi-storey buildings are introduced.

In chapter 5, the supply of LTDH for low-energy buildings is discussed through building performance simulation, with emphasis of the consumer thermal comfort and the internal heat gain.

In chapter 6, the potential to supply LTDH for existing buildings is evaluated. Various building renovation strategies are suggested to fit the low-temperature operation.

In chapter 7, the performance of energy-efficient DH networks with pre-insulated flexible twin pipes is examined and the idea of optimal network design and operation is discussed. Strategies to reduce network bypass heat losses are illustrated, and the concept of the Comfort Bathroom is introduced.

In chapter 8, the use of a renewable-energy-based energy conversion system is discussed. The concept of using heat pumps (HPs) for DHW preparation inside residential buildings and for DH network integration of two different temperature levels is discussed.

In chapter 9, the experience from early LTDH projects around the world is drawn upon with regard to efficient low-temperature supply, the integration of low-energy buildings, and renewable energy supply. A short comparative analysis is carried out with existing MTDH systems with respect to performance indicators and heat distribution costs.

In chapter 10, the concepts and technologies for the new generation LTDH system are summarized by providing our answers to the research issues we started with.

2 The Relevance of Low-Temperature District Heating

2.1 The Role of District Heating in the Long Term Perspective

In the EU, strategy for climate stabilization focuses on three targets for 2020: 20% emission reduction, 20% renewable energy supply, and 20% energy efficiency improvement. With regard to the third of these targets, the European heat market for residential and service sector buildings is recognized in the recently adopted Directive on energy efficiency [7] as a key area for the achievement of reduced primary energy supplies. The directive emphasizes that “efficient district heating and cooling” should be a prioritized alternative in towns and conurbations with building-to-land area ratios (plot ratios) of 30% and above. In such regions, explicit heat plans are to be developed to identify heat synergy opportunities, in which, for example, the recovery of excess heat from energy and industry sector activities – distributed in thermal networks to close-by residential and service sector heat demand centres – constitute the active energy efficiency measure. To speed up the process toward 20% energy-efficient improvement, the huge energy-saving potential in the building sector should be exploited. Traditionally, any reduction in heating demand is seen as decreasing DH market share due to the increased distribution cost. The situation is further aggravated by the current financing evaluation method, which favours short-term small investments rather than long-term capital intensive investment in infrastructures like renewable energy systems and DH [8]. It is therefore imperative to investigate the competitiveness of DH in a long-term perspective with significant heating demand reduction.

2.1.1 Specific District Heating Distribution Cost

In comparison with individual heating units, one of the major investments in a DH system is the distribution cost. The total DH distribution cost has four basic components: the distribution capital cost, the annual costs of the network’s heat loss and pressure loss, and the service and maintenance cost. According to [9], the distribution capital cost can be expressed as:

$$C_d = \frac{a \cdot I}{Q_s} = \frac{a \cdot (C_1 + C_2 \cdot d_a)}{\left(\frac{Q_s}{L}\right)} \text{ [€/GJ]} \quad (1)$$

where a is the annuity, derived in accordance with the chosen interest rate and investment lifetime, I is the total network investment cost (€), Q_s is the heat annually sold (GJ/a), C_1 is the construction cost constant (€/m), C_2 is the construction cost coefficient (€/m²), d_a is the average pipe diameter (m), L is the total trench length (m) and Q_s/L is the linear heat density (GJ/m,a).

For an existing network, the linear heat density can be assessed based on the empirical data, and the capital cost can be calculated directly from Eq. 1. However, such empirical data are not available when a new network expansion is planned. To make the method available in a wider range of situations, a general description of the linear heat density is formulated as shown in Eq. 2:

$$\frac{Q_s}{L} = p \cdot \alpha \cdot q \cdot w \left[\frac{GJ}{m,a} \right] \quad (2)$$

Annex X Final Report: Toward 4th Generation District Heating

where $p=P/A_L$, $\alpha=A_B/P$, $q=Q_s/A_B$, $w=A_L/L$ and P is the total population (number), A_L is the total land area (m^2) and A_B is the total building space area (m^2), and w is the effective width, which is expressed as an empirical equation $w=A_L/L=61.8e^{-0.15}$.

The linear heat density is transformed into an expression that considers the population density, specific building space, specific heating demand, and effective width. The new parameter allows the modelling of the distribution capital cost in urban areas before DH is introduced.

This analytical expression for the specific distribution cost has been applied for 83 cities in 4 European countries in [9]. The competitiveness of DH can be illustrated with the distribution capital cost vs. the share of the heating market. As shown in Figure 2.1, in the current situation, the DH market share can increase from 10% to 60% without any significant increase of the marginal distribution cost. Since the estimated average current DH market share in these cities is 21%, this indicates capacity for a threefold DH market expansion in the cities studied. Accordingly, a heat market share of 60-70% is suggested as the indicative threshold market share in European urban areas.

The distribution capital cost increases with decreasing heating demand. To examine the future competitiveness of DH development, we assumed a 20% and a 50% heating demand reduction. According to Figure 2.2, if the threshold for the feasible marginal distribution capital cost remains the same, the DH market share will drop from 60% to 45% in the 20% heating demand reduction scenario, and down to about 10% in the 50% heating demand reduction scenario. To maintain the estimated market share at 60%, higher marginal distribution capital cost would have to be accepted. Such balance can be achieved through higher consumer heating cost (heavy tax on fossil fuel for heating) and lower tax for recycled heat into DH systems (enhancing the use of excess heat).

The main conclusion is that the major cities in Europe are dense enough to maintain the future competitiveness of DH. This conclusion is based on the fact that current heat prices in Europe are about 15-20 €/GJ and the increase in the distribution cost is small compared to the total heat cost level.

Annex X Final Report: Toward 4th Generation District Heating

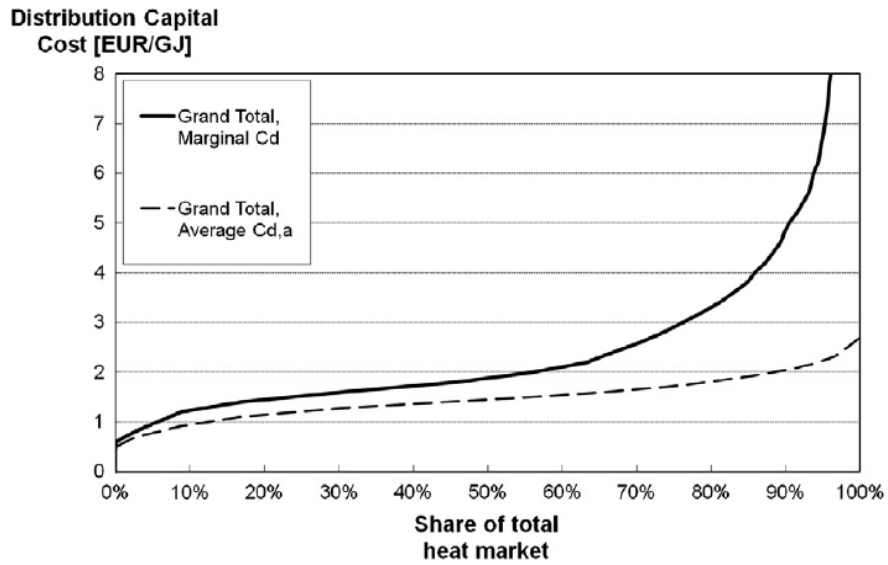

Figure 2.1 Current distribution capital cost levels and the corresponding district heat market shares in the city districts studied. Source: [9]

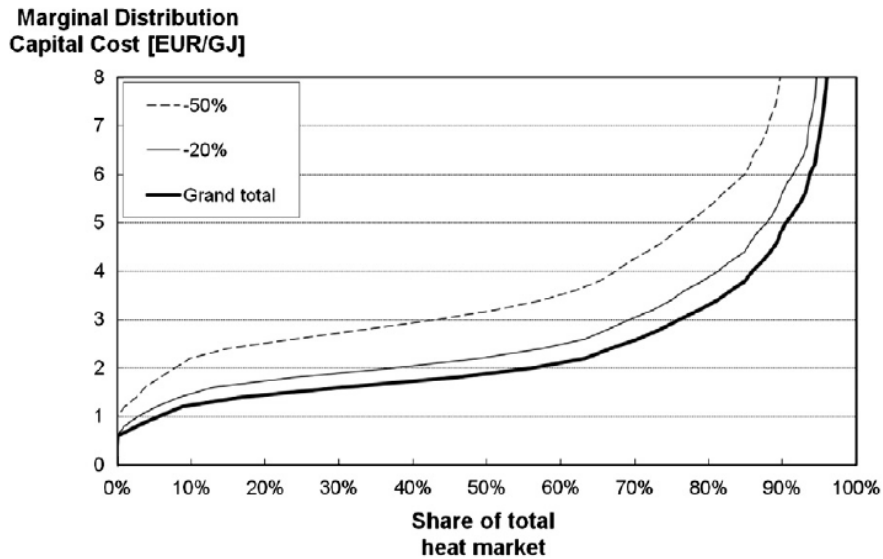

Figure 2.2 Marginal distribution capital cost and the corresponding DH market shares in two different heat demand reduction scenarios. Source: [9].

Annex X Final Report: Toward 4th Generation District Heating

2.1.2 Strategic planning of DH in the future energy system

DH has all the ingredients to incorporate diverse renewable energy sources, improve energy efficiency on both the supply side and the demand side, and integrate other energy supply networks like the electricity grid. It is an essential element for achieving the target of a future 100% renewable energy supply system. To achieve the overall optimal socio-economic effect, an integrated energy planning approach is required to evaluate the entire energy system, including heating and electricity generation technologies, as well as end-user energy savings. Such an approach has been applied to the strategic planning of the future 100% renewable energy supply system in Denmark [10]. At the local level, the integrated energy planning approach was applied to the ‘Energy City’ project of the town of Frederikshavn in Denmark[11]. The aim was to answer what effective early steps can be taken for building energy saving and DH network expansion in a local energy system over a short-term transition period towards the final goal of 100% renewable energy supply.

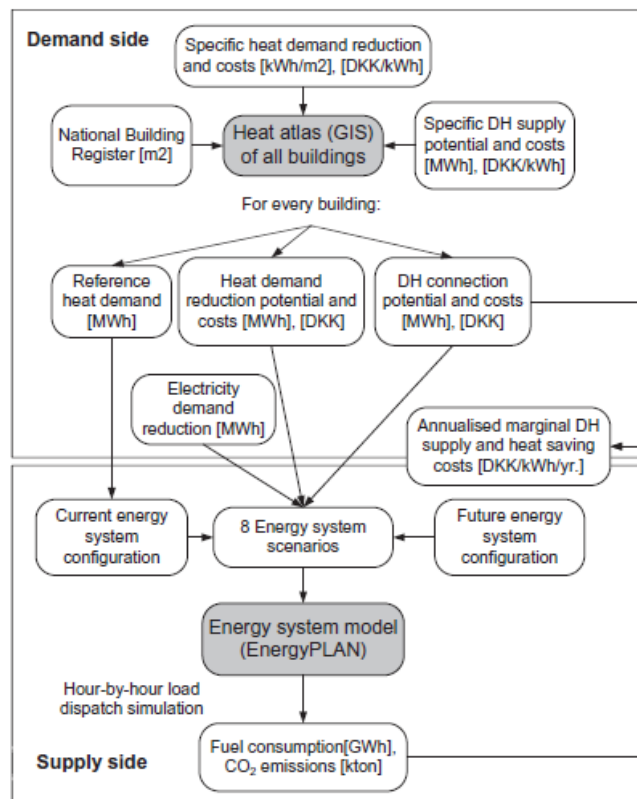

Figure 2.3 Overview of the integrated energy system analysis. Source: [11].

Figure 2.3 shows the schematic of the integrated energy system planning approach. The building stock energy consumption in Frederikshavn was modelled with the tool ‘heat atlas’, which maps building SH and DHW demand in a spatial database. With the heating demand for individual buildings and the GIS information available, the potential for DH network expansion, the building energy

Annex X Final Report: Toward 4th Generation District Heating

reduction, and the associated cost can be estimated. The energy-saving potential was evaluated using empirical data for buildings that are classified with different building types and construction periods. A 20% heating demand reduction and a 15% electricity demand reduction were assumed in the analysis. Based on the assumptions, various energy system scenarios were constructed and evaluated for the entire energy system framework, including both industry and transport using an hour-by-hour dynamic simulation tool, EnergyPLAN.

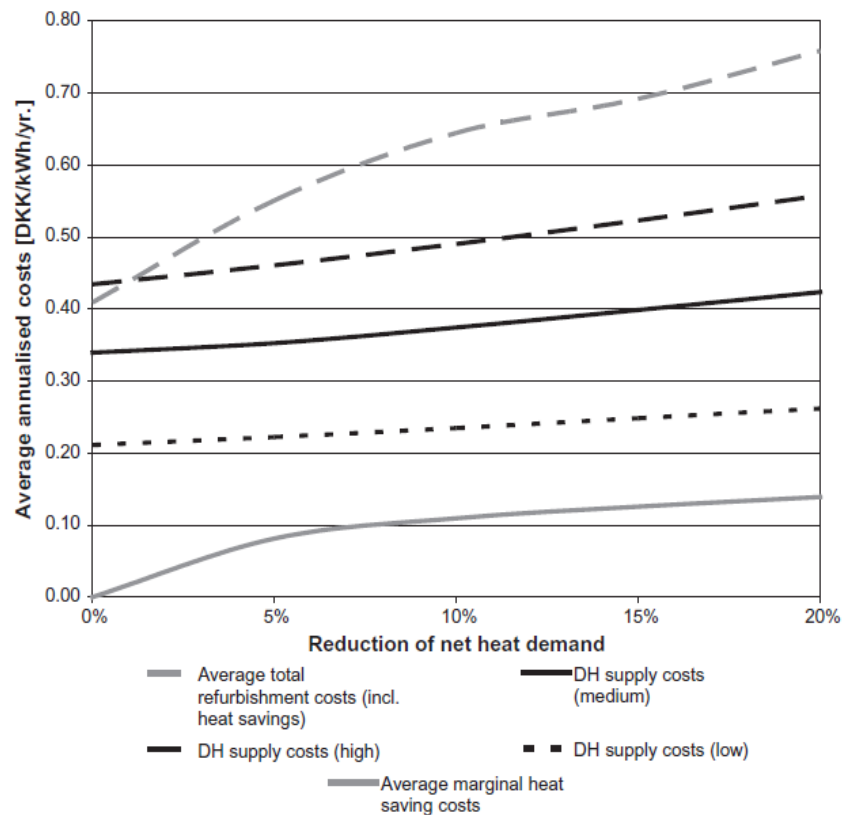

Figure 2.4 Cost curves for heat savings and district heating supply. Source: [11].

The economic feasibility of implementing the end-user energy saving and the DH network expansion was evaluated using an annualized marginal cost based on an interest rate of 3% and a lifetime of 50 years for both heat savings and DH expansion. The study quantified the total and marginal investment cost for building retrofitting. The total cost is the cost for energy-efficient retrofitting, including auxiliary costs, and the marginal cost refers only to the extra cost generated due to energy-efficient retrofitting. The DH supply cost is a combination of DH connection costs, natural gas prices and CO₂ costs.

Figure 2.4 shows the comparison between the DH supply cost and the building heat saving cost with a building heating demand reduction from 0% to 20%. It indicates that under all the 3 scenarios made for different fuel and emission costs, the DH supply cost is higher than the average marginal heat saving cost. Further study shows that the building heating demand must be reduced to 50% to

Annex X Final Report: Toward 4th Generation District Heating

increase the average marginal heat saving cost to the same level as the lowest DH supply cost. This indicates that it is a socio-economically feasible approach to implement substantial building energy-saving measures along with the expansion of DH network.

2.1.3 Planning on Energy Saving and Renewable Energy Supply

The EU long-term decarbonization target is to cut greenhouse gas emissions to 80-95% below the 1990 level by the year 2050. To realize this low-carbon future, strong support for renewable energy is required which would result in a renewable energy share up to 75% in the final energy consumption [12]. Special attention should be given to renewable energy investment due to its large share in the total energy supply and its inherently capital-intensive characteristics. With regard to DH systems, one argument is that the planning of renewable heat generation technologies and their capacities should come after the building energy reduction, so that the energy production plants can be designed with smaller installed capacity and thus save on capital investment and improve their partial-load operation.

A case study has been carried out for the city of Copenhagen in Denmark to prioritize investment for building energy reduction and various renewable energy technologies during the transition from the fossil fuel to 100% renewable energy [13]. The study assumed that coal will be phased out by 2025, in accordance with the city plan. The major renewable sources available are biomass, geothermal and waste incineration. Due to the scarcity of biomass sources in Denmark and the priority put on its use for transport, biomass will only be available until 2040, after which it will all go to the transport sector. On these assumptions, a simple and general engineering economic analysis was carried out based on three different future energy planning scenarios:

- Reference scenario: No building renovation but only natural replacement of existing buildings with new buildings. Each new building corresponds to 50% energy consumption of the existing building replaced. Assuming a 1% annual replacement rate, the annual heating demand reduction rate is 0.5%.
- Scenario 1: Deep energy renovation is carried out from 2030 to 2070 and the heat demand decreases by 65%.
- Scenario 2: Deep energy renovation is carried out from today until 2040 and the heat demand decreases by 65%.

The costs for the reference scenario are based solely on the heating plant investment whereas the costs for Scenarios 1 and 2 also include the costs for building energy renovation. The real interest rate is not considered in the study, which results in lower cost estimations than likely in real life.

Annex X Final Report: Toward 4th Generation District Heating

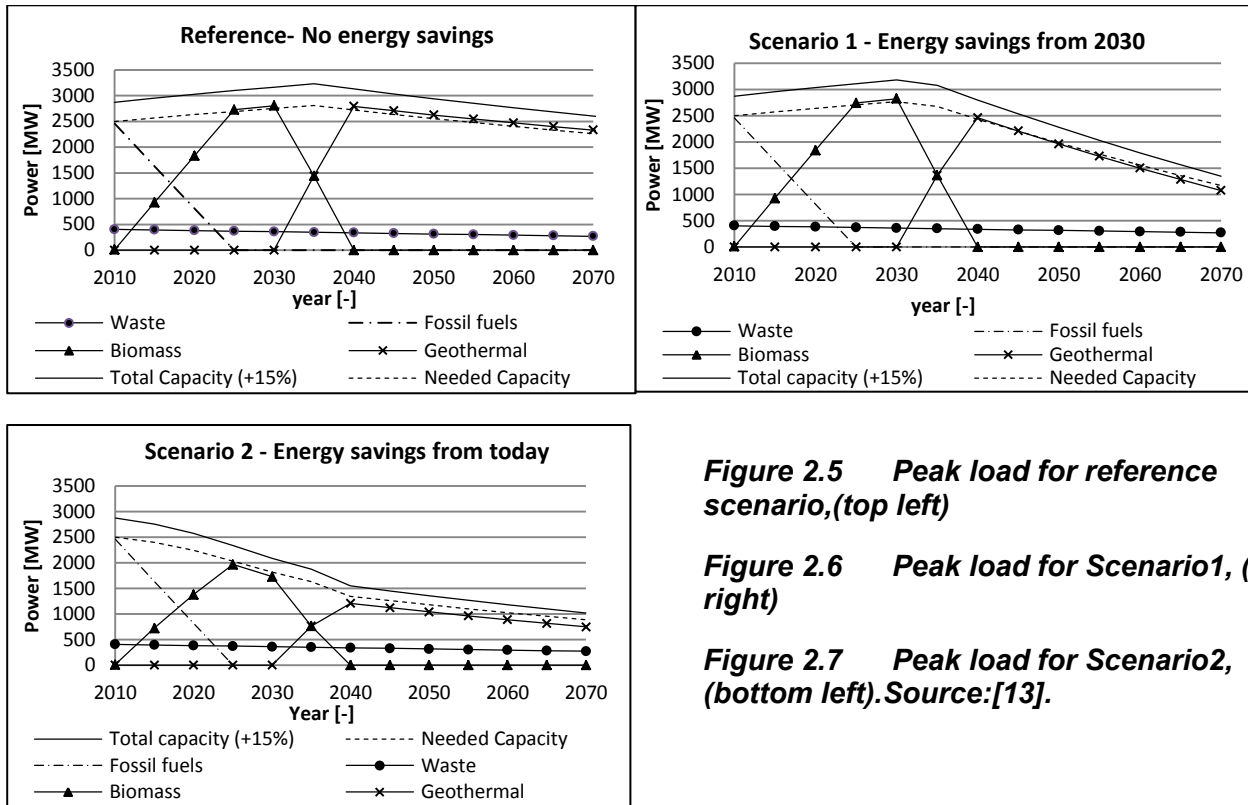

Figure 2.5 Peak load for reference scenario, (top left)

Figure 2.6 Peak load for Scenario1, (top right)

Figure 2.7 Peak load for Scenario2, (bottom left). Source: [13].

The economic analysis results are presented in Figure 2.5 to Figure 2.7, representing the reference case, Scenario 1 and Scenario 2, respectively. In the reference case, the heat demand increases until 2035, due to the conversion of the natural gas area to DH, and then decreases due to energy savings of 0.5% per year for new buildings. The priority for resource utilization follows the sequence: waste for incineration, geothermal, biomass and fossil fuel. The consumption of fossil fuel is gradually decreased down to zero by the year 2025. Due to relatively stabilized waste incineration utilization, the heating supply reduction due to the decrease of fossil fuel is replaced by biomass before 2030. After 2030, the energy supply from biomass is gradually reduced and will be phased out by 2040. The installed capacity from geothermal starts from 2030 and reaches its peak at 2040 with total capacity 2800 MW, and then decreases by 13% until 2070.

In Scenario 1, the heating demand decreases by 65% from 2030 to 2070. Geothermal plants are established from 2030 to fulfil the heating demand vacuum caused by the gradual phasing out of biomass between 2030 and 2040. The installed geothermal plant capacity starts increase from 2030 and reaches its peak at 2500 MW in 2040, slightly lower than in the reference case, and then decreases by 60% by 2070.

In Scenario 2, the heating demand decreases 65% from today to 2040. Due to significant heat demand reduction, the required geothermal capacity reaches its peak in 2040 at 1200 MW, which

Annex X Final Report: Toward 4th Generation District Heating

corresponds to a 60% reduction compared with the reference case and a 45% reduction compared with Scenario 1.

The study shows that reducing the heat demand results in smaller peak loads, thus saving capital investment and realizing more stable renewable energy plant operation. It is in general a cost-effective solution to achieve substantial building energy reduction before investing in new renewable energy generation capacities for the long-term planning of the DH system.

2.2 Advantages of Low-Temperature District Heating

DH traditionally benefits from a combination of economies of scope and economies of scale. The economies of scope come from the synergies with heat recycling from thermal power generation, waste-to-energy plants, and industrial heat recovery. The economies of scale are associated with the mass production of heat from central heating plants and heat distribution in large pipes.

The significant reduction in building energy use and the need for a wider exploitation of waste heat and RE, however, mean that current DH technologies become barriers to any further increase in the market share [14]. The concepts for designing and operating DH systems need to be re-examined under the new energy regulations and the development trends in the energy sector, if the economic competitiveness of DH is to be sustained and long-term sustainable development realized. This is the main driver for introducing the concept of 4th generation DH systems. When building heating demand drops to one-quarter of the current level, the relative heat loss along the current DH network becomes unacceptably high. The immediate and effective solution is to reduce the temperature level in the network. Based on the studies [15], [16], and [17], and with a properly designed in-house substation system, a network supply temperature of 50-55°C and a return temperature of 25-30°C can meet end-user Space Heating (SH) and Domestic Hot Water (DHW) demands in central and north European climates. Examples of such applications in real cases are reported in the Appendix for energy-efficient building areas. Its possible application in existing buildings is discussed in Chapter 6 of the report.

The concept includes the option of increasing the supply temperature in peak load periods during the heating season to limit the dimensions of the distribution pipelines. The temperature level during these periods depends on the climate, the availability of energy sources at higher temperature, and the overall economics, and thus depends on the case considered. A typical supply temperature for peak load periods in Scandinavian countries could be 65-75°C.

The low supply and return temperatures in the distribution network constitute the most distinctive feature of the new generation LTDH systems.

2.2.1 LTDH advantages in heat distribution

The main advantages of the reduced network temperature level in heat distribution are:

Reduced network heat loss

Annex X Final Report: Toward 4th Generation District Heating

Decreasing the temperature level of the network effectively reduces heat loss along the pipeline. The heat loss can be further reduced with optimized network design methods and pre-insulated flexible twin pipes. This lower heat loss also means lower supply temperature drops in the flow direction than with MTDH.

Improved quality match between heat supply and heat demand

The future building heating demands will not require high temperatures. The reduced network supply temperature better matches the building heating demand and reduces losses from the energy quality (exergy) point of view [18]. Most current heating systems were designed for direct use of fossil fuels, which have no problem generating higher temperatures.

Reduced pipeline thermal stress

With the lower supply temperature, there will be less variation in the supply temperature along the pipeline. This reduces the risk of pipe leakages due to thermal stress and the corresponding maintenance costs are reduced as well.

Other pipe materials possible

Lower network temperatures make it possible to use plastic pipes in distribution areas with low pressures. In MTDH, metals such as steel and copper are used to handle current combinations of temperatures and pressures.

Reduced boiling risk

The reduced supply temperatures will also reduce the risk of water boiling in the network. This means lower risk of two-phase-flow in pumps and fast moving water walls, when pressurized steam escapes quickly through small pipe holes.

Reduced risk for scalding

Scalding of human skin is a potential risk in major water leakages when supply temperatures are higher than 65°C. The lower supply temperatures of LTDH would eliminate that risk.

Annex X Final Report: Toward 4th Generation District Heating

2.2.2 LTDH advantages in heat supply

The main advantages of the reduced network temperature level in heat supply are:

Improved power-to-heat ratio in steam CHP plants

The profit from a CHP plant greatly depends on the amount of power being generated. This is particularly relevant in a liberalized electricity market. Low network supply and return temperatures allow more power to be extracted from steam expansion processes at the same heat load.

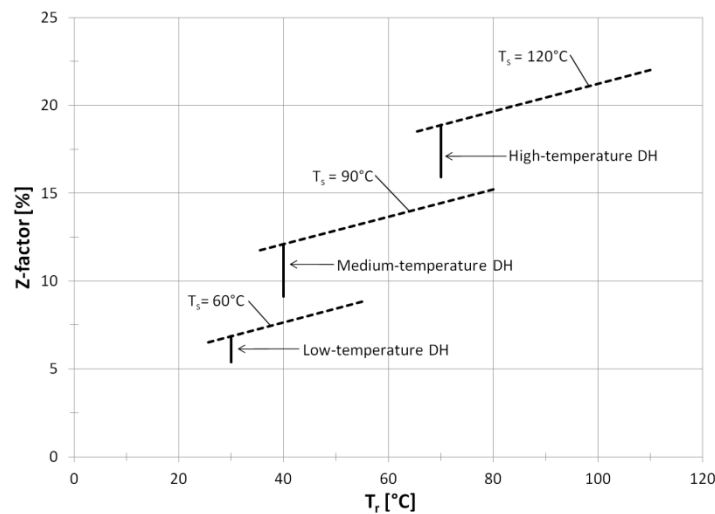

Figure 2.8 Z-factor in an extraction-condensing turbine for CHP as function of the DH operating temperatures. Source: [4].

The cost of heat produced in an extraction-condensing turbine is determined by the resulting reduction in electricity production.

The reduction of the electricity output can be defined by the z-factor:

$$z = E_{\text{electricity, loss}} / E_{\text{heat, production}} \quad (3)$$

Figure 2.8 shows the z-factor calculated for the range of temperatures suitable for high-, medium- or low-temperature DH [4]. The vertical segments refer to the z-factor values that correspond to supply temperatures equal or lower than the design supply temperature and to the following return temperatures: 70°C (high-temperature DH), 40°C (medium-temperature DH), 30°C (low-temperature DH). It can be seen how energy efficiency benefits from lower operating temperatures and that the z-factor is more sensitive to the supply temperature than to the return temperature. The z-factor is the inverted value of the coefficient of performance (COP) defined for heat pumps. So another conclusion

Annex X Final Report: Toward 4th Generation District Heating

from Figure 2.8 is that the COP for steam CHP plants in LTDH networks is much higher than the COP for commercial individual heat pumps, which means a higher utilization of the primary energy supply.

Higher heat utilization from flue gas condensation

The low return temperature makes direct flue gas condensation from combustion flue gases possible. This is particularly relevant for biomass and waste-based CHP plants, due to the high moisture content in these fuels. In this way, the flue gas condensation recycles some of the difference between the upper and lower heating values in the fuels. Some biomass plants in Sweden have flue gas temperatures of 30°C. Greater heat recovery from gas engines through condensing heat recovery on exhaust gases, and the recovery of some or all of the intercooler heat that is otherwise dispersed, can increase the heat recovery by up to 25%.

Higher coefficient of performances in heat pumps

Lower network temperatures make heat pumps more competitive, since both pressure and temperature can be lower in the heat pump condenser. This situation will require less electricity for the compressor, giving a higher coefficient of performance.

Higher utilization of low temperature industrial excess heat

The low network supply temperature allows further exploitation of low-exergy excess heat, either from industrial processes or by heat recovery from cooling processes.

Increased utilization of geothermal heat

Thanks to the low operating temperatures, it is possible to integrate additional geothermal sources and make them competitive in relation to in-building heat generation technologies. Fluid temperatures below 60°C make geothermal plants (shallow geothermal coupled to HPs or deep geothermal) more advantageous because they will be able to satisfy the base load demand. Very large geothermal resources in Europe have temperatures between 40 and 80°C.

Higher conversion efficiencies in central solar collector fields

Lower network temperatures increase the conversion efficiency from solar energy to solar heat in solar thermal collectors – both roof collectors and large-scale solar thermal fields (see Figure 2.9).

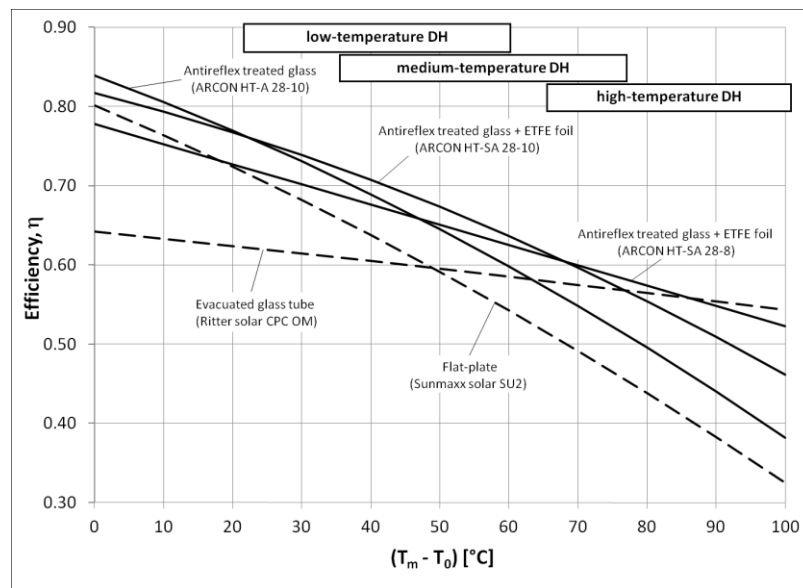

Figure 2.9 Efficiency of solar collectors as a function of the difference between the average T of the fluid in the collector, T_m , and the ambient temperature, T_0 ($G=1000\text{W}/\text{m}^2$).
 — Large-scale solar thermal collector, source: [4][19]
 ---- Small-scale solar thermal collector, source: [20].

Reduced heat loss in thermal storage units

Thermal storage units in a DH system range from large seasonal storage tanks to small-scale tanks in the consumers' installation. Lower network temperatures will reduce heat losses from thermal storage units if they operate within range of the supply and return temperatures.

Greater utilization of thermal storage units

If higher temperatures are available in heat supply, lower return temperatures will increase the capacity in water-based heat storages in rock caverns and water tanks.

2.2.3 Current barriers for LTDH

Currently, the main barriers to lowering the network temperatures in existing networks are:

Demand Side Limitations (e.g. Radiator sizes)

Current heat demands and current radiator sizes require rather high radiator temperatures in most customer radiator systems. Radiator sizes have traditionally been chosen with rather high design temperatures, since it has been easy to provide these temperatures with the fossil fuels that dominate the heat supply in most countries.

Annex X Final Report: Toward 4th Generation District Heating

If these high radiator temperatures are generated by DH, the network temperatures must be higher so that the substations can provide the requested radiator temperatures.

High return temperatures at the customer side (e.g. malfunction of the hydraulic circuits at the SH and DHW side) are a limitation also. They reduce the available temperature difference for the DH network. At the one hand side that means hydraulic limitation and high auxiliary energy for the network pumps, often higher than the specific value in 3rd Generation systems. At the other hand side higher heat losses are the consequence because of higher average network temperatures.

Legionella issue

Legionella growth is counteracted and safeguarded against by national regulations requiring high hot water temperatures. So these regulations with respect to the human health have become barriers for lower network temperatures in DH systems.

Substation faults

Various faults in substations can result in higher return temperatures than expected in the design phase. Such faults create overconsumption of the circulated water and can occur in heat exchangers, control chains, and system design. They could be due to mistakes made in the design phase, the commissioning or operation, or be due to malfunctioning components or set-point errors. These faults must be quickly identified by effective monitoring and eliminated in future LTDH to maintain a low temperature level in the networks.

Short-circuit flows in networks

Short-circuit flows are direct flows between the supply and return pipes without passing any heat exchanger in a substation. These flows can be both intentional and unintentional. Intentional short-circuit flows are used as bypasses in heat-sparse areas with high heat losses in order to maintain a minimum supply temperature, especially in periods of low heat demand during summers. They are also used in distribution and branch pipes currently lacking customers in order to avoid freezing during winters. These short-circuit flows should be controlled by thermostatic valves that only open occasionally to maintain the minimum supply temperature. Sometimes, these thermostatic valves are missing, resulting in high volume short-circuit flows throughout the entire year. Unintentional short-circuit flows can be remnants from the construction phase, e.g. flushing loops when the pipes were filled with water, or they can be pure connection mistakes between the supply and return lines.

2.2.4 Conclusions from LTDH advantages

The focus on low network temperature aims not only to bring about a new (more economical) design concept for the next generation of DH systems, but also to provide local energy planners and DH utilities with a solution for further increasing the market share in the current situation. DH is well developed in Scandinavian countries and could potentially cover 80-90% of the heating demand in

Annex X Final Report: Toward 4th Generation District Heating

specific areas. Further market penetration means penetration of areas that are currently supplied through individual heat generation units like natural gas furnaces and oil boilers but are in the periphery of urban districts supplied by DH. The linear heat density in such areas is normally quite low (typically between 0.2 and 2 MWh/(m·a)) and the DH heat loss would exceed the energy savings from central heat supply if current DH technologies were deployed. Consumers in such areas may prefer individual heat generation units for economic or psychological reasons. Furthermore, the DH market penetration is encumbered by the fact there is no obligation to connect to an available DH net in low-energy density regions. Under these circumstances, LTDH might be one of the most appropriate candidates to help remove these barriers. The idea of designing a new generation of DH is to develop a flexible, smart and secure energy supply, transmission and distribution system with effective integration of energy-efficient buildings and low-temperature energy sources, such as some renewable energy sources. The reduction of DH distribution temperatures requires the development of DHW and SH systems that can meet the low-temperature requirements and use the limited available temperature difference between the supply and the return temperature. An integrated design approach must be implemented during the design process with overall technical, economic and environmental assessment of the buildings, the DH network and energy supply systems based on RE, waste-to-heat and excess heat.

The main conclusion from this LTDH advantage analysis is that LTDH systems provide more diversified heat supply options, greater heat supply efficiency, and greater heat distribution efficiency.

3 Safe Supply of Domestic Hot Water

3.1 Domestic Hot Water Regulation

The LTDH concept aims at reducing the supply temperature, while still fulfilling comfort requirements for DHW and SH. First, SH systems can be designed and operated at temperatures that are only slightly above the indoor operative temperature. Secondly, with regard to DHW heating, the minimum DHW temperature depends on the requirements for health (Legionella risk) and customer comfort. For instance, in Denmark, the required DHW temperature from fixtures in the kitchen is 45°C, and 40°C for other tapping points. Other countries may have different, yet similar, requirements (see **Fejl! Henvisningskilde ikke fundet.**). Due to their large-volume DHW storage tanks, vertical risers in multi-floor buildings, T-pipe connections, large-diameter DHW pipes or DHW recirculation pipelines, traditional DHW systems have to ensure that the return temperature from the DHW recirculation is much higher than 50°C in order to prevent the risk of Legionella. As a consequence, the current DH minimum supply temperature is above 60°C.

Table 3.1 Overview of the DHW regulations/code of practice in the countries participating in the IEA-DHC Agreement

Country	Description
Germany	<p><i>Reference:</i> Guideline DVGW Code of Practice W551</p> <p>A distinction is made between:</p> <ul style="list-style-type: none"> - small systems, for instance one- or two-family houses with reduced requirements due to low Legionella risk (possible operating temperature < 60°C, but not lower than 50 °C). Small systems have either an instantaneous DHW HE unit or DHW storage units with a volume < 400 L, and the DHW distribution pipe in each building has a water content of less than 3 L between the DHW unit outlet and the tapping point. - large systems, for instance multi-family residential buildings, nursing homes for the elderly, hospitals, hotels. Large systems are all installations that do not fall under the definition of small systems. It must be ensured that the water content in the system has a homogeneous temperature (maximum temperature drop: 5°C). Drinking water systems must be designed so that the total water volume of the preheating stages can be heated up to 60°C once a day. In the case of instantaneous DHW HE units, it must be possible to maintain a temperature of 60°C at the DHW outlet from the unit. Taking into account the requirement about the temperature homogeneity of the water in the DHW distribution pipes, the temperature must never fall below 55°C. <p>In large systems, circulation systems or self-regulating parallel heating systems must be installed. They must also be dimensioned, so that the DHW temperature does not fall more than 5°C below the outlet temperature from the DHW unit. Timers for circulation pumps and self-regulating parallel heating systems must be set in such a way that the DHW circulation is not interrupted for more than 8 h/day. Additional confirmations for the correct hygienic status</p>

Annex X Final Report: Toward 4th Generation District Heating

are necessary in case of using this interruption option.

France

Reference: Arrêté du 23 juin 1978 article 36 – Installations for the distribution of domestic hot water” and its modification (“Arrêté du 30 novembre 2005”).

The DHW regulations in France are based on the “*Arrêté du 23 juin 1978 article 36 – Installations for the distribution of domestic hot water*” and its modification (“Arrêté du 30 novembre 2005”). The DHW temperature should not exceed 50°C at the tap points in devices for personal hygiene or 60°C at other tap points (such as in the kitchen); for industrial or special uses, the temperature can be up to 90°C, but special signs must warn potential users.

In collective DHW distribution pipelines (such as multi-family buildings), the temperature must be higher than 50°C. The water supplied by DHW storage devices must meet one of the following requirements:

- be permanently at a temperature higher than 55°C at the device outlet;
- during the 24 hours before the DHW use, its temperature must be raised to either at least 60°C for at least 60 minutes, or to at least 65°C for at least 4 minutes or to at least 70°C for at least 2 minutes.

These requirements apply in either of the two following cases:

- the water volume in DHW storage tanks is greater than 400 L;
- the water volume in the distribution pipe between the outlet of the DHW production device and each tapping point is greater than 3 L.

Denmark

Reference: Danish Standard for DHW installation (DS 439)

The DHW regulations do not differentiate between small and large systems, as in the German DVGW Guidelines W551. DS 439 states that the DHW system should be designed to be capable of preparing DHW at 60°C and maintain at least 50°C in all the distribution lines (45°C during peak load). The Danish guidelines result in stricter rules than the German ones for “small systems” and in less strict rules for “large systems”. There are no regulations in Denmark dealing directly with Legionella prevention and control. Some legislation has indirect influence, e.g. legislation on swimming pools. The overarching legislation is a transposition of the EU Biological Agents Directive.

Sweden

Reference: Information provided from the expert group member from Sweden

Under current rules, a DHW temperature of no less than 50°C must be reached at the DHW tapping points and no higher than 60°C due to the risk of scalding. In addition, the circulation pipes for DHW must be designed in such a way that the temperature of the circulating DHW does not fall below 50°C in any part of the installation. The DHW temperature in the heaters/storage tanks must not be below 60°C. Furthermore, heating of the cold water pipes in the installation must be avoided.

Annex X Final Report: Toward 4th Generation District Heating

Norway	<i>Reference:</i> Prevention of Legionella – guidelines, 3. edition, chapter 7. National Institute of Public Health (in Norwegian)
	The DHW system must be designed so that the temperature at any tap point in the system must reach at least 60°C within one minute after opening a tap. The return temperature in DHW systems with continuous water circulation must not be less than 60°C. The whole DHW system must be flushed regularly with water at a temperature of at least 70°C. The temperature in DHW accumulators must be at least 70°C. The same conditions must be fulfilled for DHW connected to district heating systems.
Finland	<i>Reference:</i> Building code, part D1, Water supply and drains installations for buildings, Ministry of Environment 2007(2010). Source of requirement: Residential health guideline, Ministry of Social Affairs and Health.
	DHW must be $\geq 55^{\circ}\text{C}$ throughout the DHW system except for close to the tap points (10 sec recovery time allowed). Max. DHW temperature is 65°C .
	For DH this means (Finnish Energy Industries recommendation/“standard” → a DH company requirement) that customer substations have to be designed so that DHW from the HE (in Finland always instantaneous HE) must be $\geq 58^{\circ}\text{C}$ with dimensioned DHW flow (small house $\geq 0.3 \text{ dm}^3/\text{s}$, 60 kW).
The Netherlands	<i>Reference:</i> In February 2002, a transition act to prevent the spread of Legionella was replaced by the ‘Modelbeheersplan Legionellapreventie in Leidingwater Distributie VROM (The Netherlands Ministry of Housing) Nr.16827’. The law requires that the hot water system should be maintained at least 60°C . On the other hand, efforts have to be made to avoid pipes with stagnant water to prevent the growth of Legionella.
The United Kingdom	<i>Reference:</i> Approved Code of Practice and Guidance L8. To reduce the risk of colonization of a water system the storage temperature, controlled from a thermostat, should be as close to 60°C as practicable without being any lower and the calorifier should be capable of maintaining a supply temperature of 60°C under normal operating conditions, including times of peak demand. Distribution pipework design should enable hot water to reach all outlets within a few seconds of turning on the tap: the minimum temperature required is 50°C , but in most cases it will be at $55\text{--}60^{\circ}\text{C}$; the maximum flush time to achieve this is 1 minute, but in most cases the time required will be considerably less. The water temperatures and delivery times recommended in the HSE’s Approved Code of Practice L8 might not be achievable where hot water is provided by instantaneous water heaters or combination boilers. However, the Legionella risk is considered to be acceptable provided that all of the following conditions, given in BS 8558:2011, are met: <ul style="list-style-type: none">• the cold supply is directly from the supply pipe and under mains pressure;• the volume of cold water pipework subject to heat gain (i.e. generally above ground pipework) is less than 1.0 L; and• the volume of pipework from each hot water outlet to the heat source is less than 1.5 L.

Annex X Final Report: Toward 4th Generation District Heating

Canada *Reference:* Information provided from the expert group member from Canada

In Canada, the most commonly used domestic hot water heating systems for residential applications are storage type heaters, with either electric immersion heating elements or a natural gas or other fuel-fired combustion heating input. The National Plumbing Code of Canada (2010) indicates that electric storage water heaters must be supplied to the end-user such that thermostat controls are factory pre-set to 60°C.

The common recommendation is that storage tank temperatures should not be set below 55°C to minimize the risk of Legionella growth.

In the province of Ontario, the Ontario Building Code (2007) further specifies that the maximum hot water temperature supplied to fixtures in residential applications must not exceed 49°C, achieved either by installing an anti-scald mixing valve on the discharge side of the storage tank, or by installing mixing valves on supplies to individual fixtures. Dishwashers and clothes washers are exempt from the 49°C maximum.

Commercial building systems generally follow the recommended operating conditions outlined in ASHRAE Guideline 12-2000.

USA *Reference:* Information provided from the expert group member from USA

The most common DHW supply is a system with storage. The average DHW consumption is approximately 5000 kWh per dwelling per year. That is nearly twice the energy consumption in Europe. The reason is that hot water is used not only for cleaning and personal hygiene, but also for other areas such as dishwashers. There is no federal law against the risk of Legionella, but a recommendation from the U.S. government giving energy regulations for apartments states that the temperature of the water in the boiler must be at least 48°C.

3.2 Legionella Contamination in DHW Installations

Legionella is a group of gram-negative bacteria that growth in water and humid environment. Potential factors which may influence the growth of Legionella include water temperature, the dimensions and age of the hot water system, its hydraulic structure, and materials of construction, stagnation of the water inside the pipework, scaling and particle in the hot water itself, and the presence of commensal microbial flora (biofilm) [21]. Among these, the water temperature has a critical impact on Legionella growth with the optimal proliferation temperature ranges between 30-45°C. To identify the safety margin to supply DHW at low temperature, a statistical research project was carried out in Germany to investigate whether it would be possible to reduce the DHW temperature by 5°C in various types of building and technical installation [22].

The basis for the investigation was a dataset of 75,107 water samples taken from six organizations and institutions in the years of 1988–2011. A project database was established covering 5,337 buildings and a total of 5,742 DHW generation systems. Four categories of contamination were

Annex X Final Report: Toward 4th Generation District Heating

specified on the basis of the place(s) at which the samples were taken, as shown in Table 3.2[23]. The categorization requires samples taken at least at all the points defined in the table.

Table 3.2 Categories of contamination region and minimum amount of sample points within a series of samples

No.	Category	Minimum number of sample points
1	Contamination from the public water supply	Potable water (cold) at the building entry point
2	Central systemic contamination of the drinking water system	Potable water (cold) at the entry to the DHW generator; DHW at the outlet of the DHW generator
3	Partly central contamination	As in Category 2 plus a representative number of DHW-ascending pipes, the respective horizontal distribution pipe lines, and the corresponding sections of circulation pipe lines; Entry point of the circulation to the DHW generator
4	Peripheral contamination	As in Categories 2 and 3 plus a representative number of tapping points for potable water (cold and hot)

PWC – Potable water (cold); DHW – domestic hot water

The statistical analysis of correlations between technical parameters and relevant temperatures of the samples focused on the allocation of laboratory test results with regard to the parameter *Legionella* spp¹. into the following three groups:

NADNo abnormality detected

Numbers resp. percentage of samples with *Legionella* spp. ≤ 2 CFU/100 ml

K2-99Measures not required

Numbers resp. percentage of samples with 2 CFU/100 ml $< Legionella$ spp. < 100 CFU/100 ml

K100Measures required according to DVGW W 551

Numbers of samples resp. percentage with *Legionella* spp. ≥ 100 CFU/100 ml

The positive finding was that, irrespective of the sampling temperature, 74% of all samples showed no *Legionella* spp. detected. One of the main reasons for this may be the short dwell time of the potable water² in the drinking water system, which limits the optimal growth conditions for Legionella.

The average K-100 indication for all datasets was 14.2%. According to the classification in Table 3.2, the distribution of Legionella can be described with the following categories: 1. Contamination from the

¹Spp.= species; *Legionella* spp. means, that the used method detects only the total number of culturable bacterias of the species Legionella. However, there is no information on whether it is a *Legionella pneumophila* or not.

²Dwell time= timefor which a volume element of potable water isinside the installation from the building entry point to the outlet at the taping. Potable water can be PWC, DHW or mixed water

Annex X Final Report: Toward 4th Generation District Heating

public water supply, 2. Central systemic contamination of the drinking water system (Figure 3.1), 3. Partly central contamination (Figure 3.1), and 4. Peripheral contamination.

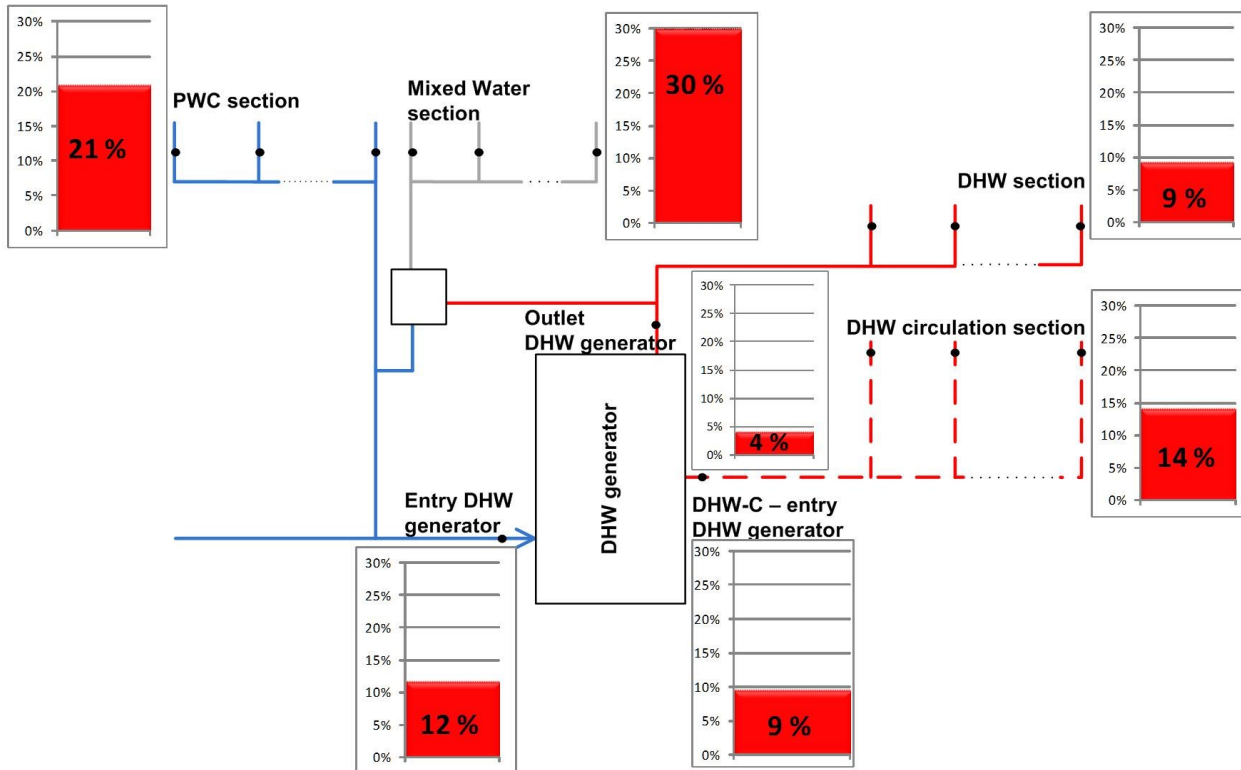

Figure 3.1 Summary of central systemic and partly central contamination (K100-indications). PWC – potable water (cold); DHW – domestic hot water³. Source: [22].

Blue lines: PWC – potable water (cold); red lines: DHW – domestic hot water;
 Grey Lines: Mixed water (water behind a mixing point of PWC and DHW)

1. Contamination from public water supply

For PWC at the building entry point (the switchover from the public water supply to the drinking water installation) 742 datasets taken from 191 hot water generation systems. The percentage of K100-indications that can be verified using current test methods is 0.4%, which is very low, as expected.

2. Central systemic contamination of the drinking water system

³Simplified overview without scale! The distance between the marked points (for instance the DHW circulation section and the DHW-C – entry DHW generator) could be from only a few meters up to 100 m and more. The values for legionella spp. could change significantly between such points, because of different volume flows and temperatures in the sections and so on.

Annex X Final Report: Toward 4th Generation District Heating

The evaluation requires at least knowledge of legionella indicated at the outlet of the domestic hot water generator (DHW generator) as well as ideally at the entry's of the DHW generator.

In total 4,033 data sets related to the *outlet of the DHW generator* (4.2 % of these data show a K100-indication, see Figure 3.1) and 168 data related to the *entry of the potable water (cold) to the DHW generator* are available. For the entry of circulation to the DHW generator 3,271 data are available, where 9.3 % show a K100-indication. The comparison of data *potable water at the outlet of the DHW generator* and *entry of the circulation to the DHW generator* show, that a significant reduction of the legionella contamination caused by the circulation is done by the DHW generator.

3. Partly central contamination

As shown in Figure 3.1, the K-100 indication for the sections of *Mixed water MW* is 30% and for *Potable water (cold) PWC* is 21% – both well above the average Legionella contamination, whereas the *DHW Circulation section* is 14%, which corresponds to the average. The main reason for the high percentage rates for the PWC-section are long dwell periods combined with the increase of temperatures (undesired warming up based of ambient temperatures e. g. in channels nearby the DHW or heating installation). The percentage of the section *DHW* is 9.3%, which is identical to the *Entry of circulation* in the DHW generator. Compared to the central contamination discussed above, the share of K100-indications in the partly central pipeline sections is significantly higher – The K100-rate for Mixed Water MW is 8 times higher indication rates related to the outlet of the DHW generator. A more detailed analysis could not possible due to the lack of system descriptions and schematics.

4. Peripheral contamination

Current data did not allow us to allocate any peripheral tapping point to a single line section of the DHW or potable water system. Therefore it can be concluded only generally whether a partly central or a peripheral contamination was involved. However it is not possible to find out, if the sample was taken from a tapping point located far away or any pipe line section.

The very high percentage (28.5% from 2,021 datasets) of K-100 Legionella indication of sampled *mixed water* taken at in the peripheral, non-circulating pipeline sections nearby the tapping points attracts attention. The indication of sampled *PWC/DHW* is 14.3%, which represents an average value. Comparison with the partly central K100-indications shows that those central contaminations were mainly caused by partly central conditions for a significant Legionella growth.

Based on the statistical evaluation of the samplings, it was found that the maximum of positive legionella indication was found, as expected, in the temperature range of optimal growth for legionella, i.e. from 30 to 45°C (Figure 3.2). One of the important finds was that the current legal and feasible range for cold potable water at 20 to 25°C is actually affected by Legionella with an even higher percentage than the non-legal DHW range of 50 to 55°C.

Annex X Final Report: Toward 4th Generation District Heating

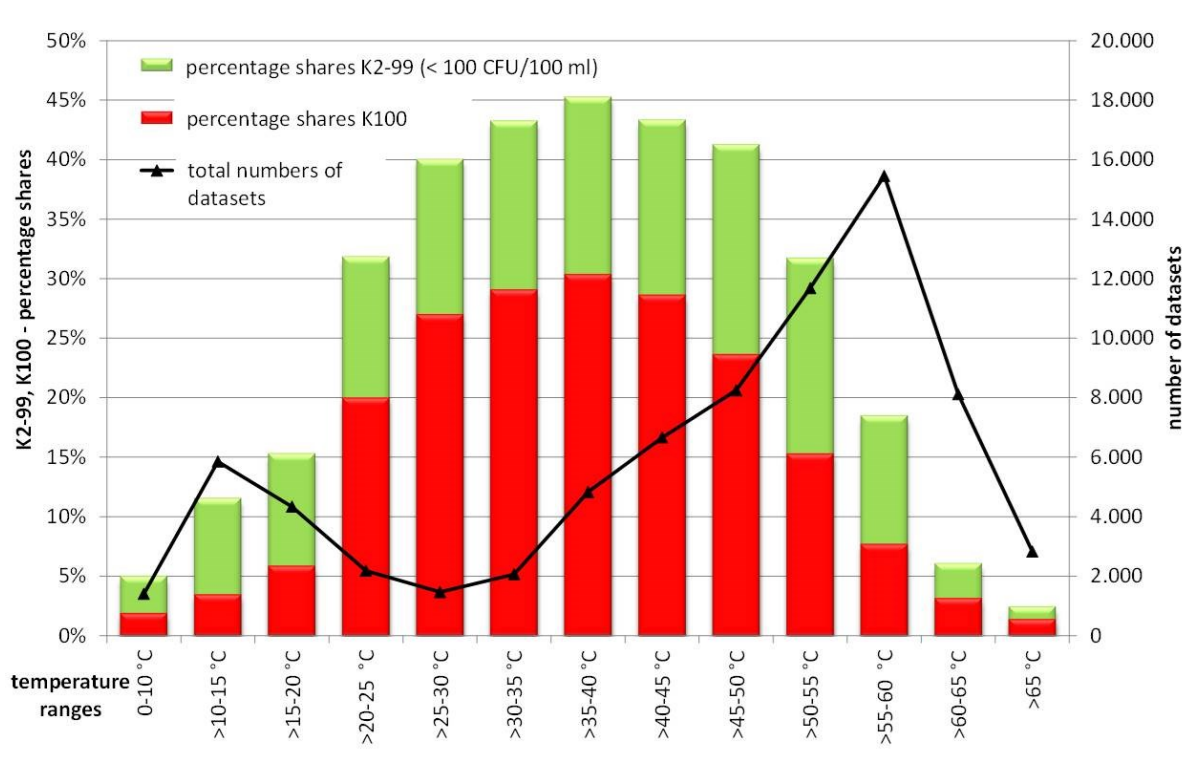

Figure 3.2 Analysis of usable datasets with positive legionella indications; split in 5-Kelvin-ranges. Source: [22].

Comparing different type of houses, nursing homes (Figure 3. 3) are most affected by Legionella. Especially for temperatures below 30°C, Legionella indications in nursing homes are significantly higher than the K100-average. It was concluded that these effects are caused by the very low tapping flow rates and the resulting long dwell times and higher water temperatures in the potable water system.

One-family houses are less affected by Legionella in the temperature range between 50 and 55°C as well as in the range between 55 and 60°C (Figure 3. 3). Reasons could be better system dimensioning and higher water tapping flow rates.

In some hospital buildings, the state of the potable water systems is under active supervision by the building management system. Only 3.2% of 12,876 datasets from these hospitals show K100-indications, which is much less than the percentage of all datasets (14.2% K100-indications). So it could be concluded that regular monitoring helps minimize the probability of Legionella growth.

Annex X Final Report: Toward 4th Generation District Heating

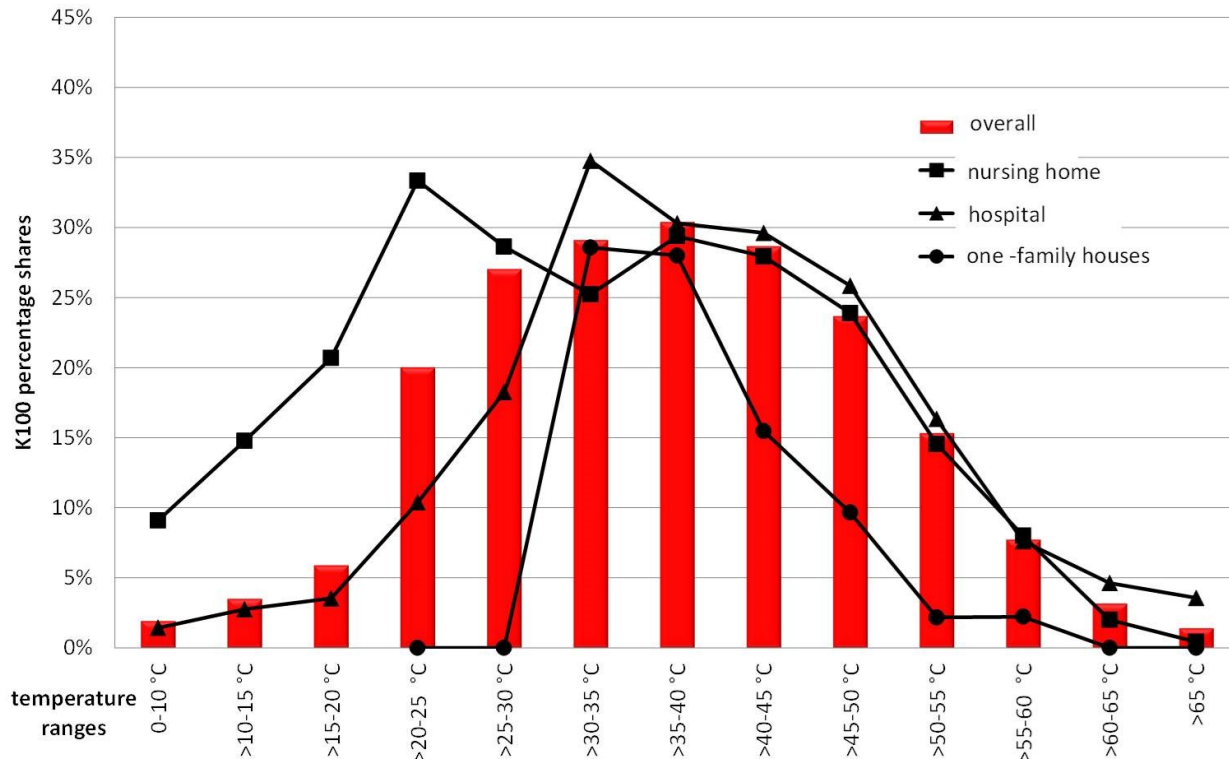

Figure 3.3 Analysis of usable datasets with legionella indications ≥ 100 CFU/100 ml (K100); split in 5-Kelvin-ranges; different building types compared to the average of all samples. Source: [22].

Number of datasets: nursing home – 8,732; hospital – 32,153; one-family-houses - 551

3,073 datasets were sampled from 171 circulation systems in DHW installations operated in active on/off mode (Figure 3.4, mainly from hotels, gymnasium and hospital). Comparing with Figure 3.3, which shows the average value of all datasets, the maximum sampling points in the circulation system shifts from 55-60°C to 40-45°C. The K100-indications in the temperature range of 30-45°C are significantly higher than the K100-indications found in the overall statistics (grey line - red markers). This is probably due to saving efforts (e.g. on/off operation of the circulation pump and reduction of DHW temperatures at the same time), which are not in line with the requirements for potable water quality.

Annex X Final Report: Toward 4th Generation District Heating

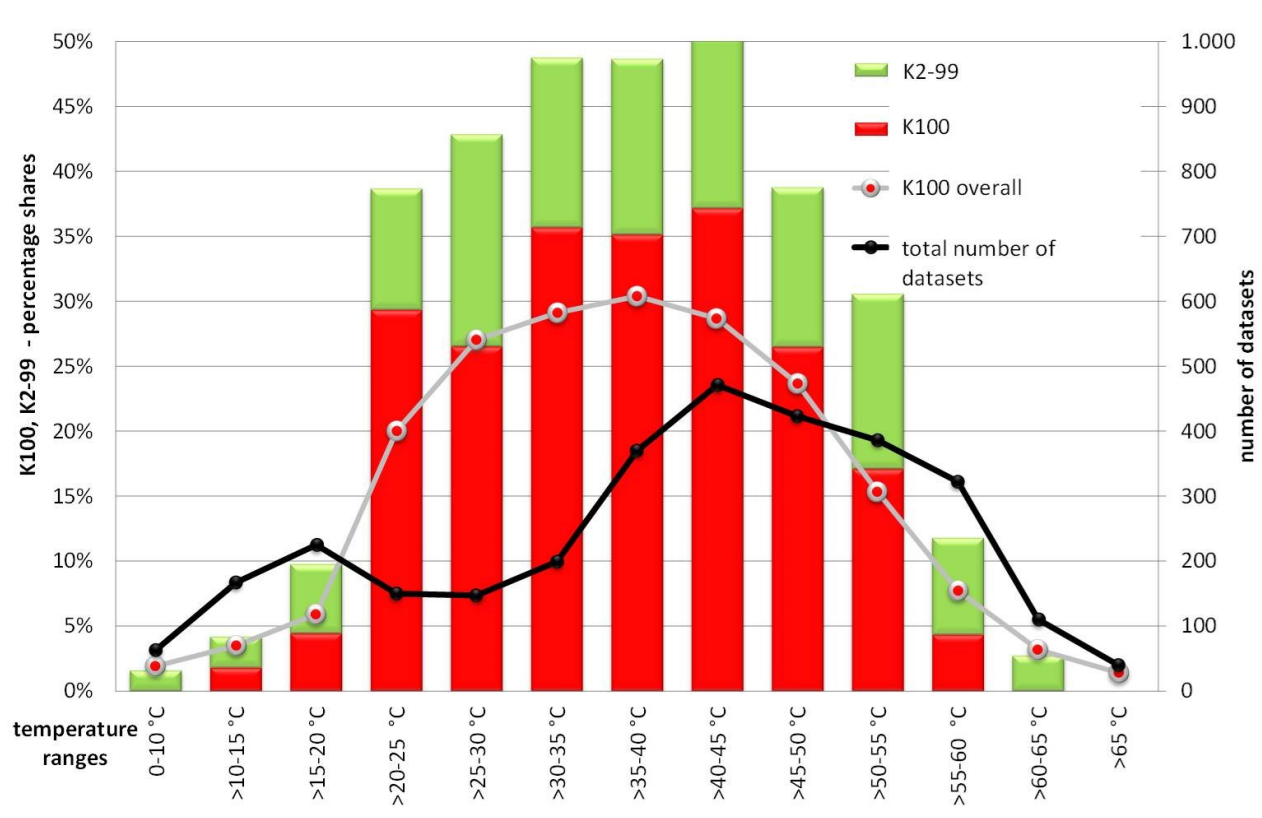

Figure 3.4 Percentage of legionella indications, split in 5-K-ranges; on/off operation of the circulation pump. Source: [22].

Summary

The technical intervention value for *Legionella* spp. according to the German Potable Water Directive is 100 CFU/100ml. The highest percentage of datasets exceeding this value are found in the peripheral section of the terminal tapping. Nevertheless, the main reasons for this ‘decentralized contamination’ are assumed to be unacceptably low temperatures in the partly central sections of the DHW system (e.g. unsatisfactory hydraulic balancing) and mixed water. But high temperatures in the pipelines of potable water (cold) due to low tapping flow rates or oversizing of pipes also often cause Legionella indications. In this respect, neither evaluation and assessment of potable water systems nor definition of measures can be productive if based only on the sampling of peripheral tapping points. The history of sampling [22] shows that for years only terminal tapping points have been sampled, which means that effective measures have not been taken.

Very few samples have been taken in the context of exclusively orienting systematic inspection. This limits the possibility for new insights with regard to the acceptability of lowering the temperature level in the DHW-system by up to 5 Kelvin in new water systems built in accordance with generally accepted codes of practice. It is planned to further fill in the database, adding also other information,

Annex X Final Report: Toward 4th Generation District Heating

e.g. the reason for the sampling, or measures taken to overcome any legionella indication). Furthermore there are still questions to be answered:

- Is it possible to reduce *Legionella* spp. contamination of potable water by avoiding any oversizing of the potable water installations, especially the DHW generator?
- Would it be reasonable to allow any DHW temperature $\geq 50^{\circ}\text{C}$, if the dwell time of the potable water is limited? Would it also help to limit the ‘unrequested’ heating of potable water inside the cold section of the potable water system?
- Do new methods of analysis that distinguish between *Legionella* spp. and *Legionella pneumophila* and also allow an evaluation of the vitality of the species lead to more accurate and suitable measures?

3.3 Legionella Treatment

The risk related to Legionella bacteria, amoebae and other microorganism growth in potable water systems has been a key-limitation in the selection of temperature levels for DHW preparation in DH substations. The advantages of low-temperature DHW systems lie not only in the potential heat savings in the DHW system in the building, but also with the consequent opportunity to widen the application of low-temperature, environmentally-friendly heat supply systems. It is very relevant to study the energy savings and opportunities that would arise if DHW temperatures could be reduced to levels close to the end-users’ real needs (DHW temperature: 40-47°C) given the fact that the options for DHW treatments against Legionella bacteria and other microorganisms that are potentially dangerous to human health can be divided into thermal treatments, chemical treatments, and physical treatments such as ultra-filtration or UV radiation. They can also be grouped in two main types: the first group is based on killing the bacteria present in the water, whilst the second group limits the concentrations of bacteria by preventing them entering the DHW system. It’s important to know, that the most of the treatment methods are allowed only for a small period (in case of a contamination situation) in any countries, not as a continuous method.

Table 3.1 Overview of technologies for DHW treatment against Legionella bacteria

Type of treatment	Description	Active substances
Thermal treatment	Flushing time with weekly flushing: 20 min (60°C); 10 min (65°C); 5 min (70°C)	None
	Reheating time: 10 min (60°C); 1 min (65°C); 10 s (70°C)	
Sodium hypochloride dosing	Short-term application for several hours with high concentration. High concentration may cause significant corrosion of copper pipes	NaOCl: minimum 20 mg/L
	Continuous low concentration in the entire system	NaOCl: up to 5 mg/L (max. 8 mg/L)
Chlorodioxide		ClO ₂ up to 1.5 mg/L

Annex X Final Report: Toward 4th Generation District Heating

dosing	Short-term application for several hours with high concentration. Minor effects on the pipe material.	
	Continuous low concentration in the entire system	ClO ₂ up to 0.2 mg/L
Chloroamine dosing	Continuous low concentration in the entire system. In the process ammonia may be released, forming strong complexes with copper, thus possibly preventing the formation of a protective covering layer	ClNH ₂ up to 2 mg/L
Hydrogen peroxide dosing	Solely for short, periodic treatment, applied for a maximum of 24 h. It kills bacteria in the entire system	H ₂ O ₂ with concentration of 200-500 mg/L. At low concentrations, the effect on pipe material is minor
Anodic oxidation/electrolysis	It kills bacteria in the entire system. Substances present in the water are converted into oxygen radicals, atomic oxygen, hydroxyl radicals, elementary chlorine and HOCl, by means of electrolysis	Organic products < 5 mg/L
Copper/silver ionization	Formation of copper and silver ions by way of ionization	Copper ions 100–400 mg/L. Silver ions 10 -40 mg/L
Membrane filtration	Microfiltration and ultra filtration to keep out incoming bacteria	None
UV disinfection	Local UV radiation which kills passing bacteria	None
Electrical pulses	Electrical pulses affect the bacteria cell walls	Presumably none

3.4 Low-Temperature Protection Systems

Essentially, we propose two ways to supply safe DHW from LTDH: by means of proper design of in-house DHW preparation and distribution systems (valid for small systems), and low-temperature water treatment (to be used in large buildings). The expressions “small systems” and “large systems” refer to the definitions in the German and French codes of practice for DHW installations.

3.4.1 Proper Design of in-House DHW Distribution Systems in Small Buildings

In new single-family buildings, such as detached or semi-detached houses and terraced houses, the layout of the DHW distribution pipes and the floor plan of each home can be designed with individual connection of DHW feeding pipes between the source of DHW and each tap, and with optimally reduced pipe diameters, defined by the requirements for noise propagation and pressure drop. Consequently, the water content in each DHW supply line, including the volume in the secondary side of the DHW HE can be kept below 3 L. This is in line with German Standard W551[25] which states

Annex X Final Report: Toward 4th Generation District Heating

that if the total volume of a DHW system can be kept below 3 L, the temperature of DHW can be below 50°C with no risk of Legionella promotion.

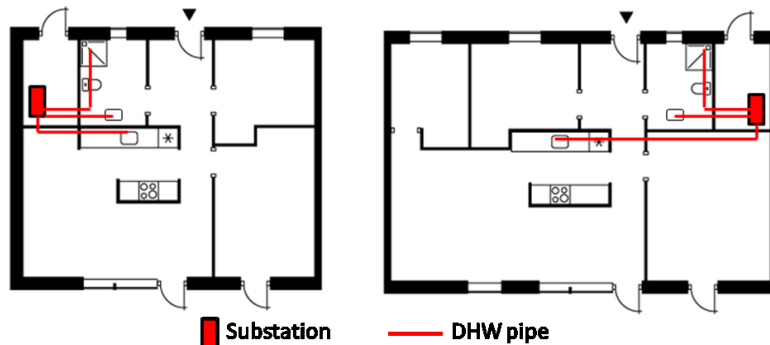

Figure 3.1 depicts a real-life example in the LTDH system at Lystrup, Denmark.

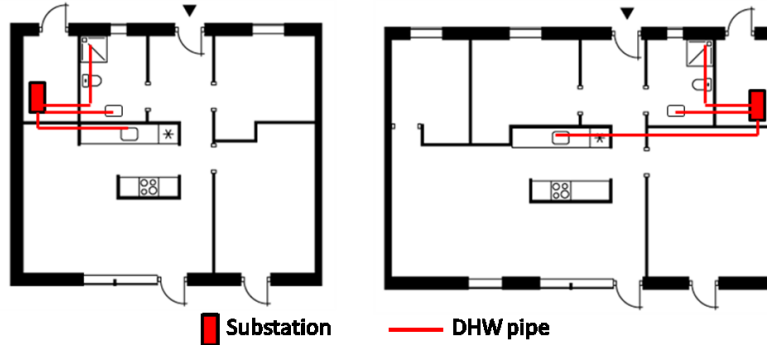

Figure 3.1 Sketch of the floor plans with the layout of the DHW distribution pipelines in the two types of home at Lystrup, Denmark. Source: [15].

Chapter 4 describes two low-temperature DHW substations: the low-temperature Instantaneous Heat Exchanger Unit (IHEU), and the low-temperature District Heating Storage Unit (DHSU).

In new multi-family buildings, a similar concept can be applied, provided that every apartment has its own DHW substation, instead of central equipment for DHW production. The same can be done in existing buildings, but economic considerations may outweigh the benefits of renovating the existing DHW preparation and distribution equipment; if the capital investments required are not acceptable, effective low-temperature systems are available and are described in the following paragraphs.

3.4.2 Low-Temperature Water Treatment in Large Buildings

A full-scale research project is being carried out in Sweden – based on an earlier pilot study in 2011. It demonstrated that a combination of reduced tap water temperatures and bactericidal technology can both save energy and enhance protection against Legionella [26]. Ten property types were included in the 6-month long study, all of which were equipped with systems for water treatment against Legionella bacteria. Their bactericidal effect enabled DHW temperatures to be reduced below 50°C. The level of relevant bacterial contamination of the DHW system was continuously monitored through

Annex X Final Report: Toward 4th Generation District Heating

online measurement and sampling of the water flows and sampling of shower water. The project helped extend our knowledge and understanding of the ways in which Legionella and other bacteria behave in real residential buildings; the study generated a body of data that can be used for preparing recommendations on the use of reduced DH supply temperatures and reduced DHW temperatures using technology that eliminates Legionella bacteria, irrespective of water temperature. The technology complements conventional bactericidal methods (based on thermal treatment), with a chemical-free bactericidal methodology.

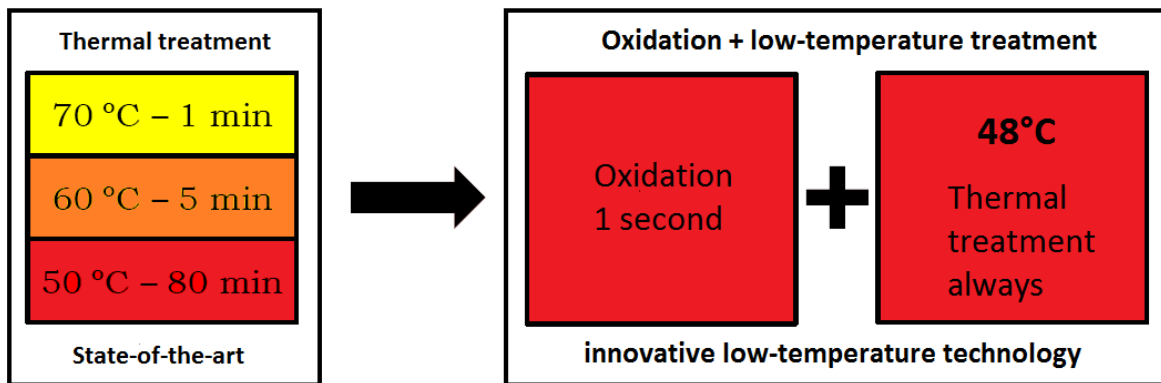

Figure 3.5 Comparison between the standard bactericidal technology based on thermal treatment of the water and the oxidation technology proposed in the study by Teknikmarknad (reference: log-5 reduction of Legionella concentration). The latter combines the oxidation technology with a DHW temperature of 48°C, which is maintained in the whole distribution system. Source: [26].

The technology consists of a combination of oxidation technology – in which a bactericidal effect of up to 99.999% (“log 5-barrier”) is achieved at every barrier protection with regard to Legionella and amoebae – with a DHW temperature of 48°C in the DHW system. Biological substances that form biofilm are also broken down, reducing the build-up of biofilm in the pipes, which creates the optimal environment for Legionella. The health issues connected with Legionella bacteria and amoebae are eliminated, even at temperatures below 50°C.

The goal is to reduce the DHW temperature in residential and commercial buildings to the target range of 40-47°C, which is the temperature level required by users. This not only achieves massive energy savings, thanks to the wide range of applications for the method, but also fulfils the demands of the future LTDH systems with a supply temperature to the entry point of the buildings down to 50-52°C.

The research project was structured as a pilot project comprising ten building complexes. The properties were of varying types and located in different parts of Sweden. The properties underwent the following stages in parallel during the course of the project to ensure comparable preconditions.

1. Installation of the bactericidal systems

Annex X Final Report: Toward 4th Generation District Heating

2. Rinsing with low concentration chlorine dioxide (in order to clear the in-house DHW system of any existing bacteria colonies)
3. Start-up of the bactericidal system
4. Continuous monitoring by sampling without lowering the temperature ($T > 60^{\circ}\text{C}$)
5. Gradual temperature reduction
6. Continuous monitoring by sampling:
 - Two online measurement units/particle counters
 - Shower and DHW samples

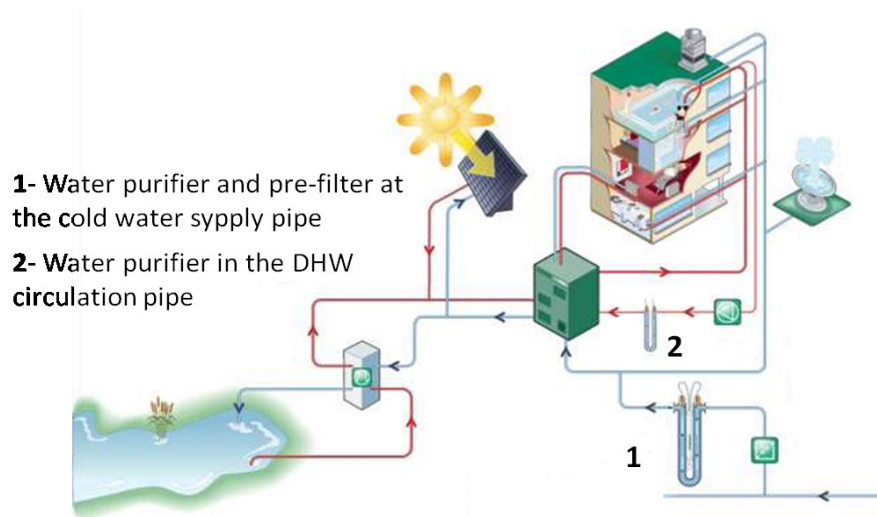

Figure 3.2 Example of installation of the anti-Legionella equipment in a multi-family building. Source: [26].

The chemical-free barrier protection against Legionella was installed in two places in the DHW system: at the cold water intake to the building's DH substation, and at the DHW supply pipe or re-circulation pipe, see Source: [26]. for a practical example. The advantages of installing the equipment in the cold water supply pipe lie in the minimization of Legionella bacteria entering the in-house installations, the treatment of the whole water entering the building, and the double treatment of the DHW, before and after the heating process.

Annex X Final Report: Toward 4th Generation District Heating

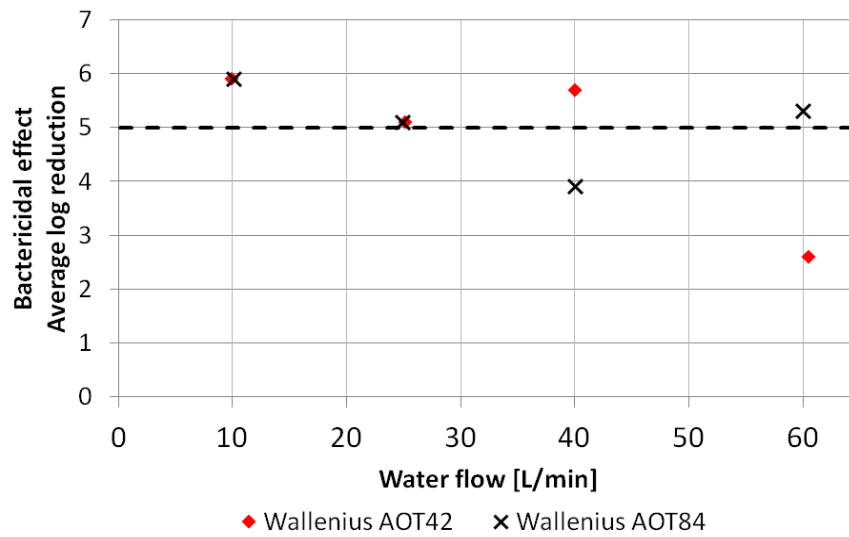

Figure 3.6 Graph showing selection of size of oxidation equipment with the bactericidal effect on Legionella shown as a function of the water's flow. Source: [26].

Limitations

The research project demonstrated that enhanced Legionella protection enables a reduction in the DHW temperature. As shown in Figure 3.6, the oxidation technology has a log-5 bactericidal effect. In the majority of buildings, no other measures are deemed necessary. Nevertheless, there are buildings with secondary pipe systems, such as dead-end pipes, where the water is stationary and where the oxidation technology cannot reach. While the protective oxidation barrier effectively treats the incoming and circulating DHW, it has no access to external system components, such as dead-end pipes and shower heads. Legionella colonies that survive in these parts can grow and even spread to other parts of the system due to the system temperatures of <math><50^{\circ}\text{C}</math>. It is therefore important that a system is cleared of bacteria before the installation of the low-temperature oxidation barrier. This was shown by the fact that in the buildings where Legionella was already present in the DHW circulation system before the installation of the oxidation equipment, the technology did not reduce the bacteria concentrations. Special measures may be needed to counteract any Legionella growth that occurs specifically in those locations.

Recommendations

- There is a need for a comprehensive methodology to ensure the proper commissioning of DHW systems in buildings. European and national legislation is needed.
- There has been a lot of technological development on alternatives to high-temperature (>55°C) water treatments, but as yet there is no standard procedure for their systematic evaluation and comparison. The technology proposed here refers to a valuable recent, full-scale research project that

Annex X Final Report: Toward 4th Generation District Heating

demonstrated that low-temperature DHW treatment through oxidation is effective, fits the requirements of low-temperature systems, and therefore has wide potential for application.

- Oxidation technology has proven to be valuable both for providing safe DHW and for enabling extensive reduction of heat loss, particularly in buildings supplied by DH. In Sweden, a nationwide application of the concept is expected, once the full-scale research project is completed (2011-2013) and a set of regulations is compiled. Most new and existing buildings in other countries could also carry out this type of measure, particularly if there is a simultaneous shift towards low-temperature heat supply systems, such as LTDH.

4 Domestic Hot Water Installation

The potential for energy savings in the building sector relies not only on the improved design of the building envelope, but also on improved integration and control of efficient building energy service technologies, such as space heating/cooling, ventilation and DHW systems. Innovative DH units have to be designed in such a way that they can deliver heat for DHW and SH efficiently, provide high thermal comfort, and be cost-effective and reliable. In this chapter, we describe concepts for low-temperature in-house DHW and SH units for single-family houses and multi-storey buildings.

4.1 Low-Temperature Substations in Single-Family Houses

An effective and efficient DH substation has the function of guaranteeing the hygienic and reliable supply of DHW and SH, assuring customer thermal comfort, and providing effective cooling of the DH water. A typical DH substation consists of HEXs, a pump, and thermal and hydraulic controllers. A storage tank may also be used to store DHW thus decreasing the load capacity in the DH network during periods of DHW peak demand. **Fejl! Henvisningskilde ikke fundet.** shows two traditional concepts of DH substation units: the one on the left uses a HE for instantaneous preparation of DHW and it uses water from the DH network directly for SH; the one on the right uses a DHW storage tank.

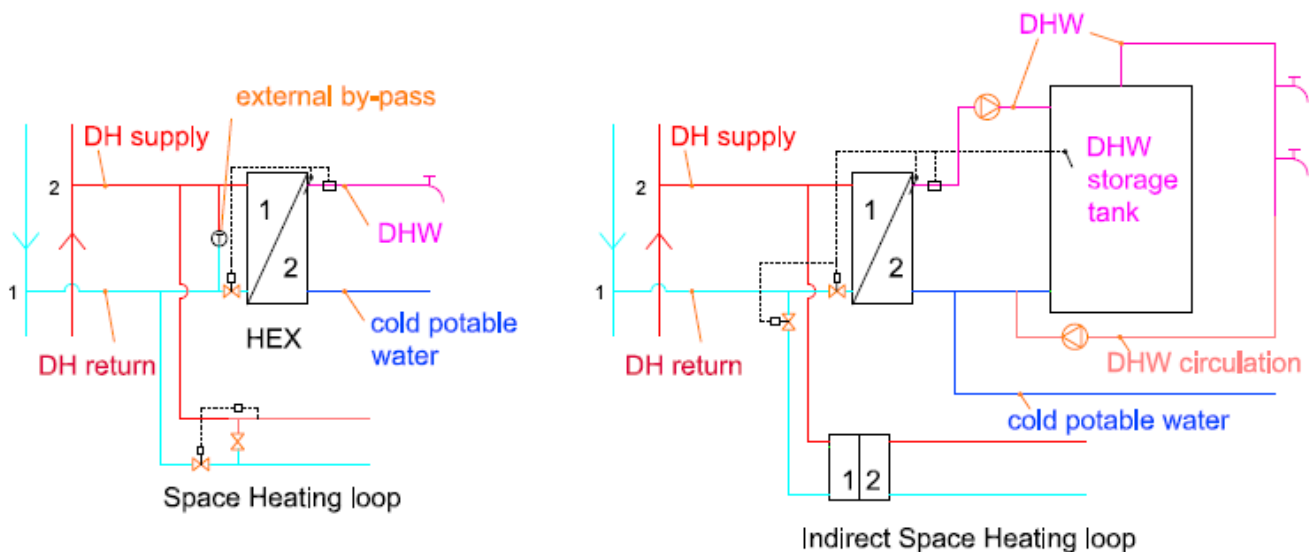

Figure 4.1 Left: Instantaneous HE for DHW and direct connection of SH loop. Right: Traditional DHW Storage Tank (DHW-STU) and indirect connection of SH loop.

There are two types of DH network connection to the SH system: indirect and direct. In the indirect system, a HE is installed to separate different pressure levels, so that a higher pressure is allowed in the upstream network. The direct connection allows water in the DH network to circulate directly into the end-user SH system. This is suitable for networks with moderate pressure levels, where the differential pressure of the DH network is sufficient to circulate water to the home installation. The home installation is designed to withstand the maximum static pressure in the network. The advantage

Annex X Final Report: Toward 4th Generation District Heating

of the direct connection is that the temperature drop along the network is reduced when there is no HE. The figure on the left shows the SH provided by the direct system.

In a low-temperature DHW system, the in-house substation design should aim at reducing the water content in the DHW system and at the elimination of DHW recirculation wherever possible, so that the Legionella growth condition can be restrained even when the DHW temperature goes below 50°C. There are several ways of designing and implementing low-temperature DHW systems and low-temperature in-house substations.

Two examples of low-temperature solutions are given below. They have been already implemented in practice in the LTDH scheme at Lystrup, in Denmark (see the case studies in chapter 9).

4.1.1 Instantaneous Heat Exchanger Unit (IHEU)

The most important parameters for an IHEU are the recovery time (i.e. the time it takes for the substation to produce DHW at the right temperature once water tapping has started), the stability of the DHW temperature, and the cooling of DH water during operation. Their evaluation is important for the assessment of the level of users' comfort and energy efficiency.

The detailed operating performance of the low-temperature IHEU prototype installed at Lystrup was measured in the experimental facilities at the Technical University of Denmark. Full details are available in [27]. The main conclusions were:

- The low-temperature IHEU works properly, being capable of preparing DHW at 47°C with a primary supply temperature of 50°C. It guarantees the proper cooling of DH water during tapping, e.g. the primary return temperature, T_{12} , is below 20°C when the secondary inlet temperature, T_{21} , is 14°C. Hence, the installed number of transfer units (NTU) is 7.6, which is almost twice the thermal length used in current heat exchangers. NTU is the standard parameter for designing heat exchangers. It is defined by the ratio between the capacity to transfer heat and the lowest capacity flow through the heat changer or by the ratio between the temperature difference for the lowest capacity flow and the logarithmic mean temperature difference across the heat exchanger.
- The recovery time to prepare DHW at 42°C, when the maximum primary flow rate is 14L/min, depends on the temperature conditions when the DHW tapping starts, but it is between 7 s and 12 s. The upper limit refers to the least favourable conditions, i.e. long idling without bypass flow, whilst the shortest recovery time occurs during the second tapping event of two successive tapping events (e.g. when the second tapping event occurs 5 minutes after the previous tapping stopped).
- The controller for operating the IHEU with internal bypass should be re-designed to accommodate low-temperature operations, because the temperature levels lie outside of the standard range for temperature control. In a standard controller, the condition for proper functioning is that $T_{22} - T_{11}$ is approx. 10°C, which is not possible when the target DHW temperature T_{22} is set to 42-47°C and the primary supply temperature, T_{11} , is 50°C.



Figure 4.1 Picture of a low-temperature IHEU

4.2 Low-Temperature District Heating Storage Unit (DHSU)

The traditional DHW storage tank unit has the tank on the secondary side (the end-user's side), which does not fit the requirements of low-temperature DHW systems due to the Legionella risk in the large-volume DHW storage. To avoid health issues while retaining the advantage of energy buffers, in the DHSU concept the storage tank is placed on the primary side (the DH side) instead. Figure 4.2 shows a photograph of the prototype. The storage volume is either 120 L or 175 L and the corresponding design primary flow is respectively 75 L/h or 40 L/h to accommodate the DS439 DHW tap patterns in a single-family house without a bathtub. The volume of the storage tank is sized based on the total daily DHW draw-off profile, considering factors such as the space requirements and an appropriate hydraulic load in the network.

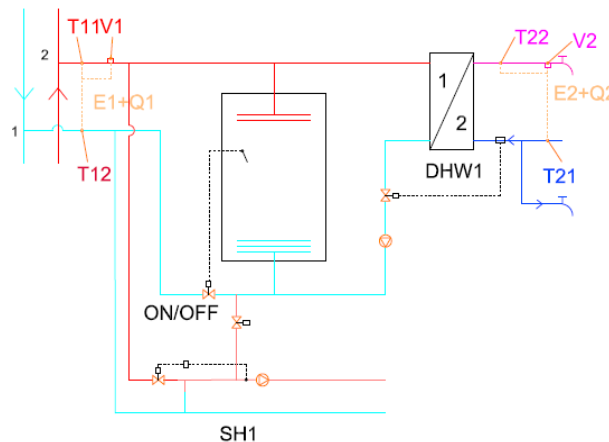

Figure 4.2 Picture and scheme of the district heating storage unit.

Annex X Final Report: Toward 4th Generation District Heating

The performance of the *low-temperature DHSU* prototype has been tested at the Danish Technological University test house (the “EnergyFlexHouse”) with the objective of analysing and evaluating the performance of the concept in a real low-energy house. The tests were carried out with a DH service twin pipe with media pipe inner/outer diameters of 10/14 mm and an outer-casing diameter of 110 mm, corresponding to insulation series 2. The tests were carried out on the prototype DHSU with a 175 L storage tank on the primary side (DH side). Three different DHW tapping patterns were used: one based on the Danish Standard DS 439 and two based on the European standard PrEN50440 (tapping profiles M and L). The results showed that balancing the primary loading flow in relation to actual tapping patterns and DHW use is important if the DH return temperature is to be kept as low as possible. The primary loading flow should then be calibrated to a value that corresponds to the DHW use pattern.

The DHSU has the advantage that it shaves the peak load demand and allows a low charging flow rate of DH water. As a consequence, the service pipe and its connected distribution pipes can be designed with smaller diameters, thus reducing network heat loss. However, the network dimensions for IHEU and DHSU depend greatly on the selection of simultaneity factors (SF). The measurements from the Lystrup project indicate that the SF selected for IHEU can be much lower than with the traditional design parameters. After the first several consumers, the corresponding distribution network can therefore be dimensioned in the same way as the DHSU. This may make the DHSU less advantageous with regard to the total heat loss reduction due to its higher heat loss from the storage tank.

Moreover, the current minimum service pipe diameter for commercial district heating pipe is Alx 14/14/110, with 10 mm inner diameter. If we reduce the service pipe diameter any further, we may run the risk that impurities in the DH water could block the pipe. For the DHSU with a 120 L storage tank, the total design heating load is 7.3 kW with a DHW design load of 4.7 kW and a SH design load of 2.6 kW (as in the Lystrup project). The calculated flow velocity is 0.74 m/s and the pressure drop is 0.1bar for a 10 m long service pipe. These values are far below the network design criteria, showing that the available network pressure is not fully used for the current DHSU design.

Alternatively, instead of using large volume storage tank, a compact DHSU with a volume of 30-40 L, enough for a standard shower, might be a more effective solution. Such a design would reduce the tank heat loss while making full use of the available network pressure gradient. However, the use of storage tank units in low-temperature district heating needs to be further justified based on better SF measurements and an overall thermal and economic performance evaluation.

4.3 Space Heating and Domestic Hot Water Systems in Multi-Storey Buildings

DHW and SH systems in multi-storey buildings are usually designed with the heat source located centrally in a service room; the heat is distributed by vertical risers to individual flats. There are several possible configurations, see Figure 4.3. Centralized DHW systems have large-volume storage tanks for DHW and tend to have problems meeting comfort and hygiene requirements. The main problems are hydraulic unbalance in the risers, the relatively high heat loss in the circulation pipelines, and the metering of DHW use. With regard to SH, one common disadvantage is the impossibility of individual

Annex X Final Report: Toward 4th Generation District Heating

control of the heating, e.g. to use the night set-back (decreasing of the indoor operative temperature during the night). We can distinguish two types of traditional centralized SH installation:

- Vertical riser systems (see Figure 4.3 – system A): in this design layout, the possible problems include the noise propagation between individual storeys through the vertical risers, and the complex metering of heat use: each radiator has to have an individual meter.
- Horizontal SH systems (see Figure 4.3 – system B): the initial investment is higher than in vertical SH systems, because the total pipeline length is usually greater, but only one meter per flat is needed for energy metering.

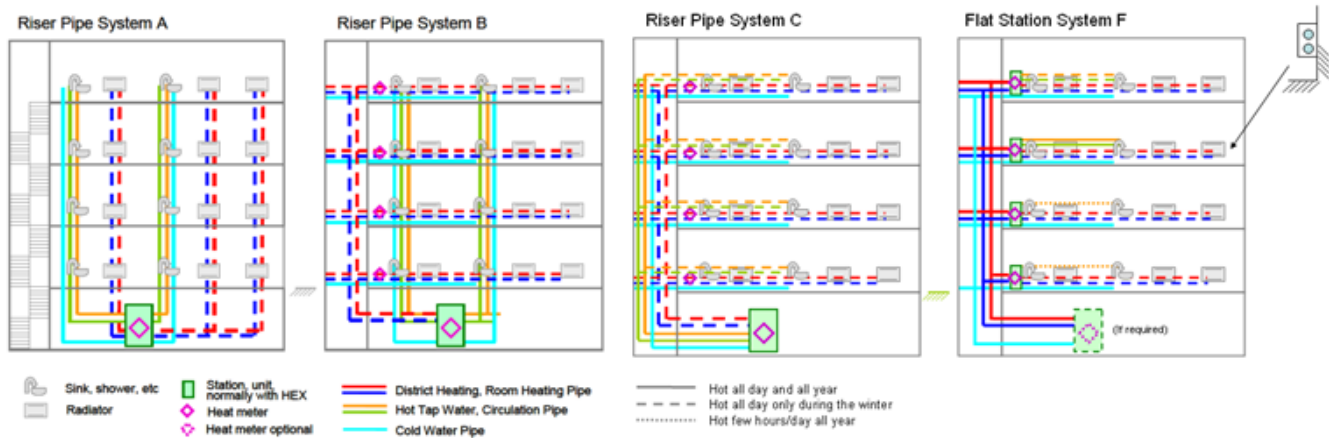

Figure 4.3 Three main design options for DHW and SH distribution in multi-storey buildings (source: Danfoss).

The state-of-the-art for DH substations in multi-storey buildings is the flat/apartment station concept [28]. In the flat station concept, the DH water is distributed by risers to each storey and every flat has its own compact substation for DHW preparation and SH. The type of substation is the IHEU, due to its limited space requirements. The main advantages of the flat station concept are:

- Decentralized, individual supply of DHW for each flat, which avoids DHW circulation (saving energy) and limits the Legionella risk (hygiene);
- Complete individual control of the SH system;
- Simple and precise energy metering.

The low-temperature flat station unit is based on improvements to the traditional flat station for high and medium DH systems. The main difference is that the supply temperature on the primary side is only marginally higher than the DHW temperature required. This means it is necessary to guarantee optimal control strategies and a bigger heat transfer surface. The HE unit for single-family houses and

Annex X Final Report: Toward 4th Generation District Heating

multi-storey buildings can be very similar, so that efficient and standardized manufacture of the products is possible.

Flat substation with centralized buffer tank

HE units are installed in the individual flats and a central tank for DH water storage is located in a technical room. The buffer tank operates only in periods of high DHW use.

Flat substation with decentralized buffer tank

This solution is based on the same concept as the DHSU for single-family houses. The difference is that the volume of the buffer tank is smaller because of space limitations. The size of buffer tank should be investigated, but as an initial proposal we suggest a 30-40-litre tank, ideal to guarantee the DHW needed for a “standard” shower.

In practice, economic considerations may outweigh the benefits of renovating the existing DHW preparation and distribution equipment; if the capital investments required by the “flat substation” are considered not acceptable, effective low-temperature water treatment systems are available, such as the one described in paragraph 3.4.2 above. It is suggested that the designer should aim at combining reduced DHW temperatures and chemical/bactericidal technology for DHW treatment. That will not only save energy, but it will also enhance the protection against Legionella.

5 Low-Temperature District Heating Supply Low-Energy Building

5.1 Introduction

This part of the report compares SH systems commonly used in low-energy houses in order to provide an overview of the differences among the SH equipment and installation options, taking into account the users' thermal comfort requirements and the requirements of LTDH. In these investigations, we focused on three subjects: the peak loads of the heat demand profiles, the return temperature of the DH heat carriers, and the comfort of the occupants.

As our reference building, we chose a single-family house with a heated area of 159 m² and Danish climate. The house fulfils the requirements for "class 2015" buildings, in accordance with Danish Building Regulations, 2010. The primary energy demand for SH, DHW and electricity for the operation of HVAC systems is therefore below 36.3 kWh/(m²·yr). The house is divided into 12 zones. The model was built in the commercially available software, IDA-ICE®.

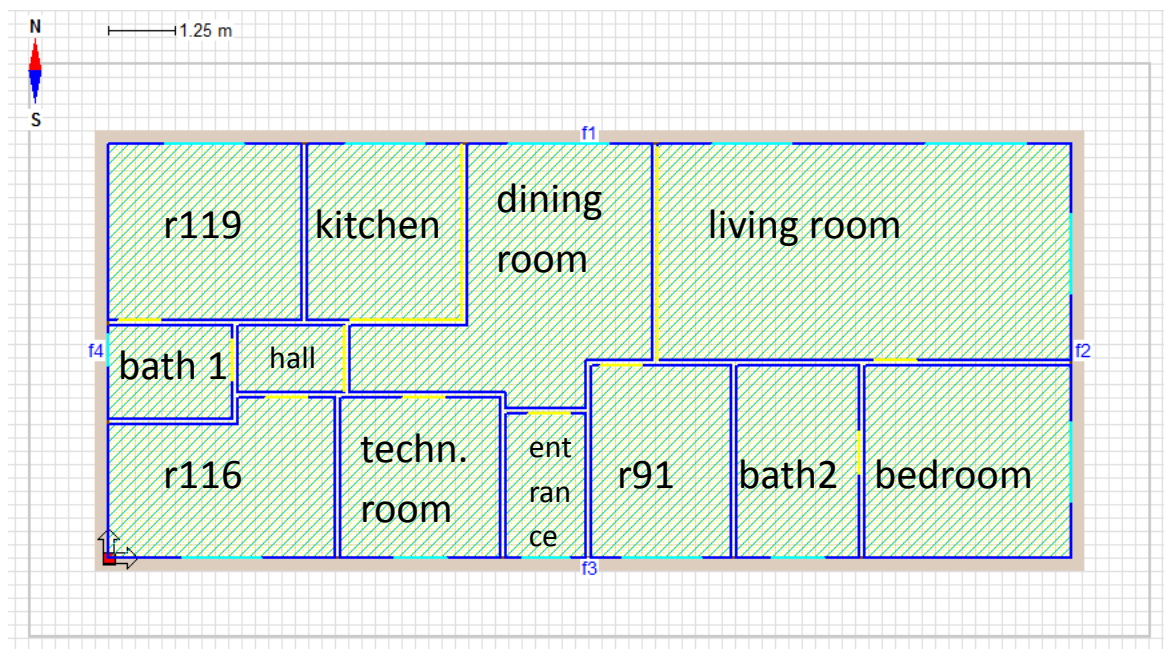

Figure 5.1 Floor plan of the 159 m² single-family house

The ventilation system supplies a total of 60L/s of fresh air divided between the bedroom, two other rooms (r119 and r116), and the office (r91), living room and dining room. The air is exhausted from the bathrooms (15L/s each), kitchen (20L/s) and technical room (10L/s). The ventilation system is equipped with a counter-flow heat recovery with a thermal efficiency of 76% and frost protection. The frost protection system (bypass of the incoming air) is activated when the exhaust air temperature is below 1°C after the heat recovery unit. The design supply air temperature to the rooms is 16°C. This value was chosen to keep good thermal comfort in the rooms facing south during spring and autumn,

Annex X Final Report: Toward 4th Generation District Heating

when such rooms tend to have overheating problems, while rooms facing north still need heating. This strategy results in an increase in the heat demand by 11% in comparison with having a supply air temperature of 18°C. Nevertheless, it reduces the duration of the period with an indoor temperature over 26°C. The higher heat demand is due to the fact that the heat recovery unit operates more often in bypass mode. The exception is where there is a Forced Air Heating (FAH) installation. The only shading on the house is given by a 0.5-metre wide roof overhang.

5.2 Modelling of SH System

The comparison between the SH systems is based on state-of-the-art systems representing common design practice, but adapted to low-temperature conditions.

Radiators

In the first step, the maximum heating loads for design conditions were calculated in each room. Later, the ideal heaters were replaced with models of existing water radiators designed with conditions 55/25/20°C, including their physical and thermal characteristics. The control was modelled as a P type regulator with a 0.5°C deadband, controlled by the indoor air temperature. The water supply temperature was kept at 55°C all-year-round.

Forced Air Heating (FAH)

The FAH system was dimensioned for an outdoor temperature of -12°C (the power of the Heating Coil (HC) was dimensioned for -15°C) and no internal heat gains, in accordance with Danish design practice. Although the supply air temperature was 50°C, i.e. the maximum allowable value, it was necessary to increase the total air flow from 60 L/s to 91 L/s to provide the desired indoor temperature of 20°C in design conditions. We chose the largest commercially available HC for single-family houses (CWW 400-3-2.5, from the Swedish producer VEAB), which was capable of giving the required heating output of 4.5 kW (air heated from 9°C – temperature after the heat recovery HE, calculated by IDA-ICE for exhaust air at 20°C and outdoor air at -15°C – to the supply air temperature of 50°C) with a temperature difference on the water side of approx. 2°C. The supply air temperature/HC load was controlled by the temperature of the return air mixed from all the rooms. The set-point temperature was 20°C.

Floor Heating

The FH system was modelled as a traditional hydronic FH system in a solid floor, i.e. heating pipes embedded in a concrete floor. A 3°C-temperature difference (supply-to-return) was chosen to ensure low return temperatures, while maintaining a uniform temperature distribution on the floor surface. Each room had an individual FH loop with an electronic on/off valve controlled by the operative temperature in the room (thermostat with a deadband of 0.2°C). The supply temperature of the heating water to the FH was weather-compensated. The heating curve was characterized by three points (outdoor temperature: temperature of supplied water): [-21:35]; [-5:27]; [35:27].

Annex X Final Report: Toward 4th Generation District Heating

Table 5.1 Case studies with results from 3 different SH systems: radiators, FAH and FH. C = constant, S = scheduled; ^a outdoor temperature -12°C, no heat gains; ^b Tsetpoint 20°C/22°C; ^c Tsetpoint = 22°C

Radiator cases	Heat Gain [W/m ²]	SH Demand [kWh/yr]	Heating period [month]	Average T _{water,ret.} [°C]	Max. T _{water,ret.} [°C]	Over-Sizing				
						P _{max,rad} [W]	%	P _{max,HC} [W]	%	P _{total} [W]
Design ^a	0	-	-	25/29 ^b	-	2967	0	830	0	3797
I	5 (C)	3274	6	20.4	22.8	2154	27	1247	-50	3401
II	4.18(C)	3890	7	20.5	23.1	2298	23	1251	-51	3549
III	4.18 (S)	4029	7.5	21.2	24.5	2613	12	1258	-52	3871
IV ^c	4.18 (S)	5744	9.5	24.0	28.3	2972	0	1117	-35	4089

FAH cases	Heat Gain [W/m ²]	SH Demand [kWh/yr]	Heating period [month]	Average T _{air,ret.} [°C]	Max. T _{air,sup.} [°C]	Max. T _{water,ret.} [°C]	P _{max,HC} [W]
I	0	-	-	53.1	50	53.1	4291
II	4.18 (S)	4670	7.3	-	41.5	34.1	4300

FH cases	Heat Gain [W/m ²]	SH Demand [kWh/yr]	Heating period [month]	Average T _{water,ret.} [°C]	Max. T _{water,sup.} [°C]	Max. T _{water,ret.} [°C]	Over-Sizing				
							P _{max,FH} [W]	%	P _{max,HC} [W]	%	P _{total} [W]
I	0	-	-	26.2	30.5	27.4	4200	0	830	0	5030
II	4.18 (S)	4159	7.4	23.3	27-35	26.6	2927	30	1273	-53	4200

Heat Gain

The SH systems were designed on the basis of Danish Standard 418 (the design outdoor temperature is -12°C), without considering heat gains. The heat recovery unit was designed with a design outdoor air temperature of -15°C. The influence of internal heat gains on the SH demand and operation conditions of the SH installations was investigated for the case with radiators. For the reference case, we used constant internal heat gains of 5W/m² as suggested by the Danish Building Institute. A study of the literature resulted in suggested values of 2-5 W/m². Moreover, we defined a schedule (Cases III

Annex X Final Report: Toward 4th Generation District Heating

and IV) which gave results – when averaged over a 24-h period – equivalent to constant heat gains of 4.18W/m^2 (Case II). Case IV was derived from Case I, but the set-point temperature in the rooms was increased to 22°C . This case is seen as the most realistic example, based on the measurements in the project at Lystrup.

5.3 Results and Discussion

Dimensioning of heating systems

Fejl! Henvisningskilde ikke fundet. shows the maximal power output from the SH systems for the simulated cases. It also shows the percentage of over-dimensioning of SH systems and HCs in comparison with the design case. With radiators and constant heat gains of 5W/m^2 , the peak heating load is only 73% of the design output. On the other hand, the traditional “static approach” results in under-dimensioning of the HC by approx. 50%. If the HC does not heat up the air to the required temperature, it will be compensated for by radiators in the individual rooms, but the return temperature from the radiators will increase for that period.

With FAH, the maximal load for the heating coil during design conditions fits the load needed for simulation with Danish Reference Year (DRY) and internal heat gains, i.e. 4.3 kW. It is interesting that in Case II the air supply temperature required was only 41.5°C , while in the design case the air supply temperature needed is 50°C . This can be explained as follows. In the design case (no heat gains), the air is heated from -15°C (3.6°C after heat recovery) to 50°C . Simulating with DRY and internal heat gains for the coldest period, the air is heated from -21°C (0°C after heat recovery) to just 41.5°C , and that due to the internal heat gains and the thermal inertia of the house. This finding should be considered when designing the heat recovery unit. Moreover, it might be possible to reduce the ventilation flow rate (ensuring that the set air supply temperature of 50°C is reached): in the case considered, the reduction would be from 90 L/s to 65 L/s. The benefits would be lower operational costs and/or the possibility of downsizing the ventilation system.

The traditional designing approach for FH systems results in over-dimensioning by 30%. Nevertheless, the situation is more complex in case of FH because of the thermal capacity involved, which slows down the heat transfer from the FH.

Influence of heat-gain modelling on the heat demand and on the duration of the heating period

If radiators are used, the reduction of internal heat gains from 5W/m^2 to 4.18W/m^2 extends the heating period from 6 months to 7 and increases the heat demand by 19%. The scheduled distribution of internal heat gains further increases the heating period from 7 months to 7.5 and the heat demand by an additional 4%. If the indoor temperature set point is increased to 22°C , the heating period is extended to 9.5 months and the heat demand increases by 75% in comparison with the reference case.

If FAH is used, it is difficult to fairly compare the results with the other SH systems investigated, because the indoor temperature in some rooms is below 20°C in certain periods (further discussed in the paragraph below about thermal comfort). This explains why the heating period with FAH is shorter

Annex X Final Report: Toward 4th Generation District Heating

than with radiators. However, the annual heat demand exceeds the radiator Case III by 16%, due to the greater ventilation rate (91 L/s) and the resulting higher ventilation loss.

With FH, the heat demand and the duration of the heating period are very similar to the case with radiators. The higher heat demand is caused by the FH thermal inertia, which sometimes results in temperatures higher than the set-point temperature.

Return water temperature from SH systems

The average return temperatures from the different SH systems are reported in **Fejl! Henvisningskilde ikke fundet.** In the design case, the radiators gave a return temperature of $25 \pm 0.15^\circ\text{C}$. The return temperature increased to 29°C when the indoor set-point temperature was 22°C . The annually averaged return temperature for all the investigated cases with an indoor temperature of 20°C was around 21°C . If the indoor temperature was increased to 22°C , the average return temperature increased to 24°C . Since the design temperature drop in the radiators is 30°C , the flow needed to supply the desired heat load is extremely low, and this can cause problems with the operation of thermostatic valves mounted in the radiators. The minimal controllable flow for thermostatic valves is generally 0.02 L/min^4 and most of the radiators were operated with the water flow below this limit. The solution is either to design suitable valves or to design and operate the radiators with a lower supply temperature. The latter solution would result in higher flow, but also in higher return temperatures.

For the design case (*Case I*), the FAH system supplied 50°C warm air and maintained the air temperature in all rooms in the range $20 \pm 0.25^\circ\text{C}$. The HC operated with temperatures $9/49^\circ\text{C}$ and $55/53.1^\circ\text{C}$ on the air side and water side, respectively. With the introduction of constant internal heat gains and weather data (*Case II*), the maximal air supply temperature dropped to 41.5°C (coldest day in DRY, $h=168$). For most of the heating season, the HC was heating air from 15°C to 30°C and the average weighted water return temperature from the HC was 18.2°C .

For the design conditions (*Case I*), the supply and return water temperatures in the FH system were 30.5°C and 27.4°C , respectively, which corresponds to the design temperature difference of 3°C . When the FH system was operated with the DRY weather file as boundary conditions and scheduled internal heat gains of 4.18 W/m^2 , the average return temperature was reduced to 23.3°C .

Heating-load profile

From a DH perspective, the maximum heating load defines the required capacity of the heat sources. The peak primary water flow – which depends on the maximum heating load and on the cooling capabilities of the building's SH and DHW installations – has a similar importance, since it defines the media pipe dimensions required in the DH network. Figure 5.2 shows the primary water flow required to supply the SH systems investigated and their return temperatures for the most critical period of the year, which is the period with the lowest outdoor temperature. The DH supply temperature was fixed

⁴ According to www.mma.se (2012)

Annex X Final Report: Toward 4th Generation District Heating

to 55°C. FH systems are operated in on/off mode, which results in more peaks in the heating-load curve, whilst radiator and FAH systems are operated more continuously. The return water temperature was similar in all the cases, except for the higher temperature and flow with FAH, caused by a limited supply-to-return temperature difference on the water side of the HC at very low outdoor temperatures. The radiator system had the lowest maximal flow (1.2 kg/s), followed by FH system with 2 kg/s and FAH with 2.8 kg/s.

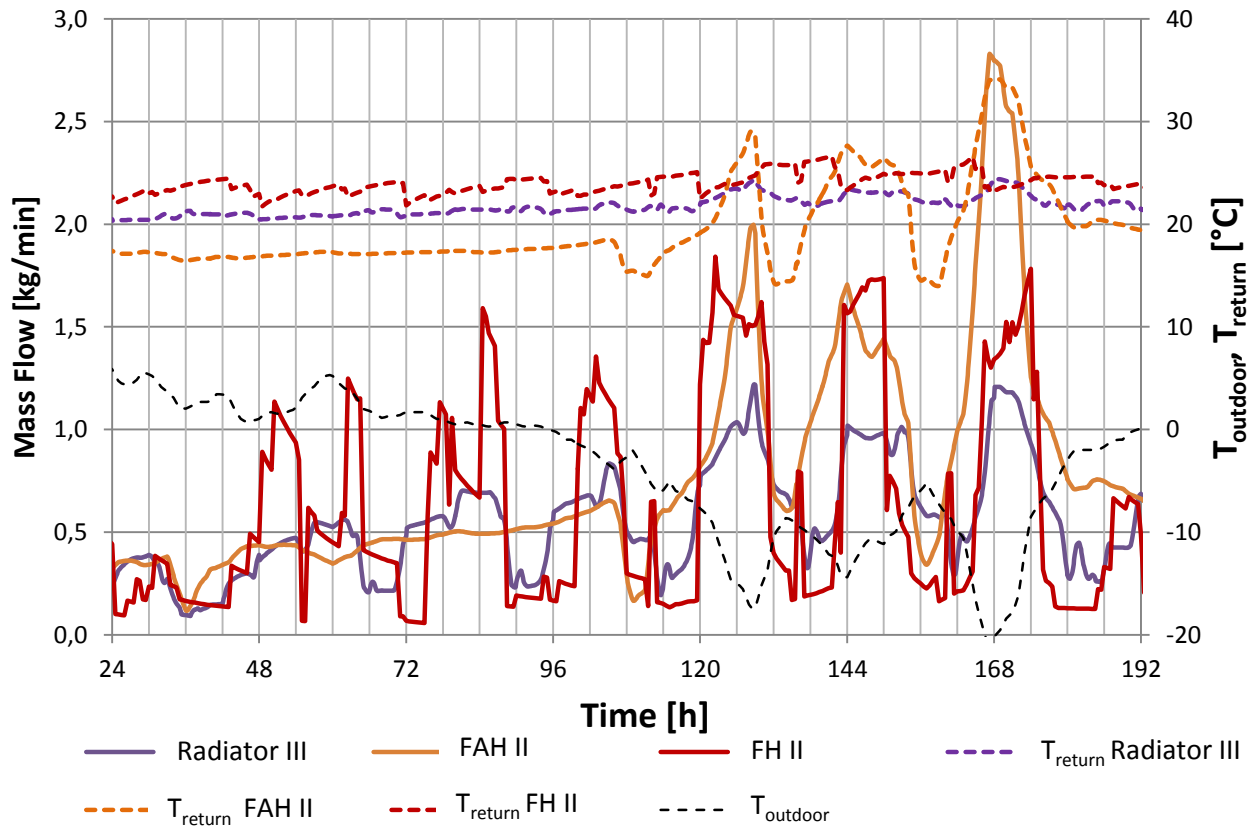

Figure 5.2 Primary (DH side) water for different SH systems: $T_{supply}=55^{\circ}\text{C}$.

Thermal comfort

The radiator-based system provided the highest level of thermal comfort thanks to its fast reaction to changeable conditions. Moreover, the air temperature in any room never dropped below the set-point temperature (20°C). For a very limited period, the minimal operative temperature was 19.7°C, which was caused by the fact that the simulated radiators are controlled by air temperature, instead of operative temperature as with a real thermostatic sensor.

Annex X Final Report: Toward 4th Generation District Heating

The FH system provided similar results. However, FH has a certain degree of response-delay, because of the larger thermal mass involved, so the minimal operative temperature for some short periods dropped to 19.5°C (for a total of 260 hours in the worst case, room r119).

FAH was the system that provided occupants with the lowest thermal comfort. FAH is controlled by exhaust air temperature mixed from all rooms and although the mixed exhaust air temperature was 20°C, some rooms were continuously overheated while others were underheated. Figure 5.3 shows the comparison of operative temperatures in the coldest (bedroom) and warmest rooms (r116). This situation often occurs and is very similar for all rooms with north-oriented windows, low internal gains or high supply air flow. The results show the major drawback of FAH systems controlled by exhaust air temperature. It also shows that the use of single-zone models for FAH simulations gives wrong results. The situation can be improved by dividing FAH into two loops based on room orientation, but this will increase the price of the system because it will need two separate HCs (i.e. one additional), and the drawback of the lack of individual control will still exist. Moreover Figure 5.3 shows that using constant internal HG results in air temperatures closer to the desired value of 20°C than in the more realistic case with scheduled HG.

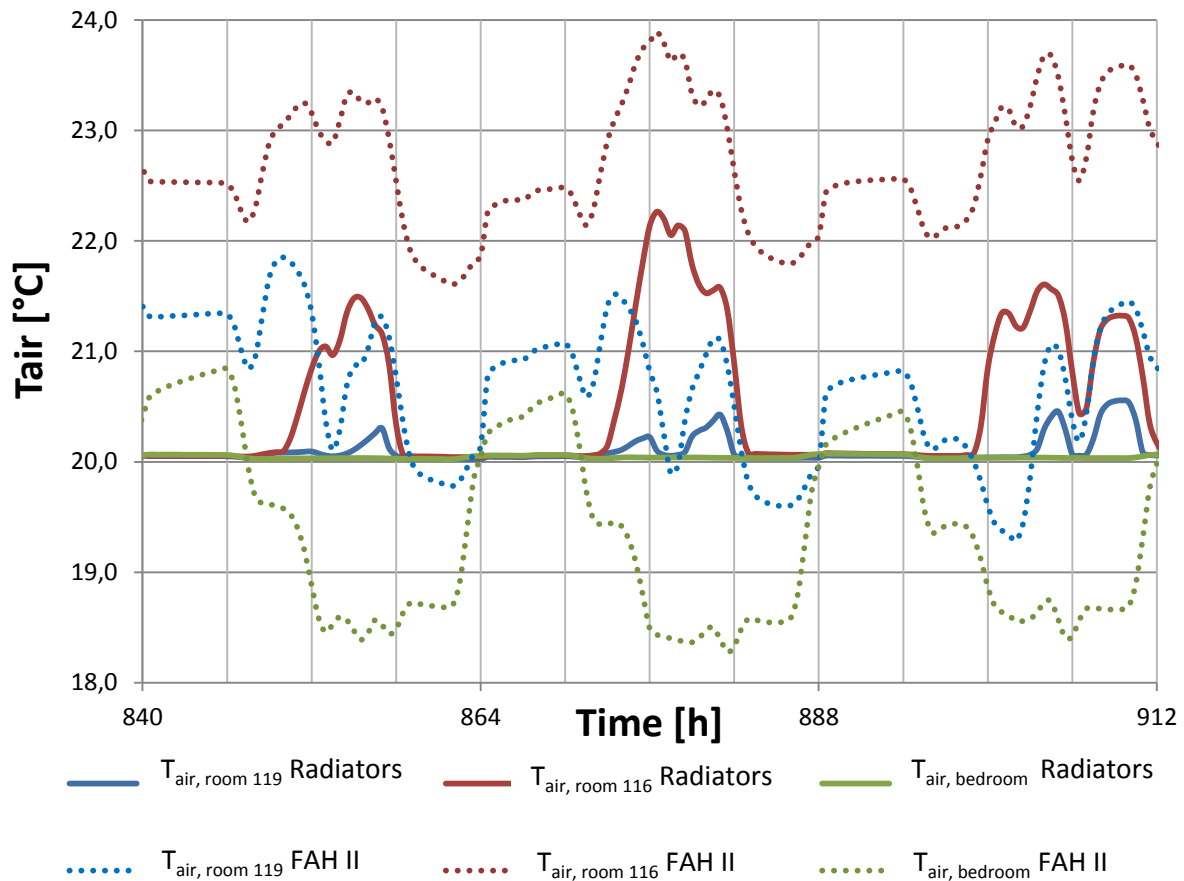

Annex X Final Report: Toward 4th Generation District Heating

Figure 5.3 Comparison of T_{air} in 3 rooms for radiator and FAH systems.

Conclusions

According to this case study and the assumptions introduced, a properly designed low-temperature FAH system is the system with the best cooling of the DH heat carrier, followed by radiators and FH. If priority is given to shaving the peak heat load to be supplied by the DH network, radiators are the optimal solution. The same can be concluded also from the perspective of thermal comfort. In this perspective, FAH is the worst option because it lacks the possibility of temperature control in individual rooms.

6 Low Temperature District Heating in Existing Buildings

6.1 Introduction

It is estimated that the EU will need an annual rate of 3% deep building energy renovation to achieve its 2020 and 2050 energy and environmental targets. According to the EU Energy Efficiency Directive adopted in 2012, 3% deep building renovation is only enforced for public buildings, which represent a small portion of the total building stock. The total building stock renovation rate is much lower. This means that most of the heating demand will continue come from existing buildings which were originally designed to operate with high/medium temperature DH. This poses a challenge for the future development of LTDH, i.e., while LTDH shows good potential to be applied to low-energy buildings, can it be widely implemented in the near future before large-scale deep building energy renovation has taken place? It is therefore important to examine the feasibility of applying LTDH to existing buildings through minimum renovation of the buildings and the DH network.

The following section reports a preliminary study to apply LTDH to existing buildings in Denmark [29][30]. The analysis deals with one of Denmark's largest single-family building complexes called Skjoldhøjparken, located at Tilst near Aarhus (Figure 6.1). The houses were built in the 1970s. They are typical of existing single-family houses in Denmark, half of which were built from 1960-70. The heating systems in these single-family houses were originally designed with radiators operating at the medium network supply/return/room temperatures of 80/40/20°C in winter and 70/40/20°C in summer.

6.2 Feasibility of implementing LTDH in existing buildings

The aim of the analysis is to study the feasibility of applying LTDH in existing buildings after necessary building renovation and network operation strategy change. The arguments for applying LTDH to existing buildings centre on the following aspects:

- The radiators in the existing buildings may be over-dimensioned because the original radiators were designed based on the outdoor design temperature without taking account of the thermal mass of the buildings.
- The radiator is normally placed below the whole width of the window to prevent cold air draught, which may cause additional over-dimensioning.
- After necessary refurbishment, such as substituting highly energy-efficient windows, adding more insulation on external wall and roof, installing heat recovery in mechanical ventilation, or enlarging radiator heat emission area, the building can be supplied with LTDH.
- During peak heating demand season, the network should be operated in a flexible mode and supply higher temperatures than usual.

Annex X Final Report: Toward 4th Generation District Heating

- For the DHW preparation, the traditional DHW storage tank needs to be replaced with a DHSU designed for low temperature operation. The IHEU substation should also be replaced with a more efficient HE designed for low temperature operation.
- To reduce the peak heating demand and downsize the DH network dimension, the IHEU unit should be replaced with a DHSU. For the entire network, it is important to reduce the SH peak power.



Figure 6.1 Typical 1970s single-family house at Langøvænget in Skjoldhøjparken

6.3 Case definition

The study case was a single-family detached house from 1972, with a built area of 115 m². The house had 9 rooms. The floor plan is shown in Figure 6.2. The insulation thicknesses for the external wall, the floor and roof were 100 mm, 90 mm and 100 mm respectively. The U values in the building envelope are listed in Table 6.1.

There was natural ventilation in the house through ducts in the bathroom, living room, kitchen, WC and via the opening of doors and windows. The air change rate was assumed to be 0.5 h⁻¹ in every room. The internal heating load of the house consisted of heat gain from electrical equipment, lighting and people. An internal heating load of 5 W/m² was assumed for each room.

The house was heated with radiators in every room except the hall, utility room and toilet. The bathroom had electric FH. The radiator heating power was calculated at DH supply/return temperatures of 70/40°C, and a room temperature of 20°C, except for the bathroom, which was maintained at 22°C. It was assumed that 70% of radiator heat addition to the air was due to convection and the remaining 30% was due to radiation. The number, the dimensions and the power of radiators in each room are listed in Radiators in existing building.

Table 6.1 *U-values of existing building*

Construction	U-value [W/m ² K]
External wall	0.31
Roof	0.33
Floor	0.4
Creep basement	0.42

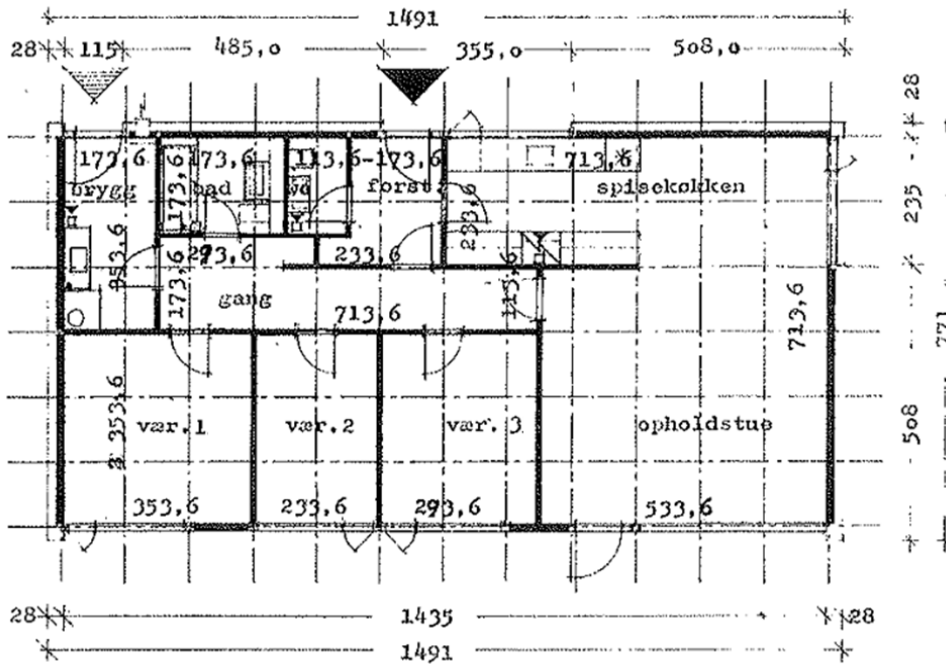

Figure 6.2 *Floor plan of the existing building*

Table 6.2 Radiators in existing building

Room	Window/door	No. of Radiators	Radiator Dimensions Height/Length [m/m]	Radiator power [W]
Bath		1	300/1000	165
Utility room	1 door	1	650/2200	858
Hall	1door	1	550/580	285
Corridor		1	550/580	285
Living room/kitchen	1 door, 3 windows at door	1	550/1900	1254
Room 1	1 window	1	650/2200	858
Room 2	1 window	1	650/2200	858
Room 3	1 window	1	650/2200	858
WC		1	300/1000	180

6.4 Analysis results

In the study, window renovation was chosen as the measure to reduce building heating demand because it was the easiest and cheapest solution. A window's typical life-time is 30 years so it was time to change the windows because the house was built in the 1970s. Two different window solutions were proposed and they are listed in Table 6.3 alongside the existing situation.

The applicability of introducing LTDH in existing buildings was studied using the building simulation program, BSim. The house was divided into 9 zones. The dynamic simulation was performed for the Danish Design Reference Year, with a minimum outdoor temperature of -21°C.

Table 6.3 *Window U-values for the different measures*

Case	Measures	Overall window U-value [W/m ² K]
1	No measures	2.5
2	New glazing, old frames	1.4
3	New low-energy windows (frame included)	0.9

Table 6.4 *Heating demand with the different measures*

Case	Peak power [kW] for -21°C	Energy demand for SH [MWh/year]	Temp. for SH	Flow rate [L/min]	Temp. for SH	Flow rate [L/min]	Temp. for SH	Flow rate [L/min]	Peak power [kW] for 0°C
			T _{out} = -21°C		T _{out} = 0°C		T _{out} = 0°C		
1	5.8	10.49	70/40/2 0	2.75	60/29/2 0	1.47	50/34/2 0	2.84	3.23
2	5.0	8.3	65/35/2 0	2.36	60/26/2 0	1.16	50/29/2 0	1.87	2.79
3	4.5	7.55	65/32/2 0	1.93	52/25/2 0	1.31	50/26/2 0	1.47	2.51

Table 6.4 shows the annual heating demand, peak power for SH and corresponding DH supply/return temperature, and the flow rate needed at the minimum outdoor temperature.

It can be seen that substituting new energy-efficient windows reduces the peak heating demand at the minimum outdoor temperature from 5.8 kW to 4.5 kW, a 28% reduction. This makes it possible to reduce the temperature of the SH supply/return flow down to 65/32°C. At an outdoor temperature of

Annex X Final Report: Toward 4th Generation District Heating

0°C, the network supply temperature can be further reduced to 52°C. A further reduction in the supply temperature down to 50°C is possible with a 12% flow rate increase. The conditions for LTDH at 50/25°C can be met after substituting new energy-efficient windows when the outdoor temperature is higher than 0°C.

If the windows have been replaced in the past with an overall U-value lower than 1.4 W/m²K the house can be supplied with LTDH without building refurbishment at the outdoor temperature above 0°C. According to the Design Reference Year (DRY), the duration for outdoor temperatures below 0°C is 1258 hours. The heating season for existing building is normally from 1st of September to 31st of May the next year, i.e., 6588 hours. This indicates that the DH plant should supply about 20% of the heating period with a higher supply temperature than defined for LTDH.

To maintain the same energy output from a radiator, it can either operate at higher supply and lower return temperature with a smaller flow rate or, alternatively, operate with a lower supply temperature and higher flow rate, sacrificing the lower return temperature.

Table 6.4 indicates that, at an outdoor temperature of 0°C, even without building refurbishment, the network can supply at 50°C, but with much higher flow rate and increased DH return temperature.

6.5 Conclusion

The preliminary study indicates that with necessary refurbishment, a building heating system which was originally designed for the medium temperature DH system can run with LTDH when the ambient temperature is above a certain limit. Below the temperature limit, a flexible DH operation strategy is suggested to gradually increase the DH supply temperature. The duration for such operation would be about 20% of the entire heating season.

It is arguable whether the network should be designed based on low-supply/high-return temperature plus high flow rate, or based on high-supply/low-return temperature plus low flow rate. In general, the question should be examined based on the individual DH network, type of heat source, and the in-house SH installations.

7 The District Heating Network

7.1 Overview

Figure 7.1 shows the hierarchy of a typical DH system. It consists of heat generation units, DH networks, substations and end-user installations. The heat can be generated in the large CHP plants, waste incineration plants, geothermal plants, large-scale HPs, or large-scale solar thermal plants, combined with peak and stand-by boilers. With the transition to RE, the fossil fuel in a CHP plant will be gradually phased out and replaced with renewable sources. To allow the CHP plant to operate at the optimal power-to-heat ratio, heat accumulators are installed for short-term storage to smooth the network heating demand and store excessive heat produced during low heating-demand periods.

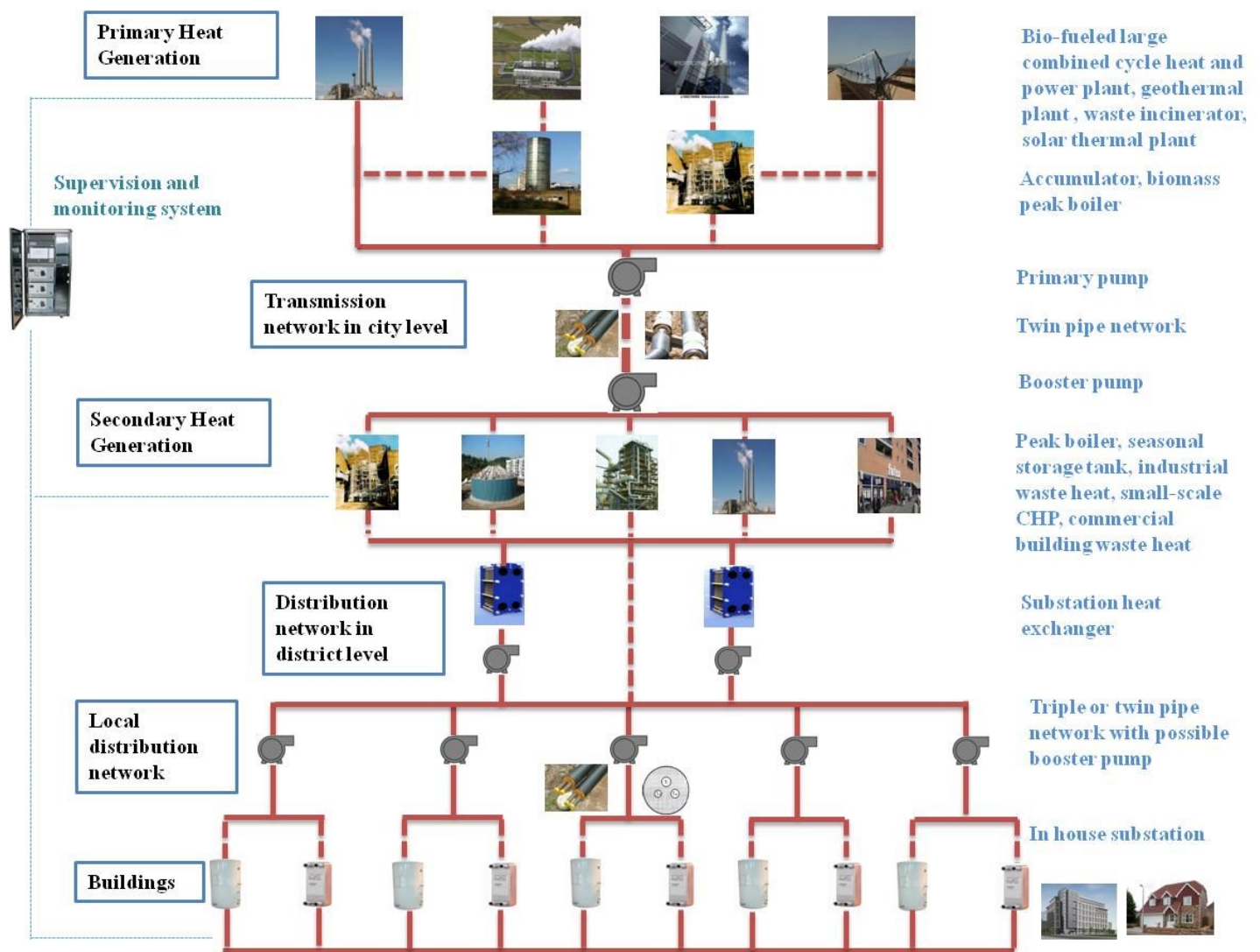

Figure 7.1 Hierarchy in a large DH network.

Annex X Final Report: Toward 4th Generation District Heating

In large DH networks, the primary heat sources are normally located at the edge of the city. The heating medium is transported from the heat source to the local substations by transmission pipelines and is further distributed to the end-users through the distribution pipelines.

Typical DH pipelines include single pipes and twin pipes. The application of triple pipes has been investigated, though there is as yet no commercially available triple pipe. Triple pipe is designed with two supply lines of small (but often differing) diameter and one return line of larger diameter. The smaller supply pipe is used in summer conditions when the heating demand is low, and the other supply pipe is used when the heating load becomes high. Pipe heat loss is minimized in this way. In addition, triple pipe allows the network to supply hot water at different temperature levels, which increases the network's flexibility to recover the waste heat at different temperature levels.

7.2 Design of Low-Temperature District Heating Networks

Once the basic input data, such as the geographical information of the area, the available sources of heat, and the layout of the pipes, has been determined, the consumer design heating load is estimated so that the pipe dimensions can be determined, and other network design parameters can be decided, such as the type of media pipe, the network operational temperature and pressure, etc.

In a branched type DH network, the pipe dimension is determined by the cumulative design heating loads downstream of the specific pipe segment. Individual consumers use the heat neither always at the maximum design value, nor at the same time as other consumers [31], so the consumer simultaneity effect is considered in the design phase to avoid over-dimensioning the DH pipes.

To size the pipe dimension, the traditional design method uses the specified maximum pressure loss gradient and/or the maximum velocity, both of which are derived from engineering experience. More advanced approaches size the pipe dimensions in accordance with the overall economically optimal solution based on the capital investment, including pump cost and network laying cost, and the operational cost, including the network heat loss cost, the pumping cost, the O&M cost, and the environmental cost[32][33].

7.2.1 Network Design in Low Heat Density Areas

The optimization method for low-energy DH network design is based on the consideration that the 4th generation DH networks will ensure greater cost-effectiveness if lower heat losses are guaranteed by means of reducing the media pipe sizes, because the consequent increase in the required pumping power is generally less significant in low-energy areas. A pipe dimensioning method is proposed with successive steps. First, the DH network is defined as a node and pipe data series determined by the geographical and the heat load data of the district. Secondly, the heat load of each pipe segment is determined separately on the basis of the cumulative size of the consumer load involved, with the simultaneity factor depending upon the consumer load. Next, an optimization method is used with the aim of minimizing the heat loss from the DH network by reducing the diameter of each pipe segment until the potential of the head lift provided by the pump station is utilized as much as possible. The optimization method achieves much greater energy saving than using rule-of-thumb pipe dimensioning

Annex X Final Report: Toward 4th Generation District Heating

methods, such as “maximum pressure gradient”, “maximum velocity”, or the combination of both. Exploiting the head lift provided by the main pump station to overcome the pressure loss occurring in each of the routes of the DH network does not cause a significant increase in pumping energy, yet leads to significant heat loss reduction from the DH network. This statement has been proved to be valid for maximum design static pressure values up to 10 bar, which is the design pressure limit for AluFlex twin pipes [33]. Nevertheless, exergetic assessment of annual exergy consumption has shown that pumping energy is still much lower than the overall heat loss from the DH network [18][34]. It should be noticed, however, that keeping the static pressure of the DH network low decreases the risk of water leakage and increases the durability of the equipment and pipes employed in the DH network.

7.2.2 Network Design in Existing Building Areas with Future Reduced Heat Demand

The existing heating infrastructures, consisting of traditional high- and medium-temperature DH networks and natural gas distribution networks, need periodic maintenance and replacement of equipment. The benefits of low-energy DH systems mean that the replacement/upgrade of existing heating infrastructures with low-energy DH systems and their harmonization with energy conservation activities in the building stock should be on the priority list of policy makers and energy planners. Transition processes from the current situation to low-temperature operation should be considered, because the dimensioning of LTDH systems for the current situation will be over-dimensioning for the future situation. An example of a possible implementation process was developed in [35] for the transformation of existing residential districts supplied by natural gas to energy-renovated buildings supplied by LTDH. The control philosophy of the DH operation envisaged the boosting of the supply temperature in periods with severe cold weather in order to satisfy requirements during the transition period from the present situation (high SH demand) and the future situation (low SH demand). So the optimization algorithm described in Section 7.2.1 was modified with additional functions, which allow an increase in the supply temperature in the present situation and also in the peak winter periods of the future situation. The hypothesis behind this is that most existing heating systems have been over-dimensioned, due to normal design practice, and that therefore most existing buildings that undergo energy retrofit could be supplied by LTDH without dramatically changing their original SH system. This statement needs to be investigated further.

7.2.3 Network Design in Extension Areas of Existing Networks

New and renovated buildings with low energy demand are ideal for implementing LTDH. However, due to their long lifetimes, the buildings with high energy demand that exist today will remain in a majority for a relatively long period. So the potential in applying LTDH networks to existing buildings is worth investigating. In fact, areas with low linear heat density which were originally excluded from the 3rd generation DH networks may be willing to connect to a LTDH network because of the economic savings to be made. During the transition, the 4th generation DH network can connect to the 3rd generation DH network, so that the upstream pipelines and civil works can be kept.

7.3 District Heating Pipes for Low-Temperature District Heating

Annex X Final Report: Toward 4th Generation District Heating

LTDH has the advantage that it can achieve much lower heat losses without dramatically increasing the amount of insulation. We can explain this with an example, in which we consider two pipe types: the first, a typical medium-size distribution steel twin pipe (DN65, insulation series 2), and the second, a typical plastic service pipe (Aluflex 16-16, insulation series 2). We compared the heat losses at normal operational temperatures (supply: 85°C, return: 45°C) and in low-temperature operation (supply: 55°C, return: 25°C). Calculations proved that, to achieve the same heat loss, the distribution pipe and the service pipe in the first case need, respectively, 3 and 11 times more insulation than in the second case. Current DH pipelines are based on the single-pipe system, where the supply/return water flows in separate media pipes with their own insulation, or on the twin-pipe system, where both pipes are placed in the same insulated casing, or on a mixture of both systems. More advanced concepts, such as triple pipes, double pipes with asymmetrical insulation, ESPEX (cross-linked polyethylene (PEX) media pipes with extruded polystyrene (EPS) insulation), are becoming commercially available. The application of plastic pipes to LTDH is promising with regard to durability, energy conservation and economy. As consequence of low average temperatures, long pipe lifetimes (70-100 years) can be predicted according to [36]. New pipe design configurations may make it possible to reduce the network heat loss still further. Asymmetrically insulated twin pipes, double pipes and triple pipes are promising innovative technologies that are being developed by means of computer-based heat transfer simulations.

This part of the report aims at providing scientific knowledge for the development of improved solutions for DH networks with focus on DH pipeline energy performance. First, we consider the analysis of heat loss in DH pipes whose design has been optimized for low-temperature applications. Next, we look at the transient heat transfer and temperature dynamics in DH service pipes, which are critical items in DH networks supplying energy-efficient areas. The objective is to describe models and tools for assessing the energy performance of optimal pipe geometries and system configurations. The models have been validated against experimental measurements in [37][38].

7.3.1 Pipe Design with Low Heat Losses

Table 7.1 lists the standards that describe the calculations for heat transfer in DH pipes and the thermal properties of pipe materials. The calculation of heat loss and insulation properties, such as thermal transmittance, U , and thermal conductivity, λ_i , is relatively simple for single pipes, where the geometry consists of concentric circles: formulas can be derived directly from Fourier's heat transfer theory. The geometry of twin pipes (see Figure 7.2) or, in general, any DH pipes with at least two media pipes embedded in the same insulation is more complex, and simple analytical calculations cannot be performed. The standard for flexible twin-pipe systems, EN 15632-1:2009, introduces definitions of radial thermal resistance, R_{TPS} , and of thermal conductivity, λ_{TPS} , but the standard basis for calculating both R_{TPS} and λ_{TPS} has been shown to be flawed, because the formulas are not dimensionally correct and, in the case of λ_{TPS} , not even accurate.

Annex X Final Report: Toward 4th Generation District Heating

Table 7.2 List of standards for the calculation and measurement of thermal properties and heat transfer in DH pipes.

	Parameter	Straight Pipes	Flexible Pipes
Single-Pipe System	λ_i	EN 253	EN 12667
	λ_{SPS}	-	EN 15632-1
	U	-	EN 15632-1
Twin-Pipe System	λ_i	EN 253	EN 12667
	λ_{TPS}	-	EN 15632-1
	U	EN 15698	-
	U_{TPS}	-	EN 15632-1

The use of pre-insulated DH twin pipes is predicted to prevail in the coming years, due to its improved thermal performance and the savings in civil works connected with laying the pipes in the ground.

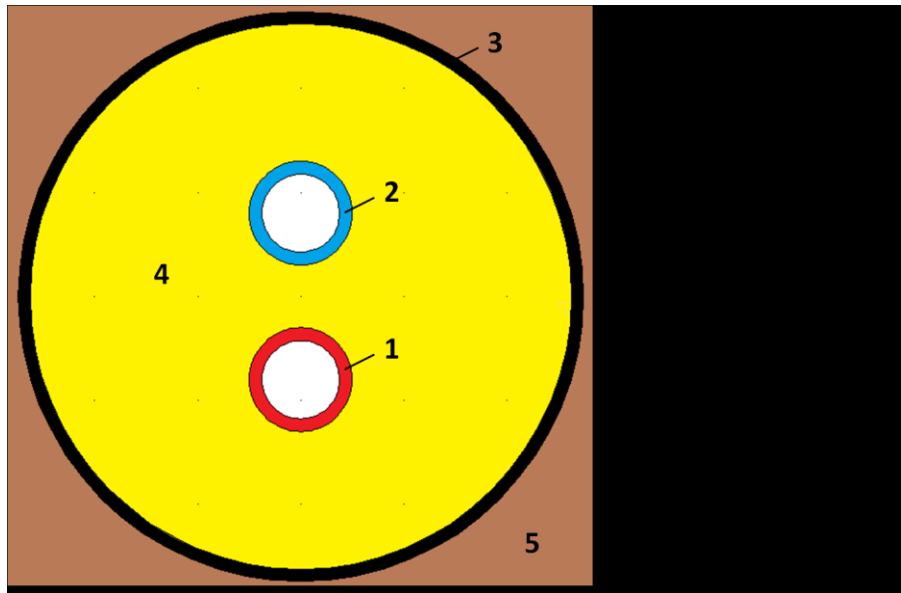

Figure 7.3 Geometry and materials of a flexible, pre-insulated, twin pipe. Example: Aluflex 20-20/110, cross-section x-y.

The standard EN 15632-1:2009 indicates that the thermal conductivity of the insulation material, λ_i , should be found by measurements in accordance with EN 12667:2001, which is based on measurements of samples of insulation material taken from pipe manufacturers. Since the thermal conductivity of a material depends on the temperature, it is necessary to define the function $\lambda_i = f(T)$, where T is the temperature of the insulation at a specific point, which in a cross section of the pipe in the plane x-y can be defined by its coordinates (x, y) (see Figure 7.3); this means that λ_i is not

Annex X Final Report: Toward 4th Generation District Heating

constant across the insulation domain, but varies from higher values, for example in the central zone of the pipe, between the two media pipes, and lower values, for example in the outer regions near the casing pipe. This approach was followed in the investigations reported below and is further explained in [4].

Asymmetrical insulation in twin pipes

The expression “asymmetrical insulation” means that the position of the media pipes in the insulation is such that the centre line deviation of the supply pipe is different from the centre line deviation of the return pipe. Results show that such asymmetrical insulation of twin pipes makes improvements possible (see Table 7.3). We proved that a better design leads to lower heat losses from the supply pipe (leading to a lower temperature drop); furthermore, the heat loss from the return pipe can be close to zero, maintaining isothermal conditions in the return line. If commercially available casing sizes are used, we suggest two design strategies depending on the size of the pipes (see Figure 7.4). For small pipe sizes (Aluflex: \leq DN 26, steel: \leq DN 50), the best design is to place the supply pipe in the centre of the casing, ensuring the best possible insulation for the supply pipe. This strategy also guarantees the lowest temperature drop in the supply line, which is a critical figure in low-temperature applications. The return pipe is placed at a vertical distance from the supply pipe, so that the total heat transfer from the return pipe boundaries is zero. The distance between the media pipes is not necessarily the same as in the symmetrical case. For larger sizes (Aluflex: \geq DN 26, steel: \geq DN 50), the best design is achieved by moving the media pipe layout “up” and at the same time retaining the same distance between the media pipes as in the symmetrical case. In fact, it is not possible to apply the first design concept for large media pipe sizes embedded in standard insulation casings, due to space restrictions.

Table 7.4 Comparison between asymmetrical and symmetrical insulation in twin pipes. The centre of the casing is the origin of the Cartesian system (x; y).

Pipe data		Coordinates (x; y)		Heat loss[W/m]			Asymm.-Symm [%]	
Size (DN)	Material	Supply [mm]	Return	Supply	Return	Total	Supply	Total
14		(0; 0)	(0; 27)	3.24	0.01	3.25	-7.6	2.0
16		(0; 0)	(0; 28)	3.56	-0.01	3.55	-5.1	1.1
20	Aluflex	(0; 0)	(0; 30)	4.16	-0.04	4.12	-4.2	-0.3
26		(0; 0)	(0; 36)	4.67	0.00	4.67	-5.1	1.9
32		(0; -16)	(0; 28)	5.54	0.00	5.54	-5.8	-2.5
50	Steel	(0; -25)	(0; 55)	5.69	-0.03	5.66	-7.7	-2.4
65		(0; -36)	(0; 60)	6.70	-0.02	6.68	-7.8	-3.2

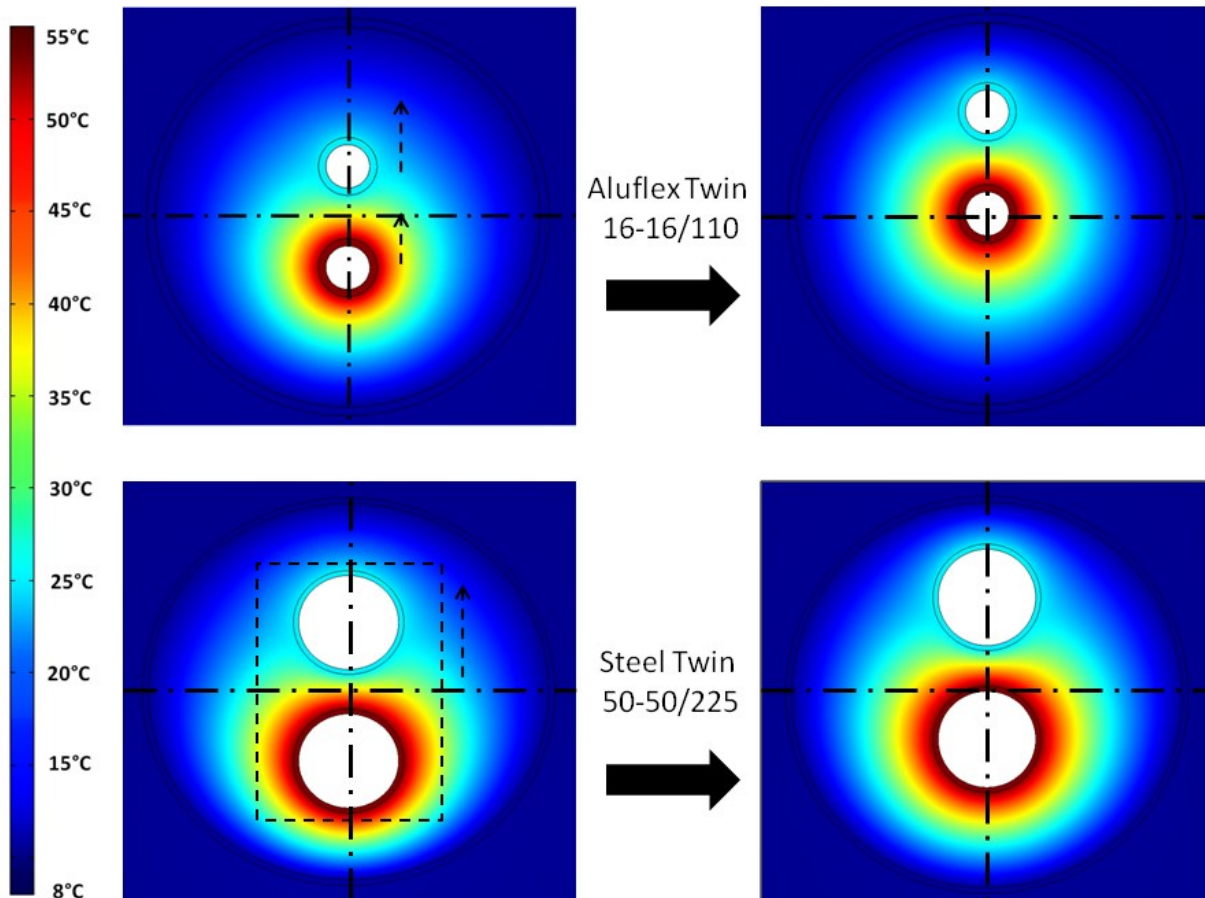

Figure 7.5 Proposed modification in DH pipe design. Top: Aluflex Twin 16-16/110. Bottom: Steel Twin 50-50/225.

Triple Service Pipes

We assessed the development of an optimized triple-pipe solution for low-temperature applications using detailed heat transfer models. In this research, focus was given to choosing media pipe diameters as small as possible, in accordance with LTDH principles. DH manufacturers state that it is not reasonable to consider media pipes whose internal diameters are smaller than 10 mm, due to risk of malfunctioning. So, in the following, the triple-pipe geometry is based on modifications of the 14-14/110 twin-pipe design described in [15]. Four geometrical variations were considered, and the Cartesian coordinates describing the position of media pipes inside the casing are listed in Table 7.5. Starting from the standard configuration (geometryA), we assessed three other possible configurations, in which the main supply pipe is moved step by step towards the centre of the casing pipe and thus to the core of the insulation, while the recirculation pipe is first put in a position between the supply pipe and the return pipe (geometries B and C) and then below the supply pipe (geometry D).

Annex X Final Report: Toward 4th Generation District Heating

Table 7.6 Position of media pipes inside the casing for four triple-pipe geometries, type Aluflex 14-14-20/110.

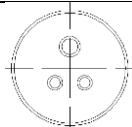
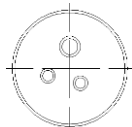
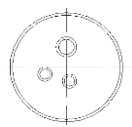
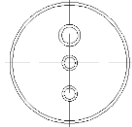
Geometry	Coordinates (x, y) [mm]		
	Pipe 1 (Supply)	Pipe 2 (Return)	Pipe 3 (Supply/Recirculation)
A		(14;-14) (0;20.5)	(-14;-14)
B		(10;-14) (0;20.5)	(-21;-7)
C		(3;-14) (0;20.5)	(-21;-7)
D		(0; 0) (0;25)	(0;-28)

The results of the FEM simulations for the four geometries and the three possible operational modes (I, II, II) are listed in Table 7.7:

Mode I, *DHW tapping*: supply pipe, return pipe and second supply pipe are active.

Mode II, *supply-to-supply recirculation*: supply pipe and recirculation pipe are active; return pipe is not active.

Mode III, *SH demand*, supply pipe and return pipe are active; recirculation pipe is not active.

Since Mode II occurs when there is no demand for space heating and therefore outside the heating season, simulations were also carried out for a more realistic ground temperature (14°C) for that period in Danish weather conditions (see Table 7.8). This also gives insight into the effect of ground temperature throughout the year.

Annex X Final Report: Toward 4th Generation District Heating

Table 7.9 Steady-state heat losses of triple pipes type Aluflex 14-14-20/110 for 4 geometries and operational modes I, II, III. Temperatures: supply/recirculation/return/ground: 55/55/25/8°C.

Operational Mode	Geometry	Heat loss [W/m]			
		Pipe 1 (Sup.)	Pipe 2 (Ret.)	Pipe 3 (Circ.)	Total
I (DHW tapping)	A	2.67	-0.08	2.67	5.30
	B	2.91	-0.29	2.75	5.38
	C	2.52	-0.22	2.74	5.06
	D	2.46	0.05	2.74	5.24
II (supply-to-supply recirculation)	A	2.67	/	2.67	5.34
	B	2.69	/	2.85	5.55
	C	2.48	/	2.70	5.18
	D	2.49	/	2.75	5.25
III (space heating)	A	3.46	0.48	/	3.95
	B	3.39	0.43	/	3.83
	C	3.41	0.35	/	3.76
	D	3.53	-0.01	/	3.53

Table 7.10 Steady-state heat losses of triple pipes type Aluflex 14-14-20/110 for 4 geometries and operational mode II. Temperatures: supply/recirculation/return/ground: 55/55/25/14°C.

Operational Mode	Geometry	Heat loss [W/m]			
		Pipe 1 (Sup.)	Pipe 2 (Ret.)	Pipe 3 (Circ.)	Total
II (supply-to-supply recirculation)	A	2.35	/	2.35	4.70
	B	2.37	/	2.51	4.88
	C	2.39	/	2.63	5.02
	D	2.20	/	2.42	4.62

We concluded that there is no “absolute best” design for the service triple pipe: it depends on the operational mode that is chosen as critical. The results in Table 7.9 and Table 7.11 show that geometry C gives the lowest total heat loss for operational modes I and II, while geometry D has the best thermal performance for operational mode III and for operational mode II, if a ground temperature of 14°C is considered. It should be emphasized that geometry D shows no heating of return water in

Annex X Final Report: Toward 4th Generation District Heating

operational mode III, which is a desirable situation; however, it has a slightly higher heat loss from the supply pipe than the other geometries. Moreover, the temperature drop in the supply pipe to the DHW HE is critical in low-temperature applications, so that it is strongly recommended that the heat loss from this media pipe should be minimized. Mode III is the most likely during the heating season, and mode II is the most likely outside the heating season, while operational mode I usually occurs for less than 1 h/day. Considering all this, the conclusion is that geometry D is to be preferred.

Double-Pipe Networks

A double pipe consists of a pair of media pipes of dissimilar size, insulated in the same casing. This is a further development of the twin-pipe concept. A sketch of a possible application of the double-pipe concept is shown in Figure 7.6. Such applications make it possible to reduce network heat loss when operating during low heating-load periods. The space heating demand in summer is low, except for the energy requirement in bathroom heating. The design in Figure 7.7 is based on the fact that the supply line also acts as the recirculation line during such periods of time; this means that no bypass is needed at the critical consumers and the exergy loss from sending supply water directly back into the return line is avoided. Furthermore, the water flow in the return line has the same direction as in the supply line (clockwise in the example), so that the smallest size for the return pipes is expected to be encased with the biggest size for the supply size, and vice versa. This results in lower local pressure differences between supply and return lines and savings in operational costs due to lower heat losses. This is shown in Table 7.12 by means of two examples: the first one refers to a small-to-medium size distribution network, the second one to a larger network capable of supplying four times more energy than the smaller one. We considered an optimal positioning of the media pipes in the double-pipe casing, and therefore asymmetrical insulation. The same total amount of insulation is used in both the twin-pipe-based distribution network and the double-pipe-based one, so that the investment costs are equal in the two cases.

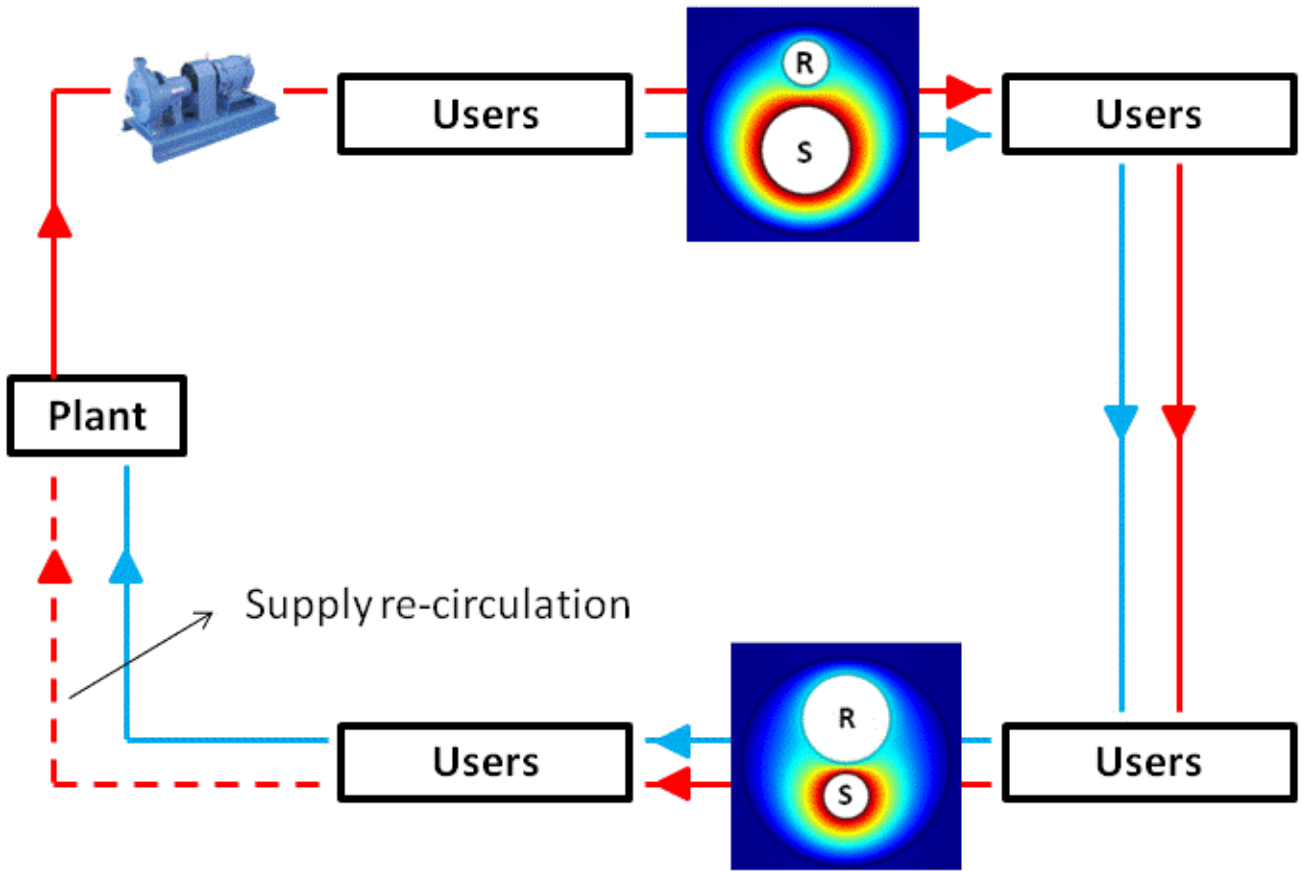

Figure 7.8 Sketch of the possible application of the double-pipe concept in a simple district heating network.

Annex X Final Report: Toward 4th Generation District Heating

Table 7.13 Left: comparison between a distribution network based on twin pipes (DN40-40 and DN80-80) with a distribution network based on double pipes (DN40-80 and DN80-40). Right: comparison between a distribution network based on twin pipes (DN100-100 and DN200-200) with a distribution network based on double pipes (DN100-200 and DN200-100). Supply/return/ground temperatures: 55/25/8°C.

Heat loss [W/m]						Heat loss [W/m]					
Size (DN)	Sup.	Ret.	Tot.	Total	[%]	Size (DN)	Sup.	Ret.	Tot.	Total	[%]
0-40	-6.2	0.0	-6.2	Twin		100-100	-7.8	-0.6	-8.4	Twin	
80-80	-7.7	0.1	-7.6	-13.8		200-200	-8.9	0.2	-8.7	-17.1	
				6.1						11.8	
40-80	-5.6	0.1	-5.6	Double		100-200	-6.4	0.1	-6.4	Double	
80-40	-7.4	0.1	-7.4	-12.9		200-100	-8.7	0.0	-7.4	-12.9	

The results show that the heat loss can be reduced by 6% by using double pipes instead of twin pipes for the small to medium-size distribution network. Even higher energy savings (around 12%) are possible in the case of the large distribution network.

7.4 Bypass Strategies in Low-Temperature District Heating Systems

The heat demand in buildings decreases dramatically in the non-heating season because the final users need heat only for DHW use. The demand for DHW is discontinuous and generally totals less than 1 h/day in typical single-family homes. The lack of heating load would cause the undesirable cooling of the network to temperatures that would become insufficient to ensure the prompt provision of heat when DHW preparation is required, if proper control strategies are not implemented. This problem is particularly relevant in LTDH systems with an already very low supply temperature.

To overcome the excessive temperature drop along the supply pipe due to reduced flow rate, the solution is to install bypass systems at the critical users in the network. Bypasses are normally controlled by a thermostat which is defined by the set-point temperature, $T_{bypass, set}$ and the amplitude of its “deadband”, ΔT_{DB} , which also defines:

– the “top temperature”: $T_{bypass, top} = T_{bypass, set} + \Delta T_{DB}/2$ (6.1)

– the “bottom temperature”: $T_{bypass, bottom} = T_{bypass, set} - \Delta T_{DB}/2$. (6.2)

Annex X Final Report: Toward 4th Generation District Heating

The bypass control therefore ensures that the network supply temperature is kept within the range of operation set by the deadband.

The bypass water returns directly back to the network without passing through the heating elements inside the building, so the network return temperature will increase, which will increase the network heat loss and possibly decrease the heating plant efficiency. For low-energy buildings, the total duration of the SH periods is generally shorter than in traditional buildings, so optimal bypass operation strategies become even more important. There are two different ways to avoid the direct mixing of thermal bypass water with the return water: “maximum cooling” or “minimum cooling” of the bypass water. In the first principle, the bypass water is further cooled by exploiting additional heating load, such as bathroom FH in summer as in what is known as the 'Comfort Bathroom (CB)' concept. In the second principle, the bypass water is looped back to the main supply line through a third pipeline, as shown in Figure 7.9. The premise here is that the temperature drop along the loop is negligible.

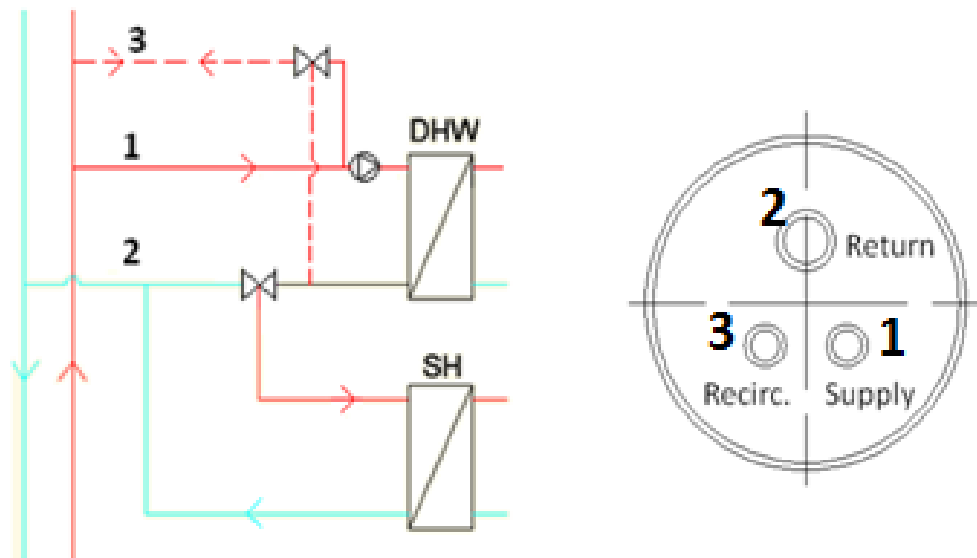

Figure 7.9 Schematic for bypass water back to the third pipeline

Annex X Final Report: Toward 4th Generation District Heating

To simulate the bypass operation, two basic assumptions can be made. The first one is the ideal situation where a constant and continuous bypass flow is kept through the service pipe which will maintain $T_{bypass, set}$ at the service pipe outlet, where the bypass control is assumed to be located. The second one is the case of a perfectly “intermittent” bypass operation: the bypass during the intermittent operating mode is modelled as an ideal control that acts like an on/off switch. When the temperature at the outlet of the service pipe reaches a specific value, $T_{bypass, top}$, the bypass flow instantaneously stops. The pipe is now in the ‘stand-by’ mode, meaning that there is no flow in the media pipe and the water gradually cools down. After a certain time, the temperature at the service pipe outlet has decreased to the value of $T_{bypass, bottom}$, and the bypass flow instantaneously starts again and operates in the “bypass mode”. In this way, the bypass operation is periodical.

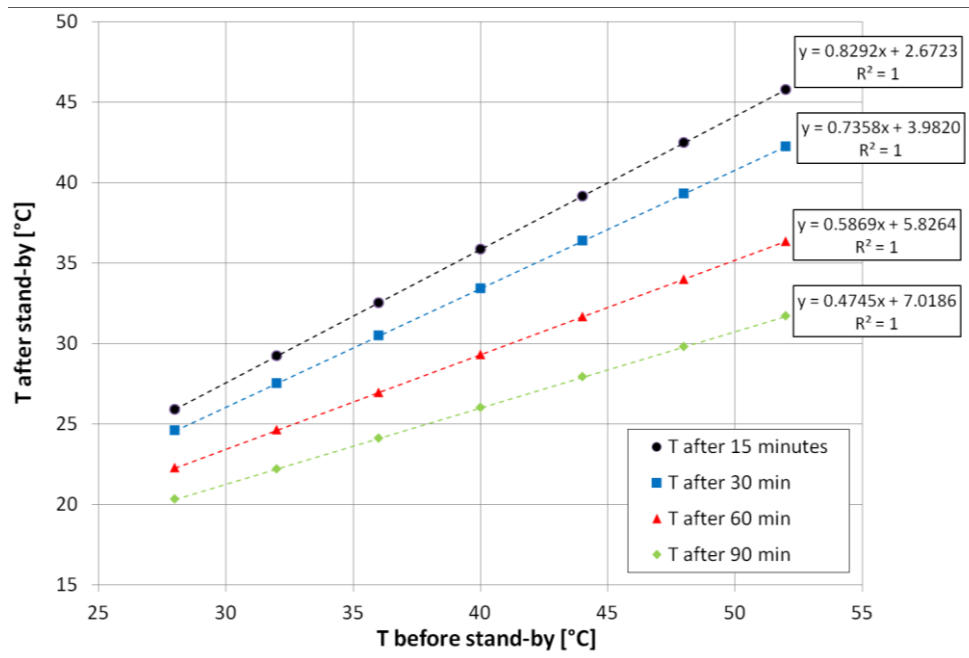

Figure 7.10 Examples of cooling-off curves for the heat carrier, derived by 2-D transient heat transfer simulations in COMSOL Multiphysics. Service pipe: Alx. 20-20/110. At $t=0$ s: $T_{soil} = 8^{\circ}\text{C}$, $T_{PUR} = 15^{\circ}\text{C}$, $T_{return} = 25^{\circ}\text{C}$.

The bypass operation was simulated for a 10-metre-long service pipe Aluflex 20-20/110. This is a typical product for connections in single-family buildings equipped with a DH HE unit. $T_{bypass, top}$ was set to 40°C and $T_{bypass, bottom}$ was set equal to the temperature at the service pipe outlet after 15 minutes of stand-by period. The cooling of the water during the ‘stand-by’ period was evaluated by regression curves derived by 2-D transient heat transfer simulations in COMSOL Multiphysics, as shown in Figure 7.10. For the intermittent bypass case, various water flows were applied. Figure 7.11 shows a case for $Re=2100$. The left-hand figure shows the pipe outlet temperature variation during the bypass

Annex X Final Report: Toward 4th Generation District Heating

period. The right-hand figure shows the temperature distribution along the pipe immediately after the bypass flow has stopped (red curve) and immediately before the bypass starts (blue curve).

a) Reynolds number, $Re = 2100$

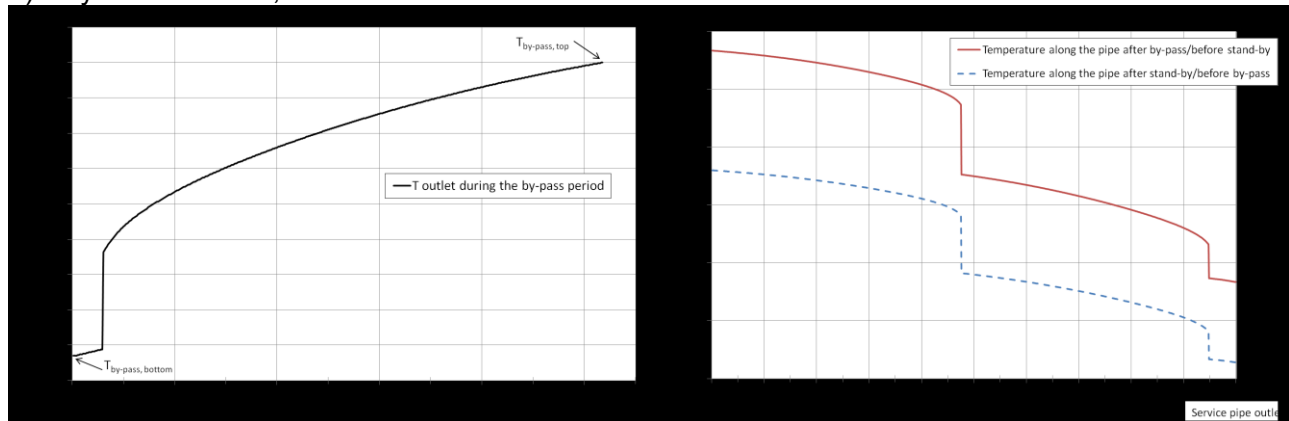

Figure 7.11 Intermittent bypass operation. Left: bypass period, outlet temperature vs. time. Right: stand-by period, heat carrier temperature vs. the longitudinal coordinate. Bypass flow: a) 0.96 kg/min;

Comparison between continuous bypass and intermittent bypass shows that the intermittent bypass operation circulates approximately 50% more water resulting in 10-35% greater heat loss than the continuous bypass. Based on this, it would be beneficial to replace the traditional thermostatic bypass using intermittent operation with a solution that keeps the flow constant, such as using a small needle valve.

7.5 Low-Temperature Technical Solutions: the “Comfort bathroom”

As one of the energy-efficient bypass solutions, the Comfort Bathroom concept is introduced in this chapter[39]. The Comfort Bathroom is a concept to redirect insufficiently cooled DH water from the external bypass of an in-house substation to bathroom FH during the non-heating period. The idea of the 'comfort bathroom' is to supply continuous bypass water to the FH system in the bathroom, thus maximally cooling the bypass temperature before enters the return pipeline. At the same time, the Comfort Bathroom also improves consumer thermal comfort during the non-heating season.

7.5.1 Technical Solutions for CB Concept

The CB concept can be achieved with an FH loop controlled using a TRV (thermostatic valve controlled by operative temperature) or an FJVR valve (thermostatic valve controlled by temperature of fluid). It can be used in both direct connection systems and indirect connection systems. The supply temperature to FH can be controlled using a mixing loop or not controlled.

Annex X Final Report: Toward 4th Generation District Heating

Figure 7.9 shows various technical solutions for the CB concept. Each figure is explained briefly below:

a). Figure 7.9 a is the original SH connection scheme which was used in the LTDH pilot project at Lystrup, Denmark. It is a direct connection system without a mixing loop, and supplies 50°C during moderate outdoor temperatures. The FH is controlled by an FJVR valve mounted on the return loop. The DHW substation is kept warm using an external bypass with a set-point temperature of 35°C.

b). Figure 7.9 b shows the CB solution that replaces the external bypass with a needle valve installed in parallel to the FJVR valve at the FH return loop. The needle valve is positioned in the loop of the differential pressure controller, so that the flow remains constant to avoid the influence of pressure oscillations in the DH network. During the period when the bypass flow through the needle valve is not enough to heat the bathroom, additional flow can pass through the originally installed FJVR. The advantage of this solution is the simple and cheap installation of the needle valve in the substation (i.e. no need to take any action in the FH loop). The drawback of the solution is the lack of an “automatic stop” of the bypass flow when the supply temperature is above the set-point temperature. The needle valve solution can also be used with a traditional TRV valve by installing the needle valve in parallel with the TRV valve.

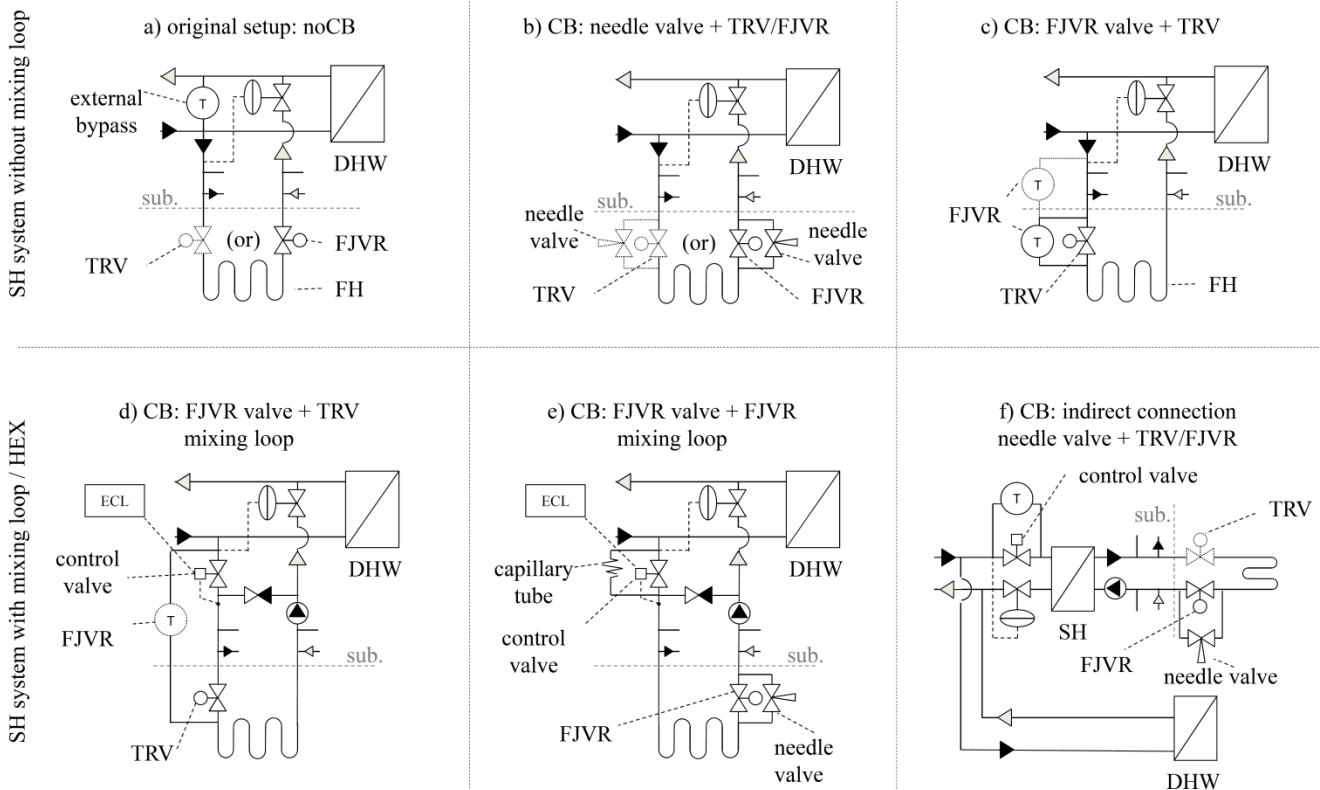

Figure 7.9: Technical solutions for CB implementation. Direct SH system without mixing loop: a) reference case with traditional external bypass; b) CB realized with a needle valve; c) CB realized with a TRV valve. Direct SH system with mixing loop: d) CB realized with a TRV valve; e) CB realized with a needle valve. Indirect SH system: f) CB realized with a needle valve

Annex X Final Report: Toward 4th Generation District Heating

c). Figure 7.9 c shows the alternative CB solution that replaces the needle valve with an FJVR valve installed in parallel to the TRV valve. This solution can prevent the supply of bypass water with a temperature above the bypass set-point temperature. The FJVR valve acts as an external bypass valve to the TRV valve to redirect a small DH flow to the bathroom FH. The valve is closed when the water temperature rises above the bypass set-point. This situation occurs in both the heating season and the non-heating season after each DHW tapping. The disadvantage of this solution is that it will eliminate the advantages with regard to reduced flow/heat loss achieved by the needle valve.

d). Figures 7.9 d-f show the implementations of the CB concept with controlled FH supply temperature. Figure 7.9 d shows a direct connection system with a mixing loop. The CB concept is realized by “bypassing” the TRV valve with an FJVR valve. If the FH loop is controlled by an FJVR valve, the main SH control valve is bypassed with a needle valve, as shown in Figure 7.9 e. Figure 7.9: f shows an indirect connection system with the CB concept realized by bypassing the main SH control valve with an FJVR valve, but the main SH control valve then needs to be moved to come before the SH HEX. The change needed on the secondary side (the in-house SH system) is the installation of a needle valve in parallel with the FJVR or TRV valve. In this solution, the SH HEX is kept continuously at bypass standby temperature, but this is not seen as a problem, because the HEX is expected to be insulated.

7.5.2 Modelling of CB CONCEPT

The CB was modelled in a 157 m² single-family house using the building simulation program, IDA-ICE 4.2. The house has two bathrooms (8.3 and 4.3 m²) and the CB concept was implemented in both of them. The typical building design criteria include:

- The building is low-energy class 2015 in accordance with the Danish Building Regulation 2010 (BR10). The total energy demand for SH, DHW heating and the operation of HVAC systems is below 37 kWh/(m².y) after accounting for primary energy factors.
- The ventilation system is designed to supply 216 m³/h, and the heat recovery has 85% efficiency.
- The windows are shaded by a 0.5 m roof-overhang and external blinds (g value of 0.14), which are drawn when the solar irradiation on the window increases above 300 W/m².
- The internal heat gain was assumed to be a constant 5 W/m².
- The operative temperature in the house in all rooms is always below 26°C. Venting by opening of the windows starts when the air temperature in the room rises above 24°C and stops when the air temperature drops below 22°C.

In the CB model, a more realistic DHW draw-off profile was assumed, with 5-minute DHW tapping every 3 hours between 6:00-24:00. During the non-heating season, the DH supply temperature to the substation is 50°C for 5 minutes during DHW tapping and then drops linearly for 45 minutes to 35°C.

Annex X Final Report: Toward 4th Generation District Heating

In accordance with the possible technical solutions for FH, six cases were studied with three different bypass flow rates (1.77 kg/h, 4.68 kg/h, and 9.36 kg/h) to represent different network locations:

Fejl! Henvisningskilde ikke fundet. summarizes the performance of all the cases investigated for the non-heating period, i.e. from 15 April to 15 November in the three different locations in the DH network. These are defined as locations where the DH water at the beginning of the service pipe has a temperature of 50°C, 40°C and 37.3°C, respectively. The average return temperature reflects only the performance of the external bypass/CB and does not take account of the effect of DHW tapping, because the DHW tapping accounts for only 3% of the day (40 minutes).

Table 7.7: Comparison of simulated cases for non-heating period 15/4 – 15/11, i.e. 5160 hours.

case #	nominal bypass flow [kg/h]	T_{op} avg	T_{flo} or avg	T_{ret} avg	bypassed volume [m ³]	average heat output from FH [W]	energy delivered by SP [kWh]	energy used in FH [kWh]	heat demand incl. FH [kWh]	increase of heat demand [%]	CB cost for customer [DKK]	bypass cost for DH company [DKK]	
		[°C]	[°C]	[°C]									
location 1	1	1.77	23.5	24.4	25.2	24.3	97	1212	500	2945	17%	325	-49
	2	2.6	22.4	22.4	35.0	9.7	0	435	0	2352	0%	0	110
	3	1.77	23.0	23.0	23.3	9.1	32	430	165	2518	7%	107	-3
	4	2.6	22.7	23.0	23.2	9.7	29	435	150	2502	6%	98	12
	5	1.77	22.9	22.9	22.9	6.9	22	322	116	2467	5%	75	3
location 2	1	4.68	23.5	24.4	25.2	32.6	96	1454	496	2943	17%	322	-199
	2	7.1	22.4	22.4	35.0	25.7	0	1089	0	2348	0%	0	97
	3	4.68	23.2	23.8	24.4	24.1	72	1069	373	2721	14%	242	-151
	4	7.1	23.2	23.7	24.3	25.7	64	1089	333	2681	12%	216	-119
	5	4.68	23.1	23.3	23.8	16.8	46	727	236	2586	9%	153	-90
	6	7.1	23.2	23.7	24.4	25.7	63	1089	323	2697	12%	210	-119
location 3	2	14.0	22.4	22.4	35.0	50.9	0	2126	0	2348	0%	0	0
	3	9.36	23.5	24.8	25.8	48.3	127	2110	655	2996	22%	425	-425
	4	14.0	23.4	24.6	25.6	50.9	111	2126	571	2919	20%	371	-371
	5	9.36	23.3	24.1	24.8	34.0	81	1428	418	2766	15%	272	-272

Annex X Final Report: Toward 4th Generation District Heating

- Case 1 represents the reference case that runs FH for the entire year, but with a traditional external bypass. The FH loops in the bathrooms are equipped with an FJVR valve at the return pipe, controlling the mass flow to keep the return water from each loop at the set-point temperature of 25°C. The traditional external bypass is operated when the temperature in the inlet of substation drops below 35°C. On the other hand, the flow needed in both bathrooms during the non-heating period can be higher than the minimal bypass flow, resulting in temperatures above 35°C at the inlet of the substation.

This solution will sometimes result in higher flow than needed to keep the service pipe ready for use in the non-heating period. On the other hand, for some periods, the flow rate required by FH in both bathrooms will be not high enough to keep the inlet of the substation at the desired temperature, and it will activate the traditional external bypass anyway. This solution means the customer will get higher T_{op} and T_{floor} but will also pay for a 17% increase in heat demand compared to the reference case without FH during the non-heating period. For the DH company, this solution means reduced cost for bypass operation⁵.

- Case 2 represents another reference case. The substation is equipped with the traditional external bypass but no heating demand in the bathrooms during the non-heating period. This case is the traditional external bypass solution realized with an FJVR valve, but without redirecting the bypassed water to the CB. This results in the same bypassed volume as Case 4, which uses CB concept realized with an FJVR valve, but with an increased average return temperature of 35°C, which means greater heat loss from the DH network. This solution has no external SH cost in summer for the consumer, but the consumer has a colder floor in the bathroom. On the other hand, this solution is the most expensive one for the DH company due to the high network heat loss.
- Case 3 represents the CB concept with the needle valve installed in parallel to the TRV or FJVR valve. Flow through the needle valve is stopped during a heating period. Case 4 represents an improved CB solution in which the needle valve is replaced with an FJVR valve installed in parallel with the TRV valve. The bypass flow is automatically shut off when the DH supply temperature exceeds the set-point temperature. According to the simulation, the thermal performance (including both floor temperature and the DH return temperature) is similar whether the FJVR is considered as in intermittent operation or as in continuous operation. So the FJVR valve was modelled as continuous flow, controlled by a deadband of 3°C.

⁵The last column in **Fejl! Henvisningskilde ikke fundet.** represents the running costs for the DH company for bypass operation in the 10 m long service pipe during the non-heating season. The cost is calculated as the cost of heat lost in the service pipe during bypass operation minus the heat used in CB, which is paid for by the customer. The cost calculation takes into account the different temperatures at the beginning of the service pipe for different locations in DH network, namely 50°C, 40°C and 37.3°C.

Annex X Final Report: Toward 4th Generation District Heating

At the same location, the two solutions are comparable from the perspective of T_{op} , T_{floor} and the weighted average return temperature of bypassed water T_{ret} . In all three locations investigated, the FJVR valve results in an increase of roughly 6% in water volume bypassed during the non-heating period compared with the needle valve solution.

Although the CB realized with an FJVR valve results in a slightly higher volume of bypassed water than with a needle valve, the average supply temperature is lower (because the bypass is stopped if T_{sup} is over 35°C), which means less heat is transferred to the bathroom floor heating making the FJVR solution cheaper for the customer. The difference in thermal environment is minimal. On the other hand, CB realized with a needle valve will be a more beneficial solution for the DH company because the customer will be paying for more heat. However, it can be concluded that CB realized with an FJVR valve is better because, in comparison with the needle valve, the adjustment of an FJVR valve is very simple (adjustment of the desired temperature, not the flow rate), the valve automatically changes the bypass flow needed based on the actual conditions in the DH network, and CB is shut down automatically during a heating period.

- Case 5 represents a similar case to Case 4, but the FJVR valve is modelled without a deadband. This solution can be realized using an electronic step valve controlled by a temperature sensor.

Further saving potential can be seen in the application of an electronically controlled step valve with a reduced deadband. Such a solution will result in a reduced total bypassed volume and therefore lower running costs to keep the DH network ready for use. The volume of bypassed water will be reduced by roughly 30% compared to using an FJVR with a 3°C deadband.

- Case 6 represents the CB concept in the indirect SH system or in the direct SH system with a mixing loop. The temperature of the water supplied to the SH system during a heating season is controlled by a P-controller measuring the operative temperature in the bathroom and adjusting the supply temperature proportionally in a range from 21 to 29°C. The supply temperature to the CB loop during a non-heating period is the result of mixing the bypass flow required by the location of the building in the DH network with the flow returning from the CB loop. This solution has similar results to the CB realized with an FJVR valve in case 4.

7.5.3 CONCLUSIONS

The conclusions drawn for the CB concept study are:

- The CB improves the thermal comfort (sensation of warm floor) in the bathroom with an increase in the average floor temperature of 0.6–2.2°C. Depending on the location in the DH network, the temperature of the bypassed water is reduced from 35°C in the traditional external

Annex X Final Report: Toward 4th Generation District Heating

bypass solution to 23.2–25.6°C. This will ensure the proper cooling of the DH water and thus reduce network heat loss and enhance the energy-efficiency at the heating plant.

- The flow of redirected bypassed water can be controlled either by a needle valve providing continuous flow or by a thermostatic FJVR valve with a 3°C deadband resulting in a nominal flow rate 50% higher than with a needle valve. The two solutions are comparable from the perspective of T_{op} , T_{floor} and the weighted average return temperature of bypassed water T_{ret} . The solution with an FJVR valve is to be preferred because it does not need precise adjustment of the bypass flow and reacts instantaneously to changes in the supply temperature of DH water.
- The CB concept can be further improved by removing the deadband by using an electronic step valve control. This solution combines the advantages of needle and traditional FJVR valves, i.e. bypassing only the small flow necessary to keep the service pipe warm. This would save roughly 30% of the bypassed volume in comparison to using a needle valve and further decrease the average return temperature by 0.3-0.8°C depending on the location in the network.
- Using the bypass water for bathroom FH is a cost-effective solution for the DH utilities, the end-users, and society as a whole. The utilities can earn money supplying heat that otherwise would be wasted in distribution heat losses, and they also benefit from lower return temperatures. End-users can increase the comfort standard in their houses in an economical way. And society as a whole would benefit from the opportunity to include a larger share of low-grade heat and renewable energy in the heating system, which would decrease greenhouse gas emissions and contribute to the country's energy security.

8 Heat Sources

8.1 Renewable Energy Based Energy Conversion Systems

CHP plants produce high-exergy electricity simultaneously with heat at an overall plant efficiency that can be greater than 90%. The reduction in building energy demand means that electricity demand will increase its share of the total energy demand. Meanwhile, electricity market deregulation stimulates the generation of more power in CHP plants. With the same overall plant efficiency, it is also an energy-efficient way to produce high exergy-value electricity. This means that CHP plants should be designed with high operational flexibility and a high power-to-heat ratio. The use of LTDH will increase CHP plant energy conversion efficiency and power generation capacity.

Biomass in the form of wood chips and wood pellets are the alternative fuel to replace fossil fuel in the CHP plants. However, the use of biomass implies a number of potential conflicts due to many different demands and expectations for future biomass exploitation. Increasing the role of biomass as a primary source of energy generation (electricity and heat) requires land otherwise allocated to food crop production to be converted to energy crop production, potentially reducing food and feed production. All crop residues must be harvested, potentially reducing the carbon pool in soils. Moreover, if biomass in a future carbon-neutral society also has to cover the production of materials currently based on petro-chemical products or be converted to fuel for the transportation sector, even more pressure will be put on the biomass sector. One way to reduce the potential conflict is to reduce the use of biomass for energy and/or to further develop agriculture and forestry to increase biomass production per unit of land.

This means that the use of biomass for heating purposes can only be considered as a transition technology, and long-term investment in heat production facilities based on non-waste biomass should be avoided⁶. In the future, only biomass residues which have no other possible use will be deployed to generate heat.

Some renewable energy sources show variation in their availability, e.g. wind and solar sources. And some energy requirements exhibit variation discordant to the variation in the availability of renewable energy sources. The satisfaction of various types of short-term energy requirements (whether electricity, heating, or cooling, in its simple form) should be evaluated in accordance with the location of the district, the local renewable energy sources, and the energy requirements of the district under study. Another consideration is the use of long-term storage systems, such as borehole storage in locations where excessive production of heat is available for limited periods of time, such as solar insolation in summer.

Some more examples of excessive production of heat can be found with large-scale HPs that produce cooling to be supplied to the district in the summer period. The waste heat recovered could be stored in a borehole storage system. The same applies to heat recovered from the waste heat of supermarket cooling systems.

⁶This conclusion may not be suitable for countries with abundant forest resources as in Finland.

Annex X Final Report: Toward 4th Generation District Heating

Considering the ease with which almost any type of heat source can be integrated with low-energy DH systems, a decision support tool would be beneficial in evaluating the availability and performance of local renewable sources to satisfy energy requirements such as electricity, heating, and cooling (this can be further extended to generating other useable outputs like biogas, hydrogen, cooking, and clean water). Lifecycle cost assessment of energy conversion technologies including specific investment cost data, economies-of-scale, and levelized costs of operation and maintenance, and salvage costs at the end of the lifetime of the technology can help find optimal solutions to meeting the energy requirements considered.

The future trend to develop LTDH network heat sources will move from highly hierarchical, “unidirectional” systems based on a few large-scale heating plants, to more sophisticated and smarter, multiple heat sources at multiple locations and bi-directional heat transport networks as illustrated in Figure 8.1.

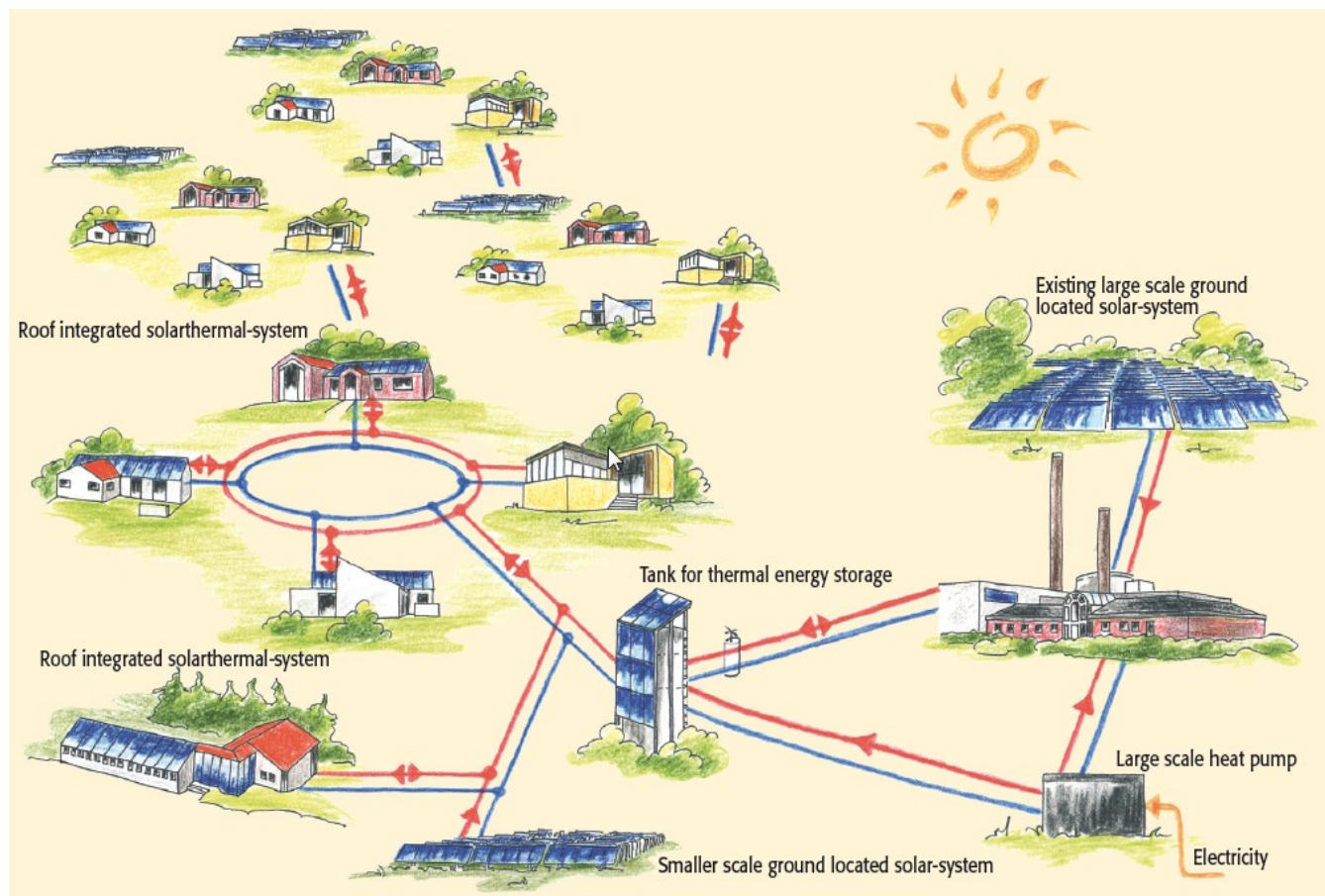

Figure 8.2 Illustration of a multi-source DH system, with a central, large-scale solar thermal system, decentralized solar thermal panels, centralized HP, CHP, and excess heat and thermal storage. Derived from www.braedstrup-fjernvarme.dk.

8.2 Decentralized Heat Generation

To connect non-urban areas to an existing DH network, extra pipelines need to be built with increased heat loss and maintenance work. The economic feasibility and environmental effect of connecting a non-urban area to an existing network should be evaluated in comparison with other decentralized heat supply options, such as individual HPs, solar thermal collectors, or micro CHPs. Decentralized heat generation does not need long-distance heat transportation. It is ideal for supplying areas remote from the central DH network with a limited number of users and limited heating demand.

Small-scale CHPs are emerging on the market and have the potential for rapid development due to cost reduction and efficiency improvement, and easier maintenance and operation. Such technologies include gas turbines, reciprocating engines powered by biogas and fuel cells powered by hydrogen. In comparison with centralized DH and large CHP plants, the specific capital investment for decentralized heat/power generation units is still high and their energy conversion efficiency is still low, but the implementation of LTDH networks will create the opportunity to integrate many other decentralized and sparse micro-sources of heat, such as low-temperature waste-heat from industrial and commercial activities. This will create a more complex and “smart” grid, similar to what is foreseen for the electricity grid.

8.2.1 Micro Heat Pumps for DHW Preparation

8.2.1.1 Introduction

In several individual heating technologies, the highly efficient, decentralized heat pump can use the electricity from excess wind energy and convert it to district heating. Coupled with heat storage units, it has the potential to increase the share of wind energy [40]. The decentralized HP is also a cost-effective solution for providing heat to rural and sparse urban areas which are cost-inhibitive to connect to the DH network. The Heat Plan in Denmark predicts that individual HPs will cover 25% of all heating demand with the remaining 70% supplied by DH [41].

In the LTDH system, one of the central criteria is to reduce the DH supply temperature as low as possible so as to minimize network heat loss. However, due to the hygienic constraints of DHW supply, the DH supply temperature cannot be lowered below 50°C at the consumer end. When the heat source temperature drops below 50°C, solutions have to be found to boost the forward temperature to satisfy DHW needs. One idea is to use a decentralized HP with a storage tank to recover waste heat and boost the low temperature heat source from 40°C to produce DHW at 45°C [42]. SH can use heat sources with a temperature close to room temperature with an FH system, so the main focus of the concept is to use micro HP to produce DHW at 45°C.

8.2.1.2 System Configuration

The HP and storage tank are dimensioned using the tapping load profile in the Danish standard DS439 and the assumptions made in Table 8.2. Three system configurations (Figure 8.4 Micro-

Annex X Final Report: Toward 4th Generation District Heating

booster HP configurations) are proposed with regard to the position of the HP, the heat source for the evaporator, and whether there is pre-heating of tap or return water.

The first two variants implement the HP on the primary side to boost the DH supply temperature prior to the DHW HE.

1. Variant A: The DH forward flow is split into two streams at the consumer entry point. The two streams flow through the HP condenser and evaporator separately. The HP condenser heats up the first stream from 40°C to 53°C, while the evaporator extracts heat from the second stream and cools it down to 25°C. The heated DH water is stored in a stratified accumulator tank and instantaneously used for the micro HE when tapping starts.
2. Variant B differs from Variant A on the heat source for the evaporator. In variant B, the return water from hot water HE is used as the heat source for the HP. Variant B thus requires less DH flow than Variant A.

Variants A and B separate the DHW supply and the DHW storage with a micro HE, which eliminates the risk of legionella if the secondary side water volume is designed to be less than 3 litres.

3. Variant C implements the HP on the secondary side and to heat the tapping water directly. The DH forward flow is split into two streams. The first stream flows through evaporator as the heat source. The second stream flows through a pre-heating HE which heats up the tapping water from 10°C to around 38°C. Through the condenser, the preheated tap water is then heated up to 55°C and stored in the stratified tank for direct use.

Table 8.2 Assumptions for the micro-HP booster

Variable	Assumption
Refrigerant	R600a
Pinch temperature in Tap-water HEX (QMAX=32 kW)	8 [°C]
HEX pinch temperature difference in both Condenser and Evaporator	2.5 [°C]
Isentropic efficiency of compressor	0.5
DH network forward temperature	40 [°C]
Temperature of DH return from the evaporator (Variants A & C)	25 [°C]
Hot tap water	45 [°C]
Tap water in	10 [°C]

Annex X Final Report: Toward 4th Generation District Heating

8.2.1.3 Thermal Analysis

Based on the assumptions, the three micro-HP DHW heating systems were simulated with a numerical model developed in Engineering Equation Solver (EES). Table 8.3 shows the simulation results.

Table 8.4 Design values for the micro-HP

	Micro-booster HP variants		
	A	B	C
DH flow, l/h	85	50	75
Power, W	142	214	155
Coefficient of performance (COP)	5.3	3.5	5.0
Storage size required, l	128	128	100

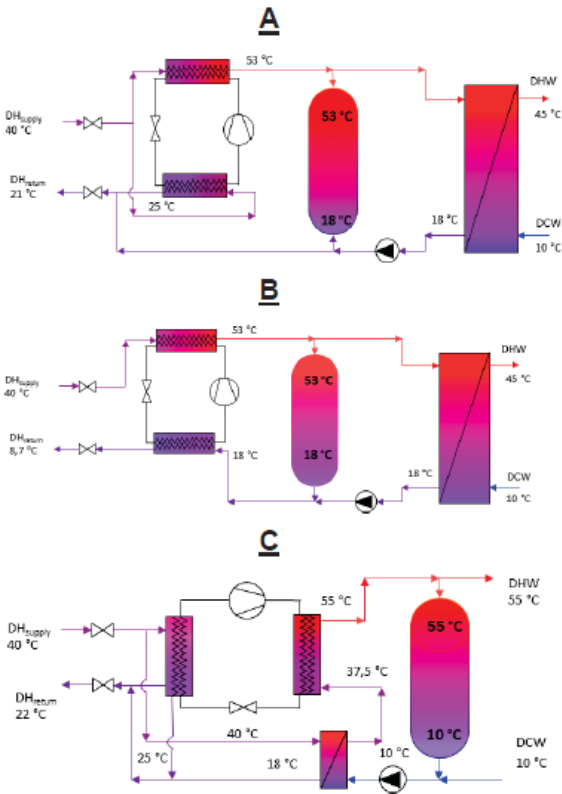

Figure 8.4 Micro-booster HP configurations [42]

Annex X Final Report: Toward 4th Generation District Heating

Variant A has the lowest average temperature difference between the evaporator and the condenser, so it has the highest COP value and the lowest power capacity. However, it requires the highest DHW flow. Variant B uses HE return water (around 18°C) as heat source, so its COP value is the lowest of the three configurations, and it has the highest power capacity. Variant C uses the same heat source temperature as Variant A, but with slightly lower condenser inlet temperature and higher condenser outlet temperature, which makes its COP value slightly lower than that of Variant A.

8.2.2 Integration of MTDH and LTDH using Heat Pumps

In regions or areas with developed DH, one of the strategies to enhance the market penetration is to connect the existing DH network to adjacent settlements with reduced network supply temperature. Such extension is possible without capital intensive investment in heating plants, and uses the existing network to transport extra heating power capacity. This has been implemented in the Lystrup project in Denmark, using a shunt to mix the supply water from the existing medium temperature DH (MTDH) network and the return water from the LTDH network.

However, such a strategy will encounter barriers if there is limited transportation capacity redundancy in the existing network. Moreover, pumping power consumption will increase to deliver the extra flow capacity. An alternative solution is to use the thermal energy from the return pipeline of the existing network in a cascade way and use a HP to boost to the desired supply temperature. This idea has been analysed for a small residential area with low heating demand [43]. The analysis was based on an exergy approach, but only the energy performance is reported here.

8.2.2.1 System Configuration

Figure 8.6 shows a schematic of integration between MTDH and LTDH networks using a small central heat pump. The LTDH network was assumed to connect to an existing large MTDH network. The return water from the MTDH network at 40°C passes through the HP condenser and is boosted to the desired LTDH network supply temperature of 55°C. The return water from the LTDH network passes through the evaporator and is further cooled before it returns back to the MTDH network.

The HP benefits greatly by using the LTDH network return water as its heat source. Compared to an air source, the network return water provides a stable heat source which will reduce HP operational costs. The HP does not need to reverse the cycle to prevent frost accumulated on the evaporator coil during a cold winter, and can therefore maintain a high COP value. And compared to a conventional ground source, it saves the initial investment for burying the HE underground or providing a well for the energy sources.

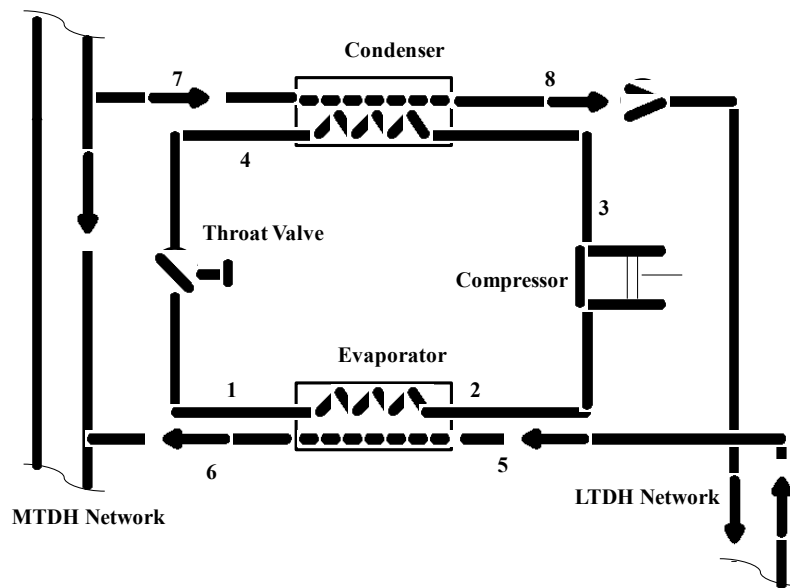

Figure 8.6 Integration of MTDH and LTDH network with an HP[43]

8.2.2.2 Thermal Analysis

The HP was simulated taking into account four major components: the compressor, the condenser, the throttling valve, and the evaporator. The thermal value for each component in the design state is presented in Table 8.5. The energy/exergy balances can be established based on three loops: the HP loop, the LTDH network loop, and the end-user loop.

In an HP system, the heat rejected at the condenser (heat sink) is the sum of the heat removed from the evaporator (heat source) plus the ideal compressor work. The heating loop, which consists of the condenser and the heating units, is normally a closed loop. This means that the final utilized energy is always smaller than the energy supplied from the condenser due to possible heat losses. In the proposed HP system, the heating circuit is an open loop. The water supplied from the condenser can drop to a temperature lower than the condenser inlet water temperature, which means that the final utilized energy exceeds the energy recovered from the condenser itself.

HP heating efficiency is rated as COP (coefficient of performance). According to the conventional definition, this is the ratio of heat output from the condenser to the compressor work input. This definition of COP is based on the closed loop, which results in a COP value of 4.41. When considering the heating loop as an open circuit, the energy output from the HP becomes energy input to the LTDH network, rather than the condenser heat output. In this case, the ideal HP COP increases to 8.9. This shows the great advantage of using HPs to recover waste heat from the district heating network return pipeline.

Annex X Final Report: Toward 4th Generation District Heating

Table 8.6 Thermal properties at different HP circuit locations

Location	Refrigerant	Phase	Temperature °C	Pressure kPa	Mass Flow Rate kg/s	Energy Rate kW
Evaporator Inlet	R-134a	Mixture	10.0	415	0.218	29.66
Evaporator Outlet	R-134a	Superheat	12.0	415	0.218	56.22
Condenser Inlet	R-134a	Superheat	71.8	1683	0.218	64.01
Condenser Outlet	R-134a	Liquid	58.0	1683	0.218	29.66

9 LTDH Implementation: Case Studies

Experience with LTDH has been obtained in several places around the world. The objective of this chapter is to report and discuss some lessons learnt from significant case studies, documented in the Appendix. The locations of these seven case studies are shown in Figure 9.1.

Each project highlights particular aspects: the integration of energy-efficient buildings and DH, energy-efficient and low-temperature operated networks, carbon-neutral heat supply systems, multi-source heat supply systems, or a combination of these aspects. In this way, they have all contributed to the development of 4th generation DH systems, although none of them fully realizes the vision previously described. Nevertheless, they have demonstrated the potential and the strategic value of the concepts, technical improvements, operation strategies and implementation processes which could be unified and applied in future projects.

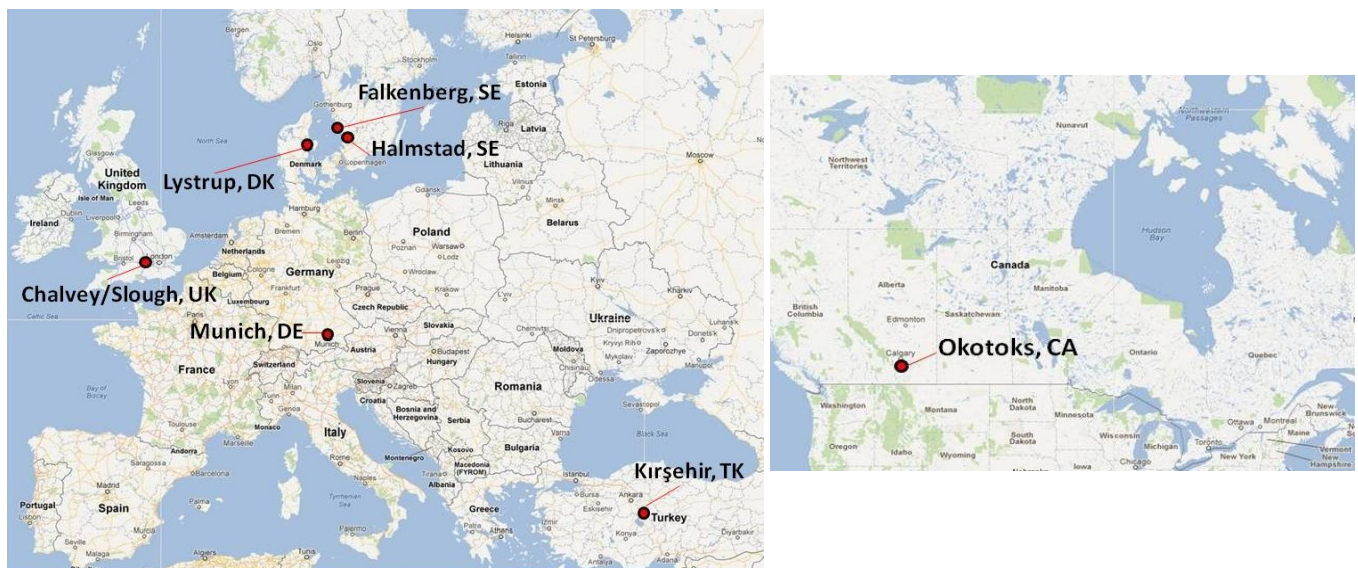

Figure 9.1 Geographical locations of the seven case studies.

Annex X Final Report: Toward 4th Generation District Heating

The seven case studies analysed are:

Denmark:

- LTDH network for forty newly-built low-energy single family-houses at Lystrup finalized in 2009. More information about this system can be found in [44]. The information collected is for the 2011 operation year.

Sweden:

- DH for SH and DHW demands in multi-family passive houses at Hertings Gård in Falkenberg finalized in 2008 and 2010. The information collected is for the 2011 operational year.

- DH as base load heat supply to newly-built multi-family passive houses at Söndrum Kyrkby in Halmstad finalized in 2010. The information collected is for the 2011/2012 heating season.

These two district heating areas are connected to ordinary district heating system with traditional MTDH temperatures. They were chosen to illustrate the characteristics of current new buildings in Sweden. The heat supplied to these distribution areas was not measured, so the local distribution heat losses have been estimated from standard values for twin pipes locally used in these two areas.

United Kingdom:

- Experimental, multi-source low-temperature DH system for ten energy-efficient houses at Chalvey in Slough finalized in 2010. The information collected is for the 2011 operation year.

Germany:

- Solar DH network with seasonal heat storage at Ackermannbogen in Munich, finalized in 2006. More information about this site can be found in [45]. The information collected is for the 2008/2009 heating season.

Two of the locations were in other than the project participating countries:

Turkey

- Geothermal low-temperature DH system for existing buildings in Kırşehir started in 1994 and finalized in 1995. Only the temperature level and building area information were available for this site.

Canada

- Solar DH network with seasonal borehole heat storage at the Drake Landing Solar Community in Okotoks, Alberta, finalized in 2007. More information about this site can be found in [46] and [47]. The project has a very informative website [48] with annual reports containing both operation statistics and experience gained. The information collected is an average of the 2009/2010 and 2010/2011 heating seasons.

Annex X Final Report: Toward 4th Generation District Heating

9.1 Overview analysis of case studies

The information gathered and the characteristic parameters estimated for the seven case study locations are presented in Table 9.1.

Table 9.1. Overview of characteristic distribution parameters for seven district heating areas analysed. Nine input parameters were used for estimating ten output parameters in green columns. Temperatures and heat flows consider annual values from information gathered from the internal case study reports and complementary sources. Only four input parameters were available for the Kırşehir system in Turkey.

INPUT PARAMETERS	Temperature level			Concentration			Heat balance		Distribution			
	Supply, °C	Return, °C	Outdoor, °C	Land area, m ²	Building area, m ²		Heat supplied (input), GJ	Heat sold (output), GJ	Trench length, m	Average outer media pipe diameter, m		
Kırşehir, Turkey	57	38	11.3	na	180000		na	na	na	na		
Ringgården 34, Lystrup, Denmark	52.7	34.1	7.8	17000	4115		986	790	767	0.021		
Drake Landing, Okotoks, Canada	39.9	31.9	3.9	29500	7650		2705	2564	1045	0.043		
Söndrum, Halmstad, Sweden	70	38	7.3	12000	4307		920	809	470	0.038		
Herting, Falkenberg, Sweden	78	44	7.3	14000	10208		1374	1252	342	0.076		
Ackermannbogen, Munich, Germany	59	33	9.6	23000	28550		6534	6379	1240	0.076		
Greenwatt Way, Slough, UK	51.2	34.4	11.2	1800	845		178	129	165	0.032		
OUTPUT PARAMETERS	Temperature level			Concentration			Heat balance		Distribution			
	Degree time integral, k°CCh			Plot ratio	Heat density, MJ/m ²	Effective width, m	Distribution heat loss, GJ	Specific heat demand, MJ/m ²	Outer media pipe area, m ²	Relative distribution heat loss		
Kırşehir, Turkey	317			na	na	na	na	na	na	na	na	na
Ringgården 34, Lystrup, Denmark	312			0.24	46	22	196	192	101	20%	1.0	1.7
Drake Landing, Okotoks, Canada	280			0.26	87	28	141	335	282	5%	2.5	0.5
Söndrum, Halmstad, Sweden	409			0.36	67	26	111	188	112	12%	1.7	0.7
Herting, Falkenberg, Sweden	470			0.73	89	41	122	123	163	9%	3.7	0.4
Ackermannbogen, Munich, Germany	319			1.24	277	19	155	223	592	2%	5.1	0.2
Greenwatt Way, Slough, UK	277			0.47	71	11	50	152	33	28%	0.8	1.5

The following definitions from [49] were applied in the analysis:

- I. Degree time integral is the annual average temperature difference between the network temperatures and the outdoor temperature times the number of hours in a year (8760 h), a measure of the temperature level.
- II. Plot ratio is the ratio between the building space area and the associated land area, a measure of how concentrated the buildings are on the land area.
- III. Heat density is the ratio between the heat sold and the associated land area, a measure of how concentrated the heat demands are compared to the land area.
- IV. Effective width is the ratio between the trench length and the associated land area, a measure of how much distribution pipe is needed for a land area.
- V. Distribution heat loss is the difference between the heat supply input and the heat sold output in the distribution network.
- VI. Relative distribution heat loss is the ratio between the distribution heat loss and the heat supply input, a measure of the heat lost to the environment from the heat distribution.

Annex X Final Report: Toward 4th Generation District Heating

- VII. Linear heat density is the ratio between the heat sold output and the trench length, a measure of how concentrated the heat demands are compared to the trench length needed.
- VIII. Heat transfer coefficient refers to the associated warm area, which is the outer media pipe area from two media pipes, one for supply and one for return.

9.1.1 Temperature level

The degree time integral was chosen as temperature level indicator. According to Figure 9.2, this parameter varies between 280 and 320 k°Ch for the five areas with low temperature distribution. The two Swedish areas are connected to ordinary MTDH systems with higher temperature levels. Future ideal LTDH network temperatures of 50-20°C will give a degree time integral of 220 k°Ch. Typical temperature levels in current European MTDH systems are 450-600 k°Ch. The current national averages in Denmark and Sweden are 440 and 500 k°Ch, respectively. So the temperature level in the low temperature areas will be almost half of the temperature level in the current MTDH systems.

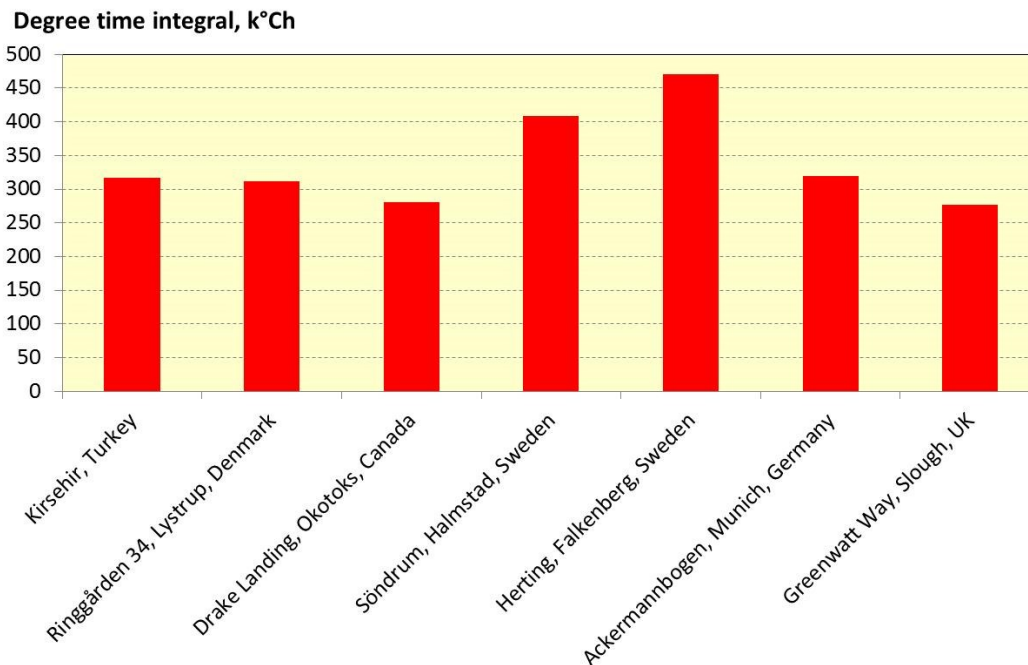

Figure 9.2. Degree time integral as temperature level indicator. This parameter is the main driver behind the distribution heat loss.

However, there has the potential for improvement because expected low return temperatures were not reached in the low temperature areas. The Lystrup area in Denmark was designed for 55-25°C, but was operated on average with 53-34°C in 2011. The Ackermannbogen area in Germany was designed for 55-30°C, but was operated with 59-33°C during the 2008/2009 heating season.

Annex X Final Report: Toward 4th Generation District Heating

The main conclusion with regard to the temperature level is that significantly low temperature levels have been reached, but a robust strategy for reaching lower return temperatures is lacking and is really needed for the future if we are to achieve all the benefits of LTDH.

9.1.2 Concentration

Heat density was chosen as the concentration indicator. A high concentration of heat demands gives low distribution capital costs and low distribution heat losses as described in [9][49]. According to Figure 9.3, the highest heat density was found at Ackermannbogen with 277 MJ/m². Five other areas vary between 45 and 90 MJ/m². One common European opinion about a threshold for district heating viability is 150 MJ/m², based on competition with fossil fuels for heating. However, a future threshold might be as low as 40-80 MJ/m², when no fossil fuels are used for heating. This level has already been reached in Sweden and Denmark, where high taxes are applied for fossil fuels used for heating.

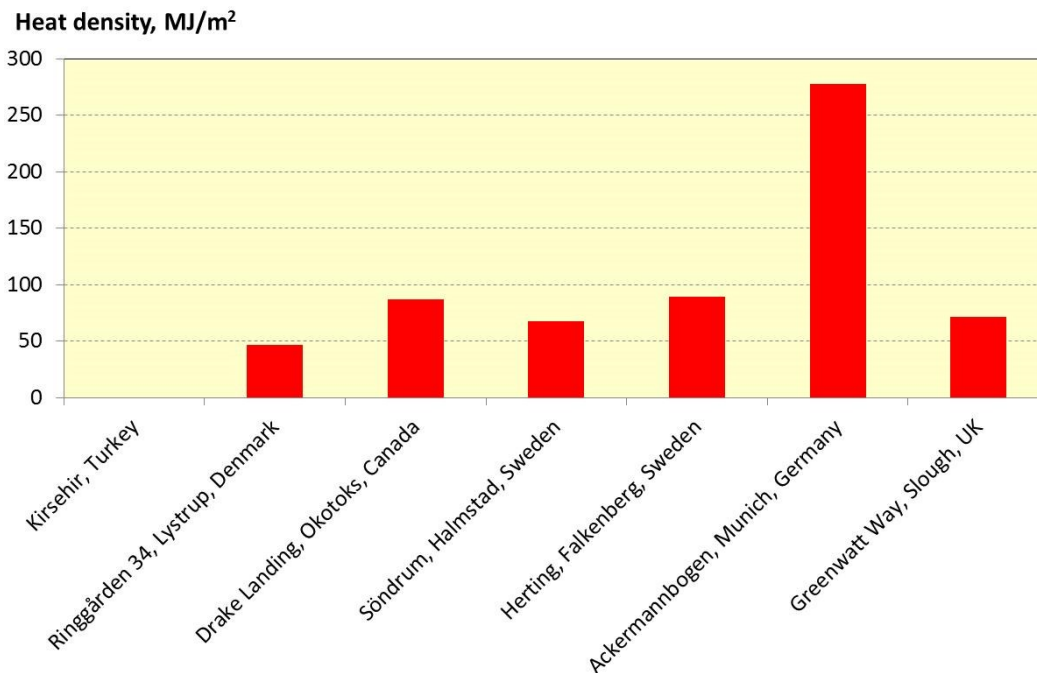

Figure 9.3. Heat density as concentration indicator. This parameter is important for the distribution capital cost.

The main conclusion with regard to heat density is that most of these early demonstration areas are associated with low heat densities, but the Ackermannbogen case from Germany shows that future buildings also can be built with high heat densities although the specific heat demands are low.

9.1.3 Heat balance

Annex X Final Report: Toward 4th Generation District Heating

The specific heat demand was chosen as the heat balance indicator. According to Figure 9.4, the specific demands vary between 120 and 340 MJ/m², where the highest specific demand was found in Okotoks, Canada and the lowest in Falkenberg, Sweden. If we leave aside the highest value, the variation is between 120 and 220 MJ/m². These demands are 55-75% lower than the European average of about 500 MJ/m², giving a good estimation of what kind of heat demands to expect from future buildings.

The main conclusion with regard to specific heat demands is that these case studies show that LTDH systems can supply heat to low-energy buildings.

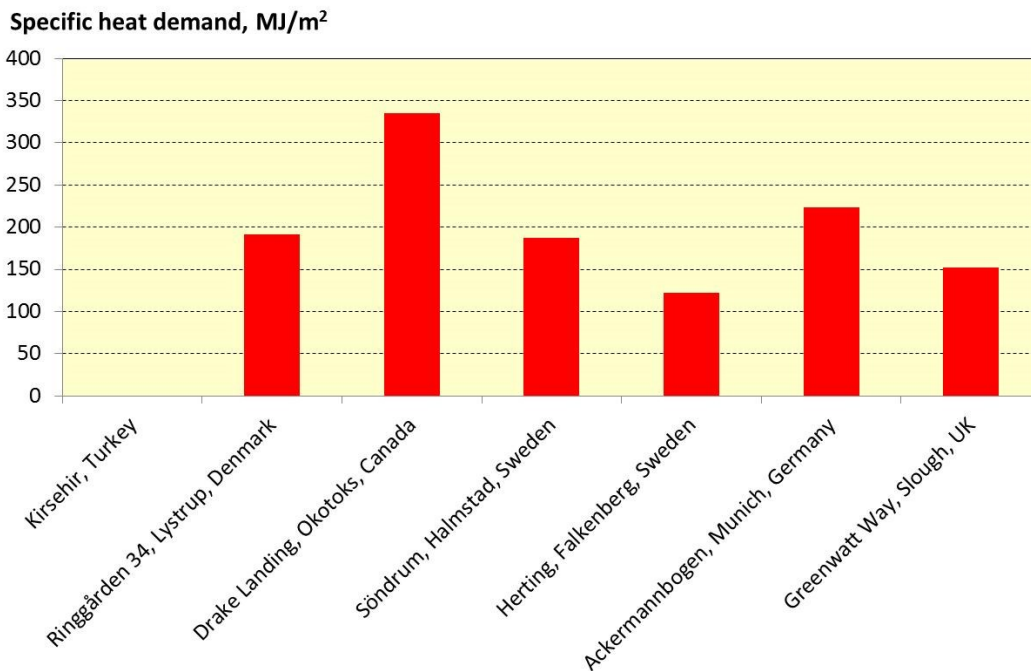

Figure 9.4. Specific heat demand as heat balance indicator. This parameter is an essential customer condition for heat distribution.

9.1.4 Distribution

The heat transfer coefficient was chosen as the indicator for heat resistance in the distribution network. These coefficients were estimated from the annual distribution heat loss, the outer pipe area, and the degree time integral. According to Figure 9.5, the values of these coefficients vary a great deal in the case study group. First, the two Swedish areas were not estimated from the actual distribution heat loss, but from the heat transfer coefficient for twin pipes. That is why they are both located on the curve for twin pipes. Second, the remaining four estimates are divided into two groups. Lystrup and Greenwatt Way have high heat transfer coefficients (1.5-1.7 W/m²K) and Okotoks and Ackermannbogen have low heat transfer coefficients (0.2-0.5 W/m²K).

Annex X Final Report: Toward 4th Generation District Heating

Conventional systems with similar average pipe diameters have heat transfer coefficients of 0.8-1.4 W/m²K when two single parallel pipes are used, and 0.4-0.8 W/m²K when twin pipes are used. This suggests that one conclusion from this analysis is that the measured distribution heat losses have been overestimated at Lystrup and Greenwatt Way, and underestimated at Okotoks and Ackermannbogen. The estimated distribution heat losses in these areas are not true estimates for real distribution heat losses. If twin-pipe heat resistances had been used for estimation, the relative distribution heat loss would have been 10% instead of 20% at Lystrup, 6% instead of 5% in Okotoks, 5% instead of 2% at Ackermannbogen, and 15% instead of 28% at Greenwatt Way. This shows that distribution heat losses are not a decisive barrier for district heating in areas with low-energy buildings.

Heat transfer coefficient, W/m²K

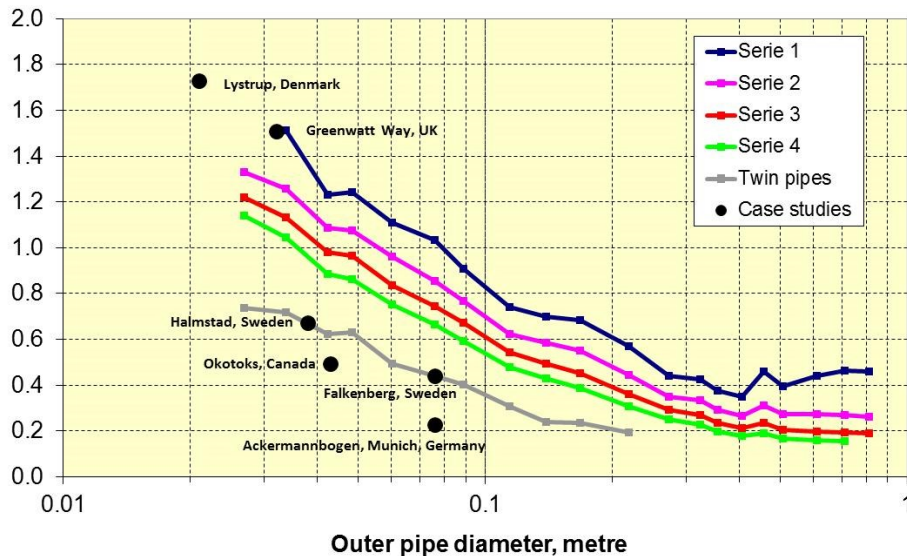

Figure 9.5. Heat transfer coefficient as indicator for the heat resistance in the distribution network. This parameter is the main moderator behind the distribution heat loss. Corresponding values for various insulation series for commercial prefabricated distribution pipes have been added to facilitate a comparison with the estimates from the case studies. Serie 1 has a low insulation thickness and Serie 4 has a high insulation thickness for two single parallel pipes buried in the ground. Twin pipes are two media pipes in a common insulation casing pipe.

The main conclusion with regard to the network conditions is that the heat transfer coefficient can be reduced by half compared to current conditions, if twin pipes are used in areas with low heat densities.

Annex X Final Report: Toward 4th Generation District Heating

9.1.5 Distribution capital cost

The distribution capital cost was estimated for each case study area using Equation (1). The constant and the coefficient for estimating the unit cost of putting pipes into the ground were estimated from the cost level for new construction sites in Sweden in 2007. The cost estimates are presented in Table 9.2. These cost estimates vary between 3 and 14 €/GJ, which is higher than for traditional district heating systems. The high estimates are due to the low heat densities in the case study areas. However, these distribution capital costs might be competitive in the future when competing fossil fuels are more heavily taxed with carbon taxes to discourage using fossil fuels for heating.

Table 9.2. Distribution capital cost analysis according to the Swedish 2007 cost level for new construction sites.

	Investment cost, €/m	Annual distribution cost, €/GJ	Investment cost level chosen for the analysis			
Kirsehir, Turkey	na	na	C ₁ =	80.1	€/m	
Ringgården 34, Lystrup, Denmark	115	8.9	C ₂ =	1656	€/m ²	
Drake Landing, Okotoks, Canada	151	4.9	annuity =	0.08		
Söndrum, Halmstad, Sweden	143	6.6				
Herting, Falkenberg, Sweden	206	4.5				
Ackermannbogen, Munich, Germany	206	3.2				
Greenwatt Way, Slough, UK	133	13.7				

9.1.6 Summary of the analysis conclusions

The preceding analysis has shown that lower temperature levels were applied in some of the case study areas. The combined effect of cutting the temperature level in half and cutting the heat transfer coefficients in half (by using twin pipes) is that the annual distribution heat losses can be reduced to a quarter of the current loss level at the same heat density. This means that the current relative distribution heat loss level of 10-15% can be maintained when the future specific heat demands are a quarter of the current heat demands.

Distribution capital costs will be higher in the future than in the current situation if heat densities are as low as in these case studies. However, most district heating areas are associated with higher heat densities. So distribution capital cost should not be a major barrier for future district heating, since most urban areas are very dense, cf. section 2.1.1 in this report.

9.2 Lessons learnt from early projects

Extrapolation of current technology: Experience from the projects selected demonstrates how the LTDH concept is based on existing technology or optimization of existing technology and therefore

Annex X Final Report: Toward 4th Generation District Heating

does not require totally new products or technologies. The main requirements are careful design practice and attention to the optimal integration of subsystems for heat supply, heat distribution and heat use.

Extensions from current systems: The case study at Lystrup, Denmark shows how existing networks could be extended to supply low heat-demand building areas via shunt valves, which is particularly beneficial in countries with a well-established DH infrastructure.

Design conditions: The design of distribution networks and building installations must be accurate and new knowledge needs to be fed into design practices. The design of new generation DH systems must holistically combine end-user requirements (thermal comfort, occupation of space for building SH and DHW equipment), heat supply side requirements (energy-efficiency and option of including low-grade energy sources and RE), and society-level targets (environmental responsibility and overall economy)

Design without major margins: The implementation process should rely on knowledge-based decisions with the best available methods (either information from practical demonstration projects or from model-based design and optimization tools), instead of traditional, reliable, but possibly too conservative parameters.

Balancing demands with renewable heat: The example of the solar thermal system in Okotoks, Canada (where 100% of the heat demand is supplied by solar thermal systems) demonstrates that fully RE-based DH systems are technically possible, but expensive. This means that the specific energy demand must be reduced first.

Demand profiles: Energy-efficient buildings reduce SH demand by a factor 3-5 compared to existing buildings, and that levels out the annual heat load curve for DH systems. This is very valuable, because it could reduce the ratio between the required installed capacity at the heat plants (in MW_{th}) and the total annual heat demand (in MWh_{th}). This is particularly interesting for systems which are required to be totally based on RE and excess heat, where peak-load and back-up facilities are dramatically expensive.

Demand temperature levels: LTDH has the potential to be economically viable even in the existing building stock, as proven by the case study in Kırşehir, Turkey. A careful analysis of the present conditions of the building envelope of the buildings, combined with understanding of the performance of their SH and DHW installations, can indicate the minimum necessary investments to be made to adapt the buildings for LTDH requirements. The case in Kırşehir is an example of how past building energy design based on steady-state calculations and conservative assumptions often led to over-dimensioned SH systems, which could therefore be used with decreased operating temperature for most of the time and with acceptable investment costs.

Heat storage: Advanced storage technologies will be necessary in future systems, both with regard to central large-scale thermal storage systems and decentralized small-scale thermal storage equipment. Finally, low operating temperatures fit well the targets for energy efficiency and a large share for solar thermal energy.

Annex X Final Report: Toward 4th Generation District Heating

Power system interaction: In a carbon-neutral society, the possibility of effectively integrating and optimizing electrical power storage and heat storage should be investigated, from both the technical and the economic point of view, so that the one serves the needs of the other.

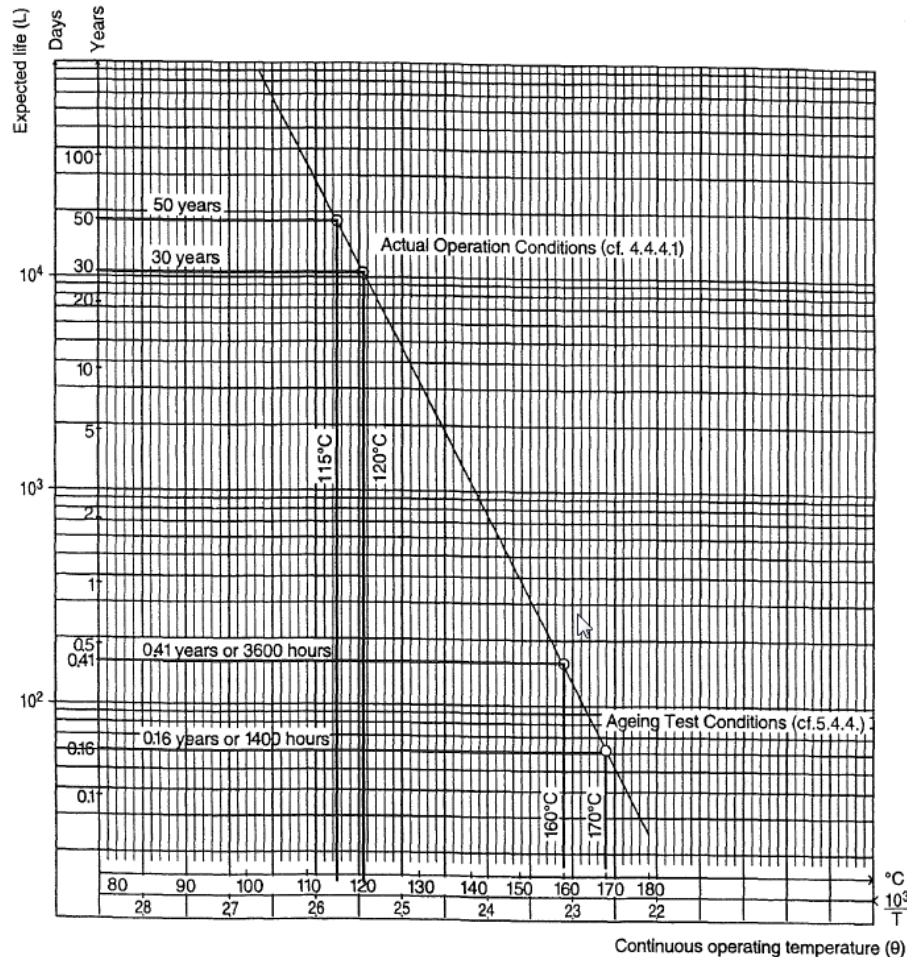

Figure 9.6 Relationship between expected pipe lifetime and continuous operating temperature for the minimum requirements outlined in EN 253:2009.

Pipe lifetimes: The life span of the equipment will be extended. For example, as a consequence of the lower average operational temperature in LTDH networks, longer pipe lifetimes can be predicted according to Annex A in EN 253:2009, replicated in Figure 9.6. The Standard recommends that, in normal applications, the pipe assembly should have a lifetime of at least 30 years at a continuous operating temperature of 120°C, of at least 50 years at a continuous operating temperature of 115°C and more than 50 years at a continuous operating temperature below 115°C. The lifetime of pipe assemblies with a heat-carrier temperature constantly below 70°C could be well above 70 years.

Business models: With regard to economics, LTDH systems are essentially characterized by relatively low operational costs. This is valid for DH in general, but the difference between total and operation

Annex X Final Report: Toward 4th Generation District Heating

costs is further increased with low-temperature systems. This means that new tariff systems and leadership from public authorities will be necessary.

System functioning: The practice of increasing the supply temperature during peak loads must be applied to low-temperature systems whenever possible, as is already done in medium-temperature systems, because it keeps the investments to the minimum level achievable with low-temperature equipment. The main challenge is to find medium-temperature, carbon-neutral heat sources. Biomass and biogas could be used for this purpose, but their use should be limited as much as possible and solely for a transition period.

Temperature level: Future DH systems based on RE and excess heat will generally be based on a combination of heat sources. The focus on RE and excess heat exploitation, and the strict energy efficiency requirements will mean choosing the lowest possible operating temperatures. Keeping that in mind, the operating temperatures must still be chosen taking into account the overall costs involved (heat sources, network, building installations). The case study in Kırşehir exemplifies this statement.

Temperature level: DH schemes which exploit solar thermal energy, such as the examples in Munich, Germany, and Okotoks, Canada, benefit greatly from both low supply and low return temperature. Cases where low-temperature excess heat has an important role in preheating the supply temperature are particularly sensitive to the level of the return temperature. This underlines how economic parameters and the type of heat source(s) are the most decisive factors in the choice of operating temperatures.

Continuous commissioning: The monitoring of equipment and system performance is decisive for applying continuous commissioning practices, recognizing malfunctioning as it appears, and implementing suitable improvements, as happened in the case studies at Lystrup, Denmark.

10 Conclusions

10.1 LTDH advantages

The main advantages of LTDH in heat distribution are reduced heat losses, improved harmonization between heat supply temperatures and heat demand temperatures, reduced thermal stress in steel pipes, the possibility of using other pipe materials, reduced boiling risk, and reduced risks for scalding.

The main LTDH advantages in heat supply are improved power-to-heat ratios in steam CHP plants, greater heat utilization from flue gas condensation when using fuels with moisture, higher coefficients of performance in heat pumps, greater utilization of low-temperature industrial excess heat, increased utilization of geothermal heat, higher conversion efficiencies in central solar collector fields, reduced heat losses, and greater utilization of thermal storage.

The current barriers for LTDH are high-temperature heat demands, legionella growth at low hot-water temperatures, substation faults, and shortcut flows in distribution networks.

The main conclusion from the LTDH advantage analysis is that LTDH systems provide more diversified heat supply options, greater heat supply efficiency, and greater heat distribution efficiency.

10.2 Planning and Technical issues

The Planning of DH

DH systems have a long lifetime and can be operated with a strategy that combines reduced network supply temperature with extension to adjacent areas which are supplied with individual heating units. The profitability of extending an existing DH network and the threshold for DH market share can be indicated through the specific distribution cost.

To find an optimal energy supply structure and identify the role of DH in the energy supply system of the future, a strategic energy planning approach can be applied to optimize the entire energy infrastructure to achieve the target for a low-carbon economy and minimize total long-term investment.

With the existing DH infrastructure, DH utilities benefit from selling more heat to the consumers. The development of the next generation of DH, however, requires a renewable energy supply system which is characterized by being capital intensive and having a long lifetime. The transition from current DH systems to the next generation DH system requires coordinated efforts for building energy reduction and wide exploitation of low-grade waste heat and RE. This will stimulate a paradigm shift from selling more heat is good for business to selling less heat is good for business. With a significant building energy reduction, the heating demand will be levelled out throughout the year, which means DH utilities profit from savings in peak-load facility investment. The level of building energy saving and the reduction in renewable-based heating plant installed capacity will depend largely on the decisions on socio-economic criteria made by policy makers through regulations and incentives.

Annex X Final Report: Toward 4th Generation District Heating

In-House Substations

A well-designed and functioning DHW system must fulfil the requirements for hygiene, thermal comfort and better energy efficiency. One of the major barriers to implementing LTDH is the increased Legionella risk with supply temperatures close to 50°C. A literature survey was conducted for this report to identify DHW supply regulations around the world. We have reported a statistical study on the growth of Legionella in different DHW installations at different temperature levels. Various treatment solutions have been introduced to reduce or eliminate Legionella bacteria.

In small residential buildings, the DHW system can be operated below 50°C without using external treatment or recirculation if the water volume in each DHW supply line, including the water content on the secondary side of HE, can be limited to 3 litres. The same design philosophy can be used in multi-storey buildings if a station unit is installed in each apartment.

There are different types of in-house DHW installation, typically including DHSU or IHEU. In the DHSU design, the storage tank is moved from the secondary side to the primary side to avoid the risk of Legionella. Though the storage tank may shave the peak heating load, allowing a reduction in the diameter of distribution pipes, such advantage should be further justified by considering the size of the tank and using a more realistic simultaneous factor to design the distribution pipes. IHEU is a comparatively simple and cost-saving solution. It has better cooling than DHSU. The negative side of IHEU is that it dimensions the network in accordance with the peak DHW load, which means larger service pipe diameters. Meanwhile, LTDH has a much lower mean temperature and therefore requires novel HEs with an increased unit heat transfer rate and more accurate fast-response thermal control.

LTDH Supply to Residential Buildings

One of the incentives to supply LTDH is to adapt existing DH to a sparse area or an area where building energy consumption has become low. The low-temperature SH system should be selected to fit the low-energy building demand with regard to various criteria such as energy consumption, the ability to shave the peak heating demand, the network return temperature, and consumer thermal comfort. Special attention should be paid to the design of SH systems for low-energy buildings with regard to the overheating problem in summer conditions.

But the majority of buildings are not new. The large-scale implementation of LTDH relies on its use in existing buildings. The studies show that with the aid of varying network supply temperature and light building renovation, it is possible to supply LTDH to existing buildings prior to extensive building renovation.

DH Network

To make LTDH economically competitive with individual heating units in a sparse DH area, the design and operation of the DH system should be optimized to minimize the total cost, including the total investment and annual O&M cost. To reduce the network heat loss, which accounts for a significant portion of annual operational cost, we studied the performance of the advanced pre-insulated DH twin pipes designed for high pressure in the distribution network. Triple pipes which can deliver supply

Annex X Final Report: Toward 4th Generation District Heating

water with two different diameter pipes and at two different temperature levels were suggested for service pipes to reduce pipe heat loss. Alternatively, they can be used for the 'minimum cooling' bypass strategy.

The operation of a DH system normally has a much higher relative heat loss in summer than in winter due to the use of thermal bypasses. The Comfort Bathroom concept redirects the bypass water through bathroom floor heating, which on one hand improves consumer thermal comfort and on the other hand further cools the bypass water.

Heat Sources

LTDH will improve CHP plant performance, enhance low-grade waste heat recovery, and increase the renewable heat generation efficiency. Among the different types of renewable sources, biomass is currently the most utilized renewable sources, but it is only recommended for the transition period due to the shortage of available land use and the priority for biomass use in other sectors.

The use of the various forms of renewable energy should be evaluated in the local energy framework, taking into account heating, cooling, electricity and transportation. The intermittent energy production pattern of renewable energy means that energy storage is required to match the heating supply with the heating demand.

The trend will be for DH development to move from the highly hierarchical, large-scale heating plant heat generation towards small-scale, more flexible and more controllable decentralized heat generation. The energy at different temperature levels will be used in a cascade way to match different energy demand requirements. To further reduce network heat loss, the DH supply temperature can be reduced to ultra-low level and boosted on-site or close to the consumption point with the aid of heat pumps.

10.3 Legionella issue

Temperature:

Temperatures between 30 and 45 °C are for legionella growth optimal. The most of the national guidelines use a safety distance of minimum 5 K to this range. That means, the main aim is to avoid the temperature range between 25 ° and 50 °C inside the domestic hot water DHW- installation and the installation for potable water cold (PWC).

The temperature at the outlet side of central DHW generator with and without DHW-storage and at the tap point is very different from country to country. The most of the European countries follows more or less the guideline EN 806 and integrate 60 °C at the outlet side of central DHW generator in the national guidelines.

Dwell time, hydraulic aspects

Annex X Final Report: Toward 4th Generation District Heating

The second impact of legionella growth is the dwell time in the above mentioned temperature range for optimal legionella growth. The dwell time should be lower than 24 hours for lowering the risk of legionella-contamination. New methods of centralized domestic hot water generators with significant reduced volume of DHW-storages and new thermohydraulic valves for an improvement of hydraulic balance are good steps also in case of reconstruction. The integration of decentralized flow type heater for DHW for every flat should be chosen for new installations if possible. Such decentralized versions allowed LTDH with 52 to 55 °C at the DH-inlet side of the plate heat exchanger

Legionella in PWC

Legionella also growth in the cold potable water (PWC) if the dwell time is long or/and there is the possibility for unwanted heating up. (e.g. waste heat from the supply line for space heating, DHW). We have taken into account this aspect also in systems with DHW tap temperatures in the range of the temperature for the using purposes. In case of 40 °C DHW-temperatures for a shower the PWC-volume flow is round about zero. *Legionella Treatment*

The most of the thermal and chemical treatment methods are allowed only for a small period (e. g. in case of a legionella contamination) in selected IEA-countries. The limitation is the negative impact on human health (scalding, unacceptable changing of PWC and/or DHW-parameters, corrosion).

10.4 Lessons learnt from early projects

The main lessons learnt from the case studies are:

1. *Generation compatibility*: Fourth generation technology is a controlled extrapolation of the third generation technology. However, the heat demands are much lower. This means that it is more important than ever to apply real and accurate design conditions with respect to heat demands, costs, and operating conditions. This gives less space for design errors and design margins. It is also possible to extend traditional networks into new areas using fourth generation technology.
2. *Temperature level*: To obtain all the benefits of fourth generation technology, it is very important that the systems are designed for lower temperatures and that these lower temperatures can be maintained during the operation of the systems. This requires customer heating systems with low temperature demands, no shortcut flows in distribution networks, and continuous commissioning of the systems to identify new faults that give higher temperature levels.
3. *Heat losses*: Acceptable annual heat distribution heat losses of 10-15% can be achieved in areas with low-energy houses by cutting the temperature level in half and by doubling the pipeline heat resistances compared to current third generation technology, and by using twin pipes.
4. *Heat supply*: Future heat supply will be more diversified and will give opportunities for power system interaction, renewables, and heat recycling from local excess heat resources. The role

Annex X Final Report: Toward 4th Generation District Heating

of heat storages will increase due to the need to make fluctuating renewables more flexible to satisfy customer heat demands.

5. *Independence*: The case studies were often demonstration areas with installations supported by research grants. They have a high degree of independence achieved by using renewable energy sources and major heat storages. They represent a new market segment for district heating, which has previously been more associated with large-scale citywide systems in concentrated urban areas.

10.5 Heat distribution costs

Both distribution capital cost and distribution heat loss are proportional to the inverse of the heat density. So these two important system parameters depend on a combination of specific heat demands and the concentration of buildings, expressed by the plot ratio. The case studies show that both acceptable distribution capital costs and acceptable distribution heat losses can be achieved for low-energy buildings with low specific heat demands, if these buildings are concentrated. High distribution costs will, however, mean that district heating is not viable for low-energy buildings located in areas with low plot ratios.

10.6 Further comments

The goal of increasing energy efficiency and achieving a wide application of RE brings DH into central focus in the energy supply of the future. Without technical innovation, DH development will be hindered due to the significant building energy reduction and will not be able to compete with on-site heat generation technologies. There is a need to strengthen the competitiveness of DH systems by wider dissemination of best practice, by transferring the knowledge of DH to new generations of DH professionals, and by communicating the advantages of DH to the international community. The aim of this report is to disseminate knowledge of LTDH development and to demonstrate that LTDH is an essential infrastructure if we are to achieve our climate targets with regard to carbon-neutral energy supply, good economy, energy security, and better socio-economic effect. The audiences addressed by this project are engineers, consultants and energy planners, stakeholders, and decision makers. As the main result, the knowledge gathered and experience gained through the project will provide people with the preliminary findings on 4th generation DH and enable them to incorporate the experience learnt in LTDH in their striving to achieve a low-carbon society.

It should be understood that it is a challenging endeavour to implement LTDH on a large scale. A lot of effort will need to be made to realize the concepts in practical engineering practice. The further development of LTDH requires the integration of systematic energy planning with state-of-the-art technology development and envisages energy conservation, the conversion of our fossil-fuel-based energy infrastructure into a renewable-based energy infrastructure, and energy efficiency improvement in a long-term perspective and on a nationwide basis.

List of Abbreviations

CB	Comfort Bathroom
CFU	Colony-Forming Unit (for bacteria)
CHP	Combined Heat and Power
COP	Coefficient of Performance (for heat pumps or CHP plants)
DH	District Heating
DHSU	District Heating Storage Unit
DHW	Domestic Hot Water
DN	Diameter, Nominal
DRY	Danish Reference Year
EPBD	Energy Performance of Buildings Directive
ETFE	Ethylene TetraFluoroEthylene
FAH	Forced Air Heating
FH	Floor Heating
GHG	Green House Gas
GSHP	Ground Source Heat Pumps
HC	Heating Coil
HE	Heat Exchanger
HG	Heat Gains
HP	Heat Pump
HTDH	High-Temperature District Heating (second generation)
IEA	International Energy Agency
IHEU	Instantaneous Heat Exchanger Unit
IPCC	Intergovernmental Panel on Climate Change
LTDH	Low-Temperature District Heating (fourth generation)
MTDH	Medium-Temperature District Heating (third generation)
PB	Polybutylene
PE	Polyethylene
PEX	Cross-linked Polyethylene
PN	Pressure, Nominal
PUR	Polyurethane
RE	Renewable Energy
SH	Space Heating

References

- [1] E. Lysen, The Trias Energica: Solar Energy Strategies for Developing Countries, Eurosun Conference, Freiburg, 1996
- [2] EN 253: District heating pipes – Preinsulated bonded pipe systems for directly buried hot water networks, 2009
- [3] EN 15632: District heating pipes – Pre-insulated flexible pipe systems, 2009
- [4] A. Dalla Rosa, The development of a new district heating concept. Network design and optimization for integrating energy conservation and renewable energy use in energy sustainable communities, PhD thesis; Technical University of Denmark, 2012.
- [5] A roadmap for moving towards a competitive low carbon economy in 2050, European Commission, COM(2011)112, March 2011. Available at www.ec.europa.eu/clima.
- [6] H. Lund, B. Moller, B. V. Mathiesen, A. Dyrelund. The role of district heating in future renewable energy systems. *Energy*, 35, pp. 1381-1390, 2010.
- [7] EC. (October 25, 2012). *Directive on energy efficiency, amending Directives 2009/125/EC and 2010/30/EU and repealing Directives 2004/8/EC and 2006/32/EC. 2012/27/EU*: European Commission.
- [8] Transforming on-grid renewable energy markets: A review of UNDP-GEF support for feed-in tariffs and related price and market-access instruments. New York 2012.
- [9] U. Persson, S. Werner, Heat distribution and the future competitiveness of district heating, *Applied Energy* 88 (2011), pp. 568-576
- [10] H. Lund, B.V. Mathiesen. Energy system analysis of 100% renewable energy systems – the case of Denmark in years 2030 and 2050. *Energy* 2009; 34(5):524–31.
- [11] K. Sperling, B. Möller, End-use energy savings and district heating expansion in a local renewable energy system – A short-term perspective, *Applied Energy* 92 (2012), pp.831-842
- [12] Energy Roadmap 2050, European Commission. COM(2011)885. December 2011
- [13] M. Harrestrup, S. Svendsen, Planning of the district heating system in Copenhagen from an economic perspective comparing energy-savings versus fossilfree supply, DHC13, the 13th International Symposium on District Heating and Cooling. September, 2012, Copenhagen, Denmark
- [14] C. Reidhav, S. Werner. Profitability of sparse district heating. *Applied Energy*, 85 (2008), pp. 867-877.
- [15] Udvikling og Demonstration af Lavenergifjernvarme til Lavenergibyggeri, EFP 2007. March 2009.
- [16] P.K. Olsen *et al.* Low-temperature district heating system for low-energy buildings. Presented at the 11th International Symposium on District Heating and Cooling, Reykjavik, Iceland, 2008.

Annex X Final Report: Toward 4th Generation District Heating

- [17] O. Paulsen. Consumer unit for low energy district heating net. Presented at the 11th International Symposium on District Heating and Cooling, Reykjavik, Iceland, 2008.
- [18] H. Li, S. Svendsen, Energy and exergy analysis of low-temperature district heating network, *Energy* (2012); 45(1): 237-246
- [19] www.arcon.dk (July 2012).
- [20] www.builditsolar.com (July 2012).
- [21] X. Yang, H. Li, S. Svendsen, Review of various solutions for avoiding critical levels of Legionella bacteria in domestic hot water system, the 8th SDEWES conference, Dubrovnik, Croatia, 2013
- [22] Rühling, K.; Rothmann, R.: Verifizierung von Sicherheitsabständen zur Zone des Legionellenwachstums. Schlussbericht zum Teilthema des BMWi-Forschungsprojektes FKZ0327831B. download: http://tu-dresden.de/die_tu_dresden/fakultaeten/fakultaet_maschinenwesen/iet/ew/forschung_und_projekte/bericht_legionellen
- [23] Exner, M.: Wasser und Gesundheit. Vortrag, Wasser Berlin 2011; 02 bis 05. Mai 2011
- [24] Nachweis von Legionellen in Trinkwasser und Badebeckenwasser. Empfehlung des Umweltbundesamtes nach Anhörung der Trink- und Badewasserkommission des Umweltbundesamtes. Bundesgesundheitsbl - Gesundheitsforsch - Gesundheitsschutz, 2000 43:911–915
- [25] DVGW. W551 e Trinkwassererwärmungs- und Trinkwasserleitungsanlagen 1993. Bonn, [in German].
- [26] Legionellaavdödning och sänkt tappvattentemperatur (Reduced tap water temperatures and increased Legionella protection, in Swedish). Teknikmarknad, 2011.
- [27] CO₂-reductions in low-energy buildings and communities by implementing low-temperature district heating systems. Demonstration cases in energyflexhouse and boligforeningen Ringgården. Danish Energy Agency, 2011.
- [28] H. Kristjansson. Distribution systems in apartment buildings. Presented at the 11th International Symposium on District Heating and Cooling, Reykjavik, Iceland, 2008.
- [29] M. Schroeder, S. Svendsen, Lavenergijfjernvarme til eksisterende byggeri-Langøværnet, Århus (Low-energydistrict heatingtoexisting buildings-LangøRoad, Aarhus), Internal report, 2011
- [30] EUDP 2008-II, CO₂ reduction in low-energy buildings and communities by implementation of low-temperature district heating systems, 2011
- [31] W. Winter, T. Haslauer, I. Obernberger. Simultaneity surveys in district heating networks: results and project experience. *Euroheat & Power* 30(2001).10, 42-47.
- [32] H. Li, S. Svendsen, District Heating network Design and Configuration Optimization with Genetic Algorithm, *Journal of Sustainable Development of Energy, Water and Environment System*, in Press, 2013

Annex X Final Report: Toward 4th Generation District Heating

- [33] H.I. Tol, S. Svendsen. Improving the Dimensioning of Piping Networks and Network Layouts in Low-Energy District Heating Systems Connected to Low-Energy Buildings: A Case Study in Roskilde, Denmark. *Energy* 2012; 38 (1):276-90.
- [34] H.İ. Tol, S. Svendsen, Determination of Optimal Hydrostatic Static Pressure Level in Low-Energy District Heating Networks. Submitted to *Challenges in Industrial Ecology* 2012.
- [35] H.İ. Tol, S. Svendsen, Effects of boosting the supply temperature on pipe dimensions of low-energy district heating networks: A case study in Gladsaxe, Denmark. Submitted to *Energy and Buildings*.
- [36] District heating piping with plastic medium pipes, status of the development and laying costs. IEA Implement Agreement on DHC, report 1992:P3.
- [37] A. Dalla Rosa, H. Li, S. Svendsen. Method for optimal design of pipes for low-energy district heating, with focus on heat losses. *Energy* 2011; 36 (5):2407-18.
- [38] A. Dalla Rosa, H. Li, S. Svendsen. Modeling transient heat transfer in small-size twin pipes for end-user connections to low-energy district heating networks. *Heat Transfer Engineering* 34(2012):4, pp. 372-384.
- [39] M.Brand, A. Dalla Rosa, S. Svendsen. Energy Efficient and Cost-Effective In-House Substations Bypass for Improving Thermal and DHW Comfort in Bathrooms in Low-Energy Buildings Supplied by Low-Temperature District Heating. Accepted by *Energy*.
- [40] B. Möller, H. Lund, Conversion of individual natural gas to district heating: Geographical studies of supply costs and consequences for the Danish energy system, *Applied Energy* 87 (2010) 1846–1857
- [41] Varmeplan Danmark (“Heat Plan Denmark”, in Danish). Rambøll Denmark A/S and Aalborg University; 2008.
- [42] E. Zvingilaite, T.S. Ommen, B. Elmegaard and M.L. Franck, Low temperature district heating consumer unit with micro heat pump for domestic hot water preparation, DHC13, the 13th International Symposium on District Heating and Cooling, Copenhagen 2012.
- [43] H. Li, S. Svendsen. Energetic and exergetic analysis of low and medium temperature district heating network integration, 2nd International Exergy, Life Cycle Assessment, and Sustainability Workshop & Symposium (ELCAS2) 19 - 21 June, 2011, Greece.
- [44] C.H. Christiansen *et al.*, Results and experiences from a 2-year study with measurements on a new low-temperature district heating system for low-energy buildings. 13th International Symposium on District Heating and Cooling, Copenhagen 2012.
- [45] W. Dallmayer, J. Kuckelkorn, M. Radspieler, M. Reuß, W. Schölkopf, C. Schweigler, L. Staudacher: „Begleitforschung Solare Nahwärme Am Ackermannbogen in München - SNAB– Abschlussbericht“, ZAE Bayern, Garching, October 2010.
- [46] T. Onno *et al.*, Distributed Solar Systems Interfaced to a District Heating System that has Seasonal Storage. IEA Implementing Agreement on DHC/CHP, Annex IX report, 8DH-11-04, 2011.

Annex X Final Report: Toward 4th Generation District Heating

- [47] B. Sibbitt *et al.*, The Performance of a High Solar Fraction Seasonal Storage District Heating System – Five Years of Operation. *Energy Procedia* 30(2012), 856-865.
- [48] Drake Landing website, <http://www.dlsc.ca/>
- [49] S.Frederiksen, S. Werner, District Heating and Cooling. Studentlitteratur, Lund 2013.

Appendix 1. Low-temperature district heating network for newly-built low-energy single family-houses in Lystrup, Denmark

Project background and objectives

The project deals with the integration of sustainable solutions both for the end-user side and the energy supply side⁰. The objectives for the project are:

- Demonstrate the technical and economical feasibility to supply LTDH to low-energy buildings with annual network heat loss below 15-20% of the total delivered heat.
- Test two designs of LTDH substations.
- Evaluate the simultaneity of the heat demand in case of low-energy buildings.

Tabel 1 General project information

General information	
Country	Denmark
City	Lystrup, Århus
Heating degree days ¹	4568
Specific information	
Project initiator /leader	Housing Association Ringaarden
Year of construction/energy renovation	2008-2009 (new construction)
Site area [ha]	1.7
Building units (residential)	40 terraced houses
Number of residents	92 (estimated)
Building units (tertiary)	1 common building
Heated area [m ²]	4115
Plot ratio ²	0.24

¹ (base temperature: 20°C)² built floor area/site area

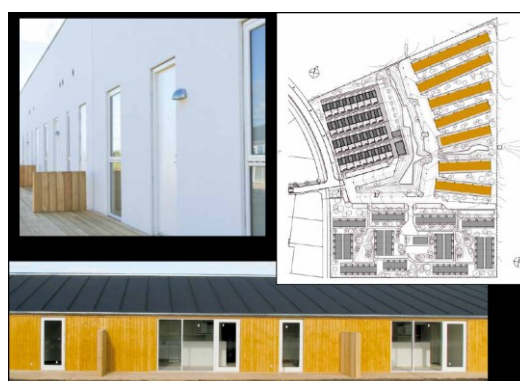

Figure 1 The terraced houses in Lystrup, Denmark and their spatial layout.

Annex X Final Report: Toward 4th Generation District Heating

Technical Description

Heat demand

The Danish Building Regulation 2008, later superseded by the Building Regulation 2010, sets the maximum building primary energy demand for new constructions. There are separate targets for residential buildings (SH, DHW and the electricity use to the related installations, but not including lighting) and non-residential buildings (including lighting). The requirement in residential building is defined as following:

$$E = 70 + 2200/A \text{ [kWh/(m}^2\cdot\text{yr)]} \quad (1)$$

where E is the maximum annual primary energy demand and A is the gross heated area [m²]. The energy requirements also include two classes of low-energy buildings, whose energy demand limit is calculated as follow:

$$\text{Low-energy class 1: } E = 35 + 1100/A \text{ [kWh/(m}^2\cdot\text{yr)]} \quad (2)$$

$$\text{Low-energy class 2: } E = 50 + 1600/A \text{ [kWh/(m}^2\cdot\text{yr)]} \quad (3)$$

The settlement in Lystrup consists of 40 low-energy class 1 terraced houses and a low-energy class 2 building. The calculated primary energy use for SH was 30 kWh/(m²·year). The insulation thickness of the building envelope is as follows: roof, 450 mm; external walls, 335 mm. The U-value of the window is 1.1 W/(m²K). The layout of dwellings consists of seven blocks of houses, divided into two size categories: size C1 (87 m²) and size C2 (110 m²) as shown in Table 1.

Table 1 Building block information

Block number	Total size [m ²]	Number of dwellings	
		Type C1	Type C2
1	771	5	3
2	727	2	5
3	594	3	3
4	528	1	4
5*	479	1	2
6	484	3	2
7	532	6	0

* Including the common building, 170m², low-energy class 2

Annex X Final Report: Toward 4th Generation District Heating

Table 2 Building energy demand

Peak power [kW]	116 (measured)
Total heat demand [GJ/yr]	66 (measured)
Specific heat demand (expected from calculations)	
Specific space heating demand [kWh _{th} /(m ² ·yr)]	30
Specific domestic hot water demand [kWh _{th} /(m ² ·yr)]	13.1*
Total [kWh _{th} /(m ² ·yr)]	43.1
Specific heat demand (calculated from measurements)	
Specific space heating demand [kWh _{th} /(m ² ·yr)]	50.4 (derived)
Specific domestic hot water demand [kWh _{th} /(m ² ·yr)]	7.6
Total [kWh _{th} /(m ² ·yr)]	58

* Based on DHW use of 250 m³/m² and ΔT=45°C, according to the Danish reference software Be06.

Building installations

Space heating installations

The building installations, in terms of heating system, consist of a combination of radiators and floor heatings. The housing type C1 has 4 radiators and the housing type C2 has 5 radiators, which were chosen based on design supply/return temperature of 55/25°C. All the bathrooms are equipped with under floor heating.

Table 3 Characteristics of the radiators installed in the buildings.

Length [mm]	C1: design power [W]				C2: design power				Common house: design power			
	70/40 [*]	60/30	55/25	50/25	70/40	60/30	55/25	50/25	70/40	60/30	55/25	50/25
400	396	254	189	158	396	254	189	158				
500					495	317	236	198				
600	594	381	283	237	594	381	283	237				
800									792	507	378	317
1000	990	634	472	396					990	634	472	396
1400					1386	888	661	554				
1800	2032	1296	962	805					2032	1296	962	805
2000									4516	2880	2137	1788
2200					2484	1584	1176	963				
Tot. [W]	4012	2565	1906	1596	5354	3423	2545	2131	8329	5318	3949	3305

* Supply/return temperature Note: the height of the radiators is 555 mm. The design indoor temperature is 20°C.

Domestic hot water installations

The DHW is prepared by the low-temperature DHW systems described in chapter 4: the low-temperature Instantaneous Heat Exchanger Unit (IHEU) and the low-temperature District Heating Storage Unit (DHSU).

Annex X Final Report: Toward 4th Generation District Heating

Domestic hot water distribution

The layouts of the DHW distribution pipes and the floor plan of the dwellings were carefully designed, so that there is a separate pipe supplying each DHW fixture and the diameter of the pipe is minimized. Consequently, the water content in each DHW supply line, including the volume in the secondary side of the DHW heat exchanger, is kept below 3 L. 3L is the maximum allowable water content that assures safety in relation to the Legionella risk, even without any treatments (thermal, UV-rays or chemical), according to the German guidelines for DHW systems (DVGW, W551).

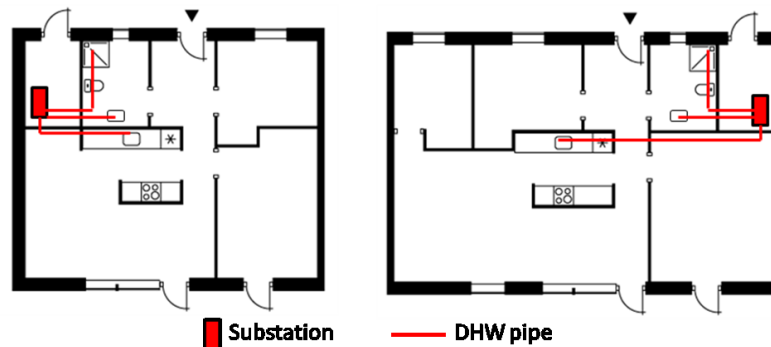

Figure 2 Sketch of the floor plans with the layout of the DHW distribution pipelines. Type C1 (left), type C2 (right).

Heat distribution network

A sketch of the DH network with the location of the main flow meters during the monitoring project is shown here below. Moreover, temperature and flow sensors were placed in each of the in-house substations, as well.



Figure 3 Sketch of the DH network with the location of the meters.

Annex X Final Report: Toward 4th Generation District Heating

Table 4 The main characteristics of the network and the design operating temperatures

Trench length [m]	767
Linear heat density [MWh/(m·yr)]	0.31
Average T_{supply} [°C] (heating season) ¹	55 (design value)
Average T_{return} [°C] (heating season) ²	25 (design value)
Average T_{supply} [°C] (non-heating season)	55 (design value)
Average T_{return} [°C] (non-heating season)	25 (design value)

1. In Denmark, 1st November – 30th April. 2. In Denmark, 1st May – 31st October

Network Dimensioning

The network consists of flexible plastic twin pipes for dimensions up to DN32 and of steel twin pipes for larger dimensions. Heat loss coefficients are calculated according to 0.

Table 5 Pipe specifications. Alx: Aluflex twin pipes; Tws: Steel twin pipes

	Inner diameter	Heat loss coefficients		Roughness [mm]	Length [m]	Estimated cost in 2010 [€/m]	
		$U_{11}=U_{22}$	$U_{12}=U_{21}$			Purchase	Total
Alx 14/14-110	10	0.05	0.035	0.02	123	47	162
Alx 20/20-110	15	0.065	0.037	0.02	221	56	166
Alx 26/26-125	20	0.071	0.049	0.02	155	67	207
Alx 32/32-125	26	0.088	0.053	0.02	130	78	211
Tws-DN 32	37.2	0.085	0.056	0.1	90	82	240
Tws-DN 40	43.1	0.099	0.053	0.1	32	88	246
Tws-DN 50	54.5	0.096	0.06	0.1	16	122	268

The other assumptions for the design were:

- Maximum pressure level: It is beneficial to dimension the network pipeline to exploit the maximum allowable pressure drop. For maximum pressure limit for plastic service pipes is 10 bars. In fact the pipeline systems must by regulations withstand pressures 1.2-1.5 times the nominal value.

- Thermostatic by-pass valves set to 40°C, in the customer's substation at the end of each street line and set to 35°C, in all the other customers' substations.

- Design supply temperature from the heat source: 55°C; design return temperature: 25°C.

- Maximum water velocity: 2.0 m/s.

- Minimum supply/return pressure difference at the end-user's substation: 0.3 bar.

Annex X Final Report: Toward 4th Generation District Heating

Heat sources

The distribution network in this case study is a typical example of how a LTDH scheme can be integrated into an existing network at higher operating temperature. There is no heat source on the site, being the heat provided directly from the main municipal, medium-temperature DH system. The water flow at low supply temperature comes from a mixing shunt, where the water coming from the existing DH network in Lystrup is mixed with the return flow from the local network.

The facility is placed in the common house together with the pumping station. The performance of the mixing loop is controlled by a temperature sensor in the main supply pipe to the local network. Such temperature sensor controls a valve in the return line of the same network. The valve closes the return flow to the existing network and increases the amount of water that is mixed with the supply line, until the set point temperature is reached. The system is shown in Figure 4.

Special R&D topics/issues

Heat demand simultaneity and simultaneity factors

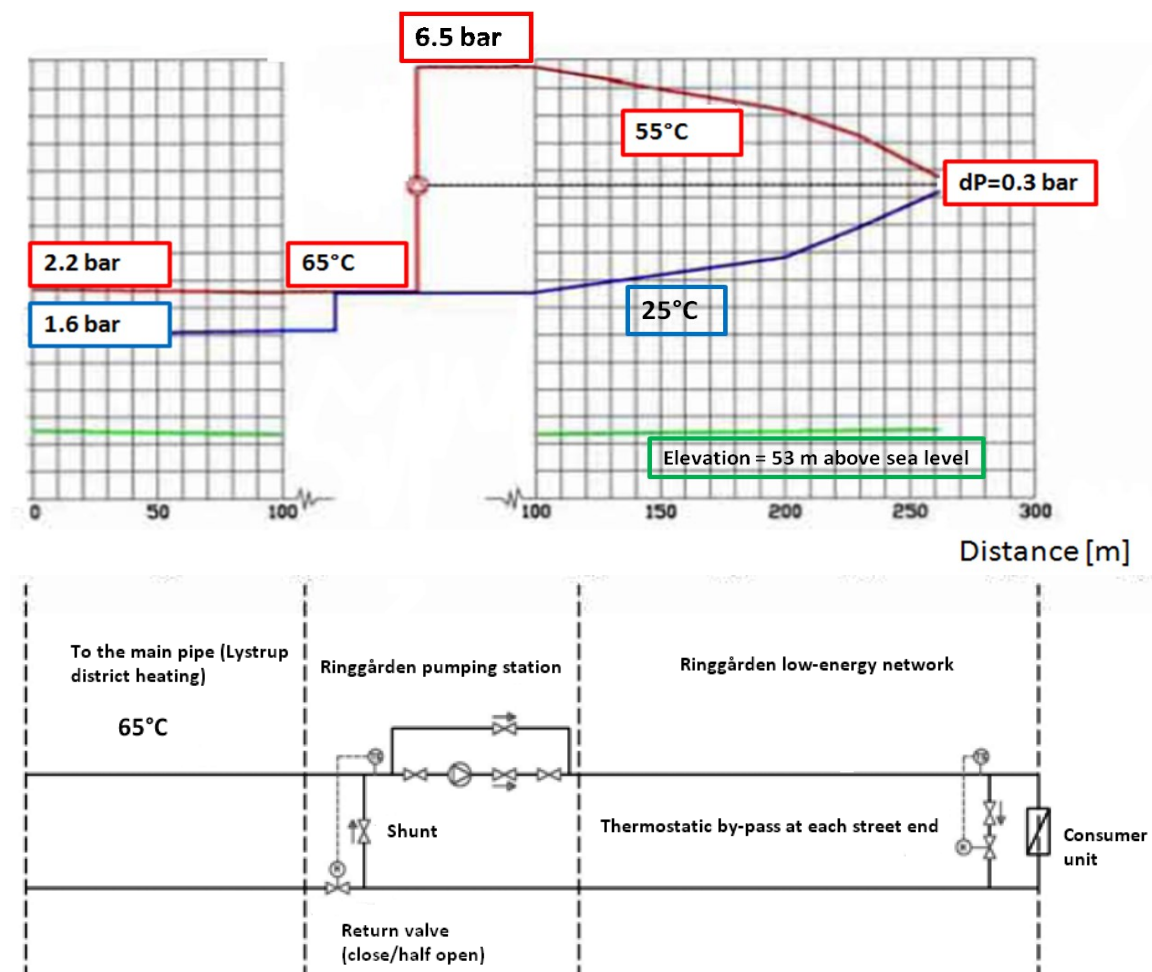

Figure 4 Simplified pressure/temperature diagram of the mixing shunt.

Annex X Final Report: Toward 4th Generation District Heating

During the planning processes the simultaneity factor considered derived from engineering practice in existing networks and buildings belonging to the building stock. The simultaneity factor was assumed to be 1.0 in case of DHSU, due to the low semi-constant flow the unit was designed for. The simultaneity factor for the IHEU depended on the number of consumers instead, according to Table 6.

Table 6 Simultaneity factor s for IHEU vs. number of consumers

Number of consumers	Simultaneity factor	Number of consumers	Simultaneity factor	Number of consumers	Simultaneity factor
1	1.00	5	0.39	9	0.28
2	0.66	6	0.34	10	0.25
3	0.56	7	0.31	20	0.19
4	0.47	8	0.30	30	0.12

There are not any simultaneity factors that have been consolidated by experience for areas with low-energy buildings. Hence, the measurements carried out during the project provide an improved method for designing DH networks in such areas.

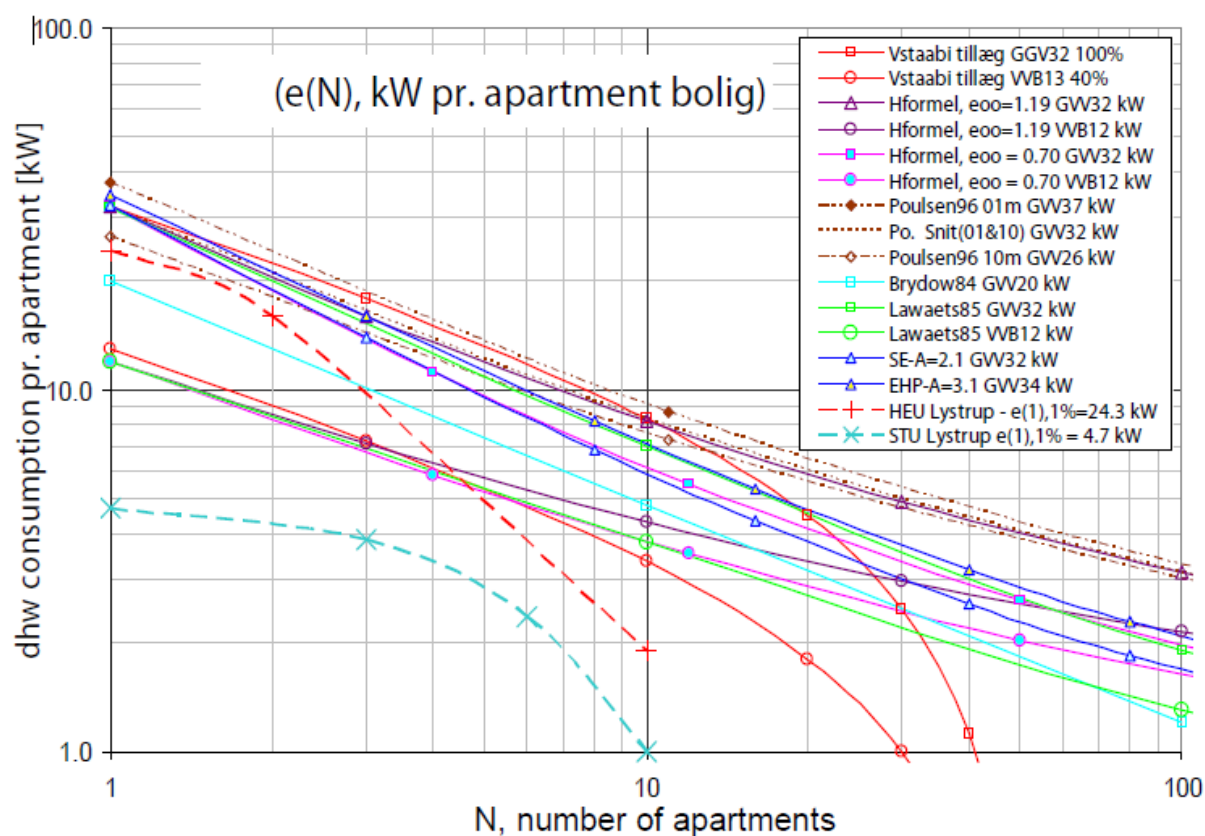

Figure 5 Measured simultaneity factors

Annex X Final Report: Toward 4th Generation District Heating

Based on the monitoring data, curves were plotted for the simultaneity factor up to 10 users, both for the case with IHEU and the case with DHSU. The parameter $e(1)$ corresponds to the heat power of one consumer is 4.7 kW for the DHSU and 24.3 kW for the consumers with IHEU. The parameter $e(1)$ for the case with IHEU is lower than what is usually used in the design, e.g. 32.3 kW in Denmark. On one hand, this result must be seen in relation to the housing type and inhabitants behaviors. On the other hand, the analysis points the fact that the dimensioning of DH systems need a better basis for simultaneity factors and that in future a greater consideration must be given to the installations types, for the calculation of the optimal size of the heat distribution system.

Additional energetic aspects

(implemented measures reducing the heat demand, or targeting energy-efficiency heat generation and distribution, or RE exploitation; other...)

Planning principles and implementation strategies

Applied energy models/tools

The design and simulation of the network was carried out with the commercial software Termis.

Tools used for energy monitoring

An extensive monitoring program was established; the measurements were conducted during the weeks 26-47, 2010.

Energy demand and operating temperatures

The measurements of the indoor temperature in individual homes suggest that a room indoor temperature of at least 22°C should be assumed in the calculation of the heating demand.

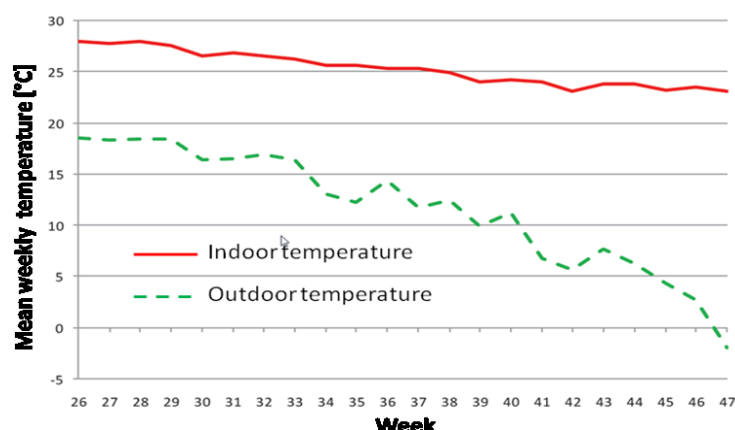

Figure 6 Outdoor temperature and mean weekly indoor temperature in the 41 buildings.

Based on the measurements in the monitoring period, the average annual heating demand per dwelling was estimated to approx. 5.8 MWh for the reference year, corresponding to a

Annex X Final Report: Toward 4th Generation District Heating

measured heat density of 0.31 MWh/m and a heat density of 14 kWh/m². The analysis of the measurements of the actual heat demand show that in the case considered there is a higher heat use for SH than expected. The main reason is that the indoor temperature was kept in average 2-3°C above the set point temperature of 20°C.

The results show that it is possible to supply the customers with a supply temperature of approx. 50°C, with a DH supply temperature at the shunt site 56°C, at maximum.

The average DHW use was measured to be 65 L/(day·house). It is a low value, which is probably related to the number of occupants and their composition (mainly senior persons). Based on an estimation of the number of residents in the dwellings, it is assessed that the DHW use was equivalent to approx. 28 L/(day·person). It should be noticed that the average cold water temperature was approx. 15°C and the average DHW temperature was 40-45°C, giving an average temperature difference of 25-30°C. Literature's estimation suggested instead an average DHW use of 30-40 L/(day·person) and a temperature difference of approx. 40°C, values that in the case study would give an expected heat demand for DHW of 11.8-15.8 kWh/(m²·yr).

The measures demonstrated that DHW can be produced at temperature of just 3°C below the primary supply temperature, e.g. 47°C at a DH supply temperature of 50°C.

The average annual SH demand, the heat loss in the distribution network and the annual electricity use of the pump were calculated based on duration curves divided in 8 representative intervals and the measured data plotted Figure 7.

The results are as follows:

- Total heat production: 287,211 kWh
- Heat demand: 238,070 kWh
- Heat loss: 49,141 kWh (17.1% of the total heat production)
- Electricity use: 2,585 kWh

The measured heat loss for the entire network is in line with the expected heat loss calculated in the design phase and comparable with the present share of the heat loss in the existing city-wide distribution network. The heat losses in the low temperature network are approx. ¼ of the estimated heat loss in the case of conventional medium-temperature network (80/40°C). The electricity use for pumping was estimated to be 2,600 kWh/yr and equivalent to 9 kWh_{el}/MWh_{th}. This is comparable with the electricity demand for pumping purposes in existing well-established systems, being the average electricity demand for pumping in the Danish DH systems 9.9±6.7 kWh_{el}/MWh_t. According to the design method, it was expected to measure a greater pumping demand. The lower electricity use for the pump is explained in practice by the fact that the pressure levels in the network were still well below the limits set. This points out that there is room for optimizing the network design, so that the heat loss can drop significantly at expenses of an additional, but less significant pumping demand.

Annex X Final Report: Toward 4th Generation District Heating

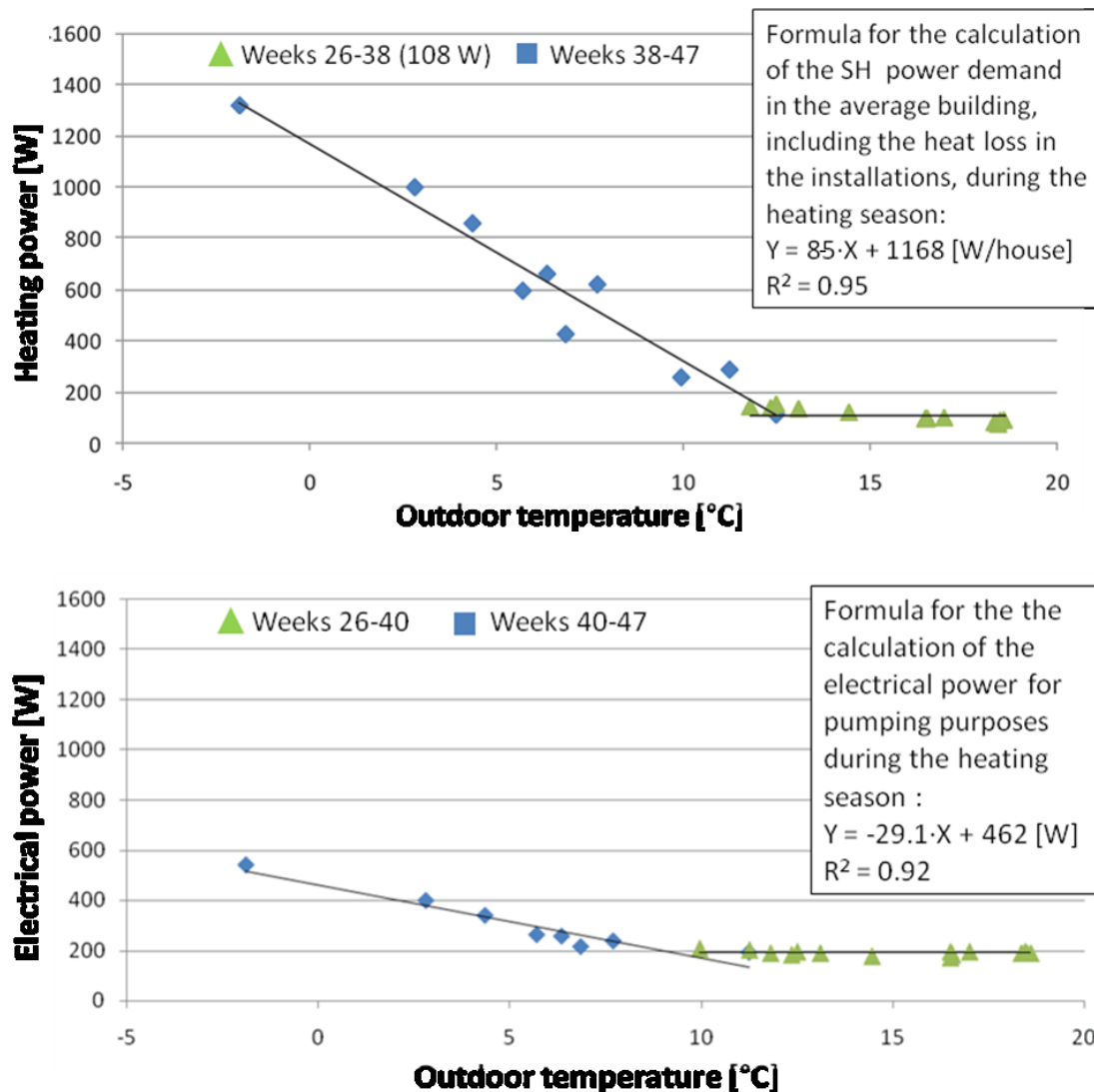

Figure 7 Heating and electricity power at different periods

The 11 homes with DHSU, the average return temperature was 39.4°C in the weeks 26-47; in summer – weeks 26-38 – the average return temperature was 43.6°C. The high return temperature was primarily due to the malfunction of a single unit. The best performing DHSU registered a return temperature of 29°C in summer. The 11 homes with IHEU, the average return temperature was 34.7°C in the weeks 26-47; in summer – weeks 26-38 – the average return temperature was 40.3°C. The high return temperature was primarily due to 2 units, where the control valves were defected and allowed a relative large amount of water to flow uncooled to the return pipe. The best performing IHEU registered a return temperature of 26°C in summer.

The results demonstrate that it is possible to guarantee very good operation, but it is very important to obtain the proper functioning in each substation. Otherwise it will result in unacceptable return temperatures.

In general, the return temperature in the heating season (week 39-47) was lower than in the heating season, which confirms that the radiators delivers low return temperatures (28-

Annex X Final Report: Toward 4th Generation District Heating

33°C). This occurred although the indoor operative temperatures during operation (22-23°C), which were higher than the design conditions (20°C) set a higher limit to the minimum achievable return temperature.

The demonstration project showed that the LTDH concept works well in this pilot project and was confirmed by the fact that there had no complaints from residents due to the system change.

Table 7 Costs for the low-temperature DH network and related installations.

Costs (2010)			
Item	[€/m]	Nr. of unit	Total
Pipes*	120		65,000
Pipe fittings*	32		17,000
Pipe laying**	131		100,500
DHWS Unit*		3,700	41,000
IHE Unit*		2,600	78,000
Unit installation**		1,000	41,000
Pump + frequency controller*		2,400+2,000	4,400
		Total Cost	346,900

* Real cost in the project.** Calculation cost from national average data in Denmark.

Cost figures / Financial set-up / Incentives

The Danish Energy Authority financed the project and therefore funds were made available for R&D purposes. It partly covered the investment costs for designing and implementing the low-temperature DH network as shown in Table 7.

SWOT Analysis

	Helpful to achieving the objective	Harmful to achieving the objective
Internal origin	<p><i>Strength</i></p> <ul style="list-style-type: none"> - Low-temperature operation - Use of advanced technologies (prototypes) - R&D funds from the Energy Authority 	<p><i>Weakness</i></p> <ul style="list-style-type: none"> - Constant supply temperature during the year (no supply temperature boost during peak loads) - Use of advanced technologies (prototypes) - Failure in the functioning of some substations - Insufficient or no insulation of the substations and connection pipes

Annex X Final Report: Toward 4th Generation District Heating

External origin	<p><i>Opportunities</i></p> <ul style="list-style-type: none"> - Vicinity to an existing medium-temperature DH network - Construction of the DH network in parallel with the buildings - Involvement of best available expertise 	<p><i>Threats</i></p> <ul style="list-style-type: none"> - No heat zoning in case of settlements with low-energy buildings - Limitations in the amount of investments available for the project
-----------------	---	---

Conclusions and lessons learnt

The demonstration project of a LTDHsystem shows that it is possible to supply the customers with a supply temperature of approx. 50°C to satisfy both the SH requirements and the safe provision of DHW. This is confirmed by the fact that there were no complaints from residents about the lack of heat or DHW due to low network supply temperature. The energy efficiency target was met with the annual network heat loss equal to 17% of the total heat production.

The duration of the non-heating season is longer in low-energy buildings than in existing buildings. This points out that the importance to optimal operate of by-pass system which otherwise may result in larger impact on the energy performance of the system than that in traditional systems. This is strengthened by the fact that in low-energy buildings it is expected that the heat demand for DHW could generally be very well comparable to the demand for SH. Nevertheless, the measures in the case study points out that the users' behavior strongly affects the heat demand structure.

In DH networks of this kind, serving low heat density areas with no requirement to extend the network in the future, the network dimensioning should envisage the exploitation of the maximum pressure that can be withstood by the media pipes. The network design method can thus be optimized, so that the distribution heat loss can be reduced significantly, at expenses of an additional, but less significant pumping demand.

The analysis points out the fact that the dimensioning of DH systems need a better basis for simultaneity factors and that a greater consideration must be given to the operation of the SH and DHW installations, for the calculation of the optimal size of the heat distribution system.

The results demonstrate that it is possible to guarantee an energy-efficient operation, but it is very important to obtain the proper functioning in each substation, otherwise unacceptable return temperatures result.

Annex X Final Report: Toward 4th Generation District Heating

The measurements showed that the total distribution network heat loss for IHEU is marginally larger than that of the DHSU. This is due to the fact that the additional heat loss from the storage tank itself counteracts the reduction of the distribution heat loss. This indicates that the heat loss from the storage tank unit should not be neglected. The DHSU should be well insulated, in particular if they are placed in a room that is not provided with a ventilation system with heat recovery.

Though DHSU offers some advantages as smaller service pipe diameter and capability to shift the peak DHW load, the optimal storage capacity and its operation should be justified with considering the overall energy performance.

References

- [1] Udvikling og demonstration af lavenergifjernvarme til lavenergibyggeri (Development and demonstration of low energy district heating for low energy buildings, in Danish); Energystyrelsen, 2009.
- [2] Walleen, P. Steady-State Heat Loss from Insulated Pipes, 1991, Thesis, Lund Institute of Technology, Sweden.
- [3] CO₂-reductions in low-energy buildings and communities by implementing low-temperature district heating systems. Demonstration cases in energyflexhouse and boligforeningen Ringgården. Danish Energy Agency, 2011.

Appendix 2. District heating for space heating (SH) and domestic hot water (DHW) demands in multi-family passive houses at Hertings gård in Falkenberg, Sweden.

General description

Project background and objectives

The background for the multi-family passive house project at Hertings gård originates in the *Energy in Minds* project of the Concerto initiative, co-funded by the European Commission within the sixth Framework Programme [1]. The municipality of Falkenberg represented Sweden in the four-year project (2006-2009) as one of four participating municipalities/energy regions in Europe⁷. General aims of the Concerto initiative were to support local communities in developing concrete measures to minimize energy use and to improve quality of life for community citizens. According to the Concerto initiative specifications, the main objective of the Hertings gård project was to build eco-dwellings by use of easily integrated energy measures that would prove acceptable on a large scale and significantly exceed traditional Swedish building code with reference to energy performance [2]. For general information about the Hertings gård multi-family passive house project, see Table 3.

Table 3. General information about the Hertings gård multi-family passive houses in Falkenberg, Sweden

General information		
Country	Sweden	
City	Falkenberg	
Heating degree days ¹	3577	
Specific information		Unit
Project initiator /leader	Falkenberg Bostads AB (FaBo)	
Year of construction/energy renovation	November 2008 – April 2010	
Site area	1.4 (estimated)	ha
Building units (residential)	Four multi-family passive houses	
Number of residents	240 (estimated)	n
Building units (tertiary)	-	
Heated area	10208	m ²
Plot ratio ²	0.73	1

¹ Base temperature: 17°C.

² Built floor area/Site area (in this case: Heated area/Site area).

⁷ Other participants in the Energy in Minds-project were: (i) the energy region of Weiz-Gleisdorf, Austria, (ii) the city of Zlin in the Czech Republic, and (iii) the city of Neckarsulm, Germany. Project activities were coordinated by the Steinbeis-Transferzentrum EGS in Stuttgart, Germany. Two observer communities, Provincia di Torino in Italy and Gornji Grad in Slovenia, were also integrated in the project.

Annex X Final Report: Toward 4th Generation District Heating

The multi-family passive houses of Hertings gård were built by the local municipal housing company Falkenbergs Bostads AB (FaBo). FaBo, apart from the Concerto initiative specifications, added additional project objectives among which passive house standard for all buildings was the first. Other FaBo objectives were (i) comfort floor heating in apartment entrances and bathrooms, (ii) possibility for individual heating of supply air (each apartment has the possibility to independently set the temperature level of the heat supply air), and (iii) individual metering of hot and cold water use. When the project was finalized in the spring of 2010, four identical multi-family passive houses - all connected to the city district heating network of Falkenberg town for base load heat supply - were completed at the 1.4 ha ground site. Additionally, four two-floor houses consisting of four flats each, three new constructions and one reconstruction, were also included in the project although these are not considered in this case study.

Images and location

The four identical multi-family passive houses at Hertings gård are constructed as tower blocks with eight floors each and 27 apartments per building. At ground level, storage and technique rooms allow for only one apartment. Floors 2-7 consist of four apartments each and the top level, floor 8, houses two apartments. All apartments are corner flats with glassed-in balconies. Two different views of the Hertings gård multi-family passive houses are presented in Figure 7.



Figure 7. All four Hertings gård multi-family passive house buildings viewed from south-east (left). Building 18 viewed from south-west (right). Photos: D. Nilsson in [3].

The four multi-family passive house buildings of the Hertings gård project were built in two stages, where building 18 and 19 were completed in the autumn of 2008, and building 16 and 17 were finalised two years later in early spring of 2010, see Table 4. For reference on building numbers, see Figure 9 below. According to [2], the resident density was initially anticipated to 2.2 persons per apartment, which would imply a total occupancy of approximately 240 residents within the whole settlement. By this estimate, a specific residential building space of 32 m²/resident could be expected when referring to residential living areas only (7700 m²). If considering total heated area of the settlement (10208 m²), the equal estimate would be approximately 42 m²/resident.

Annex X Final Report: Toward 4th Generation District Heating

Table 4. Building data of the multi-family passive houses at Hertings gård in Falkenberg. Source: [2]

Building	Access	Heated area	Res. living area [m ²]	Nr. of floors	Nr. of apartments
Building 16	March 2010	2552	1924.8	8	27
Building 17	February 2010	2552	1924.8	8	27
Building 18	December 2008	2552	1924.8	8	27
Building 19	November 2008	2552	1924.8	8	27

The municipality of Falkenberg is one of six municipalities within the Swedish administrative unit of Hallands län (SE231 in the NUTS3 region classification). In all, Hallands län covers a land area of 5720 km²[4] and hosts a total population of 301724 residents (December 31st, 2011 [5]), rendering a general population density of approximately 53 residents per square kilometre, see Figure 44. The municipality of Falkenberg stretches over a land area of 1109 km²[6] and its population density is approximately 37 residents per square kilometre. In the town of Falkenberg the total population reached 20035 residents on the 31st of December 2010, equalling a population density of 1349 residents per square kilometre, given a town land area of 14.85 km²[7].

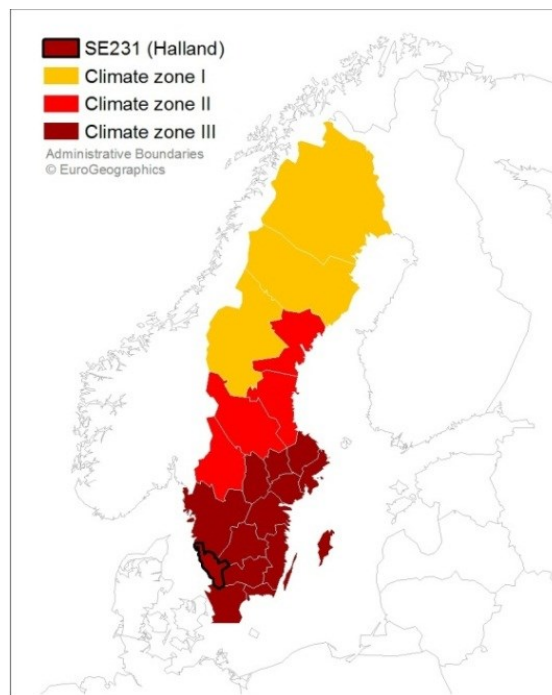

Figure 44. Swedish climate zones as defined in BBR 2012. NUTS3 region SE231 (Hallands län) marked by black perimeter. Source: [8].

Regulations for construction of new buildings in Sweden are assembled in a reoccurring publication from the Swedish housing agency (Boverket). In the latest version, the 2012 set of construction regulations (Regelsamling för byggande, BBR 2012 [8]), three climate zones are used to distinguish between northern, central, and southern regions of the country (Figure 44). As can be seen in

Annex X Final Report: Toward 4th Generation District Heating

Table 5, general requirements with respect to specific energy use for new constructions⁸ are allowed to increase with increasing latitude. In climate zone III, where the municipality of Falkenberg is situated, the corresponding level of specific energy use is set to 90 kWh/m² heated area and year, for any new construction supplied with energy from non-electric alternatives. For electrical energy supply options, the levels are markedly reduced.

As regards to the passive house concept, no formal regulations on specific energy use exist in Sweden today. But, recommendations have been assembled by the *Forum för Energieffektiva Byggnader* (FEBY, Forum for energy efficient buildings), which comprises an experienced work group with support from, among others, the Swedish Energy Agency. In the publication [9], corresponding levels of recommended specific energy use in passive houses are defined, see

Table 5. From these it is evident that passive houses are expected to meet energy demands for SH, DHW, and building electricity (BE), by much lower supply levels compared to ordinary buildings. In the context of this case study, the term “low-energy” district heating implementation is hence deliberately chosen in the heading, to distinguish between pure low-temperature district heating applications and conventional district heating technology in conjunction with low-energy buildings.

Table 5. Swedish standards of specific energy use for SH and DHW by three climate zones; BBR 2012 national regulations for new constructions and FEBY 2009 recommendations for Swedish passive houses

Climate zone	Zone I	Zone II	Zone III	Unit
BBR 2012 (Residential buildings)				
Spec. Energy use	130	110	90	kWh/m ² heated area, year
Spec. Energy use – electric heating	95	75	55	kWh/m ² heated area, year
FEBY 2009 (Residential and school buildings - recommendations)				
Spec. Energy use	58	54	50	kWh/m ² heated area, year
Spec. Energy use – electric heating	34	32	30	kWh/m ² heated area, year

The principal site plan of the Hertings gård multi-family passive house ground site is presented in Figure 9. The settlement is located approximately two kilometres from the Falkenberg city center (approximately at 56.9° N, 12.5° O), from where a 1.5 kilometre twin district heating pipe is connected.

⁸ The sum of all bought energy for SH, DHW, and building electricity (BE) demands, not including household electricity (HE). Building electricity (BE) referring to electricity for e.g. circulation pumps, fans, common appliances and lighting.



Figure 9. Principal overview of the Hertings gård multi-family passive house ground site (with numbering of each building). Source [10].

Technical description

The term “passive” in the passive house concept refers to the relatively enhanced dependency on internal heat contributions to meet total heat demands of a building. Internal heat contributions, originating in the use of e.g. electrical appliances, human activities, solar irradiation etc., constitute a higher share of the total heat supply in passive houses compared to ordinary buildings, why thermal comfort in passive houses is more sensitive to resident behavior.

Two basic principles of passive houses are (i) massive insulation (low transmission losses) and (ii) high degree of air-tightness, both acting to minimize energy losses through the building envelope. One important consequence of these principles is that in-door surface temperatures remain close to room temperatures, why thermal comfort can be maintained without the use of traditional radiators [3]. Instead, the use of controlled air systems are frequently seen in passive houses, which by additional exhaust air heat recovery contributes to further reducing the need of external heat supply. According to Swedish passive house recommendations, as expressed by FEBY [9], the use of controlled air systems with exhaust air heat recovery is in principle mandatory, although exceptions from this are accepted on the basis of geographical location.

Annex X Final Report: Toward 4th Generation District Heating

In the case of Sweden, the two basic principles of passive houses are expressed quantitatively by a specified heat transfercoefficient demand for windows not exceeding $0.90 \text{ W}/(\text{m}^2\text{°C})$. From practice, a general average building envelope heat transfercoefficient of $0.1 \text{ W}/(\text{m}^2\text{°C})$ is common in Swedish passive houses. Regarding building envelope tightness, the FEBY specifications indicate maximum air leakages at $\pm 50 \text{ Pa}$ pressure difference to no more than $0.30 \text{ dm}^3/(\text{sm}^2)$. Initial testing at Herting gård measured an average air leakage of only $0.16 \text{ dm}^3/(\text{sm}^2)$ for the successfully built multi-family passive houses in the project [2].

The four multi-family passive houses are built on flat plates upon the ground with a supporting concrete construction of floors, inside walls, stair-cases and elevator shafts. The non-supporting outer walls are fitted with 395 mm of insulation, rendering an average outer wall heat transfercoefficient of $0.1 \text{ W}/(\text{m}^2\text{°C})$. Equivalent heat transfercoefficients for both ground floor and roof is $0.08 \text{ W}/(\text{m}^2\text{°C})$. Compared to standard passive houses in central Europe, e.g. in Germany and Switzerland, where corresponding k-values often range from 0.11 to $0.25 \text{ W}/(\text{m}^2\text{°C})$ [3], the heat transfercoefficient values from the Swedish example indicate an a adaption to colder seasonal climate.

Heat demand

A critical issue often noted in relation to passive houses and district heating is the potential conflict of high investment costs for network heat supply, and the relatively low heat demands of passive houses. Expansions of district heating systems are dependent on heat distributors being able to achieve feasibility on the basis of heat sales, which might be hazardous in areas with low-energy housing [11]. Personal communication with the manager of district heat sales at Falkenberg municipal energy company, FEAB [12], also revealed that this was an initial issue regarding the Hertings gård multi-family passive houses upon connection to the FEAB district heating grid. In short, early communications regarding the level of installed district heat supply capacity and expected annual heat sales failed in parts, amounting in connection fees being set too low to reflect actual cost levels of network investments.

Still, from the perspective of energy efficiency and the key property of district heating systems to recover and distribute excess heat that would otherwise be wasted [13], district heat represents a strategic and environmentally beneficial solution, in comparison to fossil fuels and electricity being directly used to satisfy low temperature residential and service sector heat demands. As such, passive houses – and especially multi-family passive houses – could ideally add value to the operation of future district heating systems, by acting as temporal thermal heat storages to level out shorter periods of peak heat demands [3]. In a development with larger proportions of low-energy houses with high thermal inertia connected to traditional district heating systems, reduced demand for investments in peak generation facilities could improve the economy of 3rd generation network heat distribution. By the reduced supply and return temperatures associated with the 4th generation of district heating – and the subsequent possibility to use alternative and less costly pipe materials – these features of low-energy buildings are likely to gain in importance.

In each of the multi-family passive houses of Hertings gård, a ground floor technique room houses the district heating sub-stations. Each building is connected at a heat capacity of 46

Annex X Final Report: Toward 4th Generation District Heating

kW for SH, and at 132 kW for DHW⁹, see Table 6. Unique for these buildings is also a solar air installation in each building, which utilises the principle of pre-heating inlet air by close passage to the (partially solar heated) building envelope in specially designed channels (see also section “Building installations” below). In specific energy terms, these solar air installations contribute with an additional 2.6 kWh/m² heated area per year, which constitute an approximate 17% share of the district heating SH demand.

Table 6. Heat loads and energy demands for SH and DHW at the multi-family passive houses of Hertings gård in Falkenberg. Source [14]

Heat loads and energy demands	Value	Unit
Peak power SH - per building	46	kW
Peak power DHW - per building	132	kW
Peak power SH - all four buildings	184	kW
Peak power DHW – all four buildings	528	kW
Total heat demand SH & DHW - per building ¹	93517 (measured)	kWh/year
Total heat demand SH & DHW - per building ¹	337 (measured)	GJ/year
Total heat demand SH & DHW - all four buildings ¹	374068 (measured)	kWh/year
Total heat demand SH & DHW- all four buildings ¹	1347 (measured)	GJ/year
Specific heat loads and energy demands	Value	Unit
Specific SH demand – DH ¹	15.3 (measured)	kWh/m ² heated area, year
Specific SH demand – Solar ¹	2.6 (measured)	kWh/m ² heated area, year
Specific DHW demand – DH ¹	18.8 (measured)	kWh/m ² heated area, year
Total SH & DHW demand ¹	36.7 (measured)	kWh/m ² heated area, year

¹ Average values from measurements in each building.

During the year 2011, the first whole year when all four buildings were in operation, the energy performance, temperature levels, and valve operations, of each building at Hertings gård was gauged by a common web-interfaced control system accessible for monitoring [14]. In Figure 46 the district heat supply load for SH and DHW for all four buildings at Hertings gård, together with a grand total curve, are plotted on a daily basis for this year. During winter (heating season defined as the period from 1st November – 30th April), the average DH supply load ranges typically within an interval between 10 kW and 30 kW per building. During the summer season, the heat supply load for SH and DHW coincides at a relatively constant level of 5 kW, which is the average year-round supply load for DHW. Since the data in Figure 46 is gathered by a resolution of daily average values, instantaneous variations in DHW use are not visible.

⁹The relatively high installed capacity for DHW (132 kW) have been subject for discussions by the author and analysts who have studied the project [3]. It is not clear whether the dimensioning of this capacity was in accordance with defined standards, as it seems to be a result of using -18 °C as dimensioning temperature [12], which is well below the -7.0 °C to be expected for a well-insulated building in Swedish climate zone III, according to DUT₂₀ definitions.

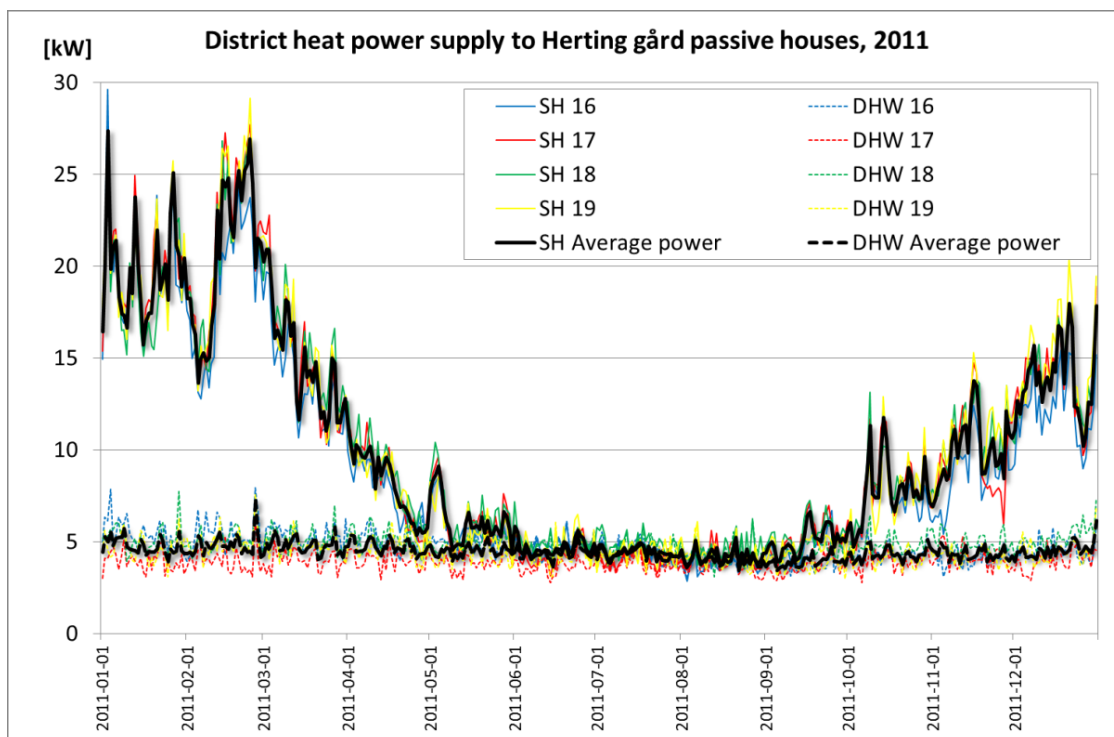

Figure 46. District heat supply load for SH (measured) and DHW (calculated) to building 16, 17, 18, and 19 at Hertings gård in Falkenberg for the year 2011. Source: [14].

It is noticeable how equal in energy performance the four buildings are; an indication of a well carried out construction phase. Note also that additional contribution from the solar air installations on each building is not included in this context. This contribution is most significant during the winter season, with an average daily energy supply in the interval between 25 kWh and 150 kWh per building during this period (peak supply at 260 kWh in March). During summer season, the solar air contribution is practically discarded to avoid over-heating by closing of solar air inlet valves.

Building installations

As previously mentioned, all four multi-passive houses at Hertings gård are built with a load-bearing frame consisting of floors, stair-cases, and elevator shafts. By liberating the outer walls from the load-bearing function, these have instead been constructed as cantilever wooden stud walls, which minimises the risk of thermal bridging through the building envelope [2]. Heat supply to each apartment is provided by means of ventilation air. District heat is supplied through DN40 sized service pipes entering into each buildings technique room at ground level, see **Fejl! Henvisningskilde ikke fundet.** (left), where indirect substations separate the primary supply flow by designated heat exchangers for SH and DHW. In parallel, a central rotating heat exchanger placed in the exhaust ventilation air system, recovers heat from the outgoing air and pre-heats inlet air before secondary heating with district heat, see **Fejl! Henvisningskilde ikke fundet.** (right).



Figure 47. District heat plate heat exchanger sub-station installed at building ground level (left), and installation for exhaust air heat recovery to inlet air (right). Photos: The Author.

After pre-heating by means of heat exchange with exhaust air and contribution from solar heated air, the inlet air-flow is directed through a sub-dividing distributor module, see **Fejl! Henvisningskilde ikke fundet.**, in which a single inlet air supply channel is directed to each apartment in the building. District heat is individually added to each channel of inlet air-flow in a magnitude reflecting the level appointed by the thermostat for desired indoor temperature in each apartment.

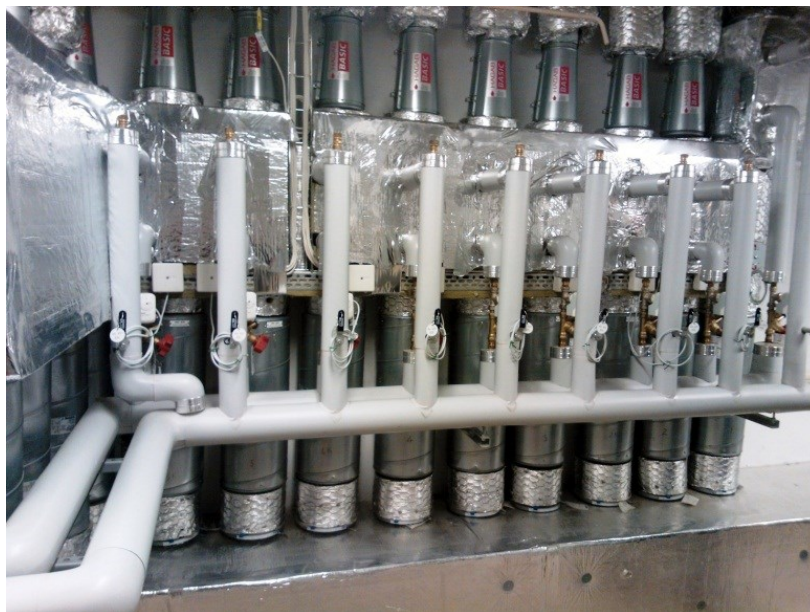

Annex X Final Report: Toward 4th Generation District Heating

Figure 48. Module for individual distribution of heated air to each apartment. District heat supply by heat exchange with each inlet air channel. Photo: The Author.

Annex X Final Report: Toward 4th Generation District Heating

To present the principal configuration of the district heat supply at the multi-family passive houses at Hertings gård, a layout illustration is presented in the form of a screen print from the monitoring system, see Figure 49. Apart from the secondary flow that is directed to the distributor module (LV Fläktrum (1)), a common circuit supplies each apartment with floor heating in bathrooms and apartment entrances (Golvvärme (2)). The expansion function (3) is connected to the suction side of the secondary side main pump (VS11-P1 (7)).

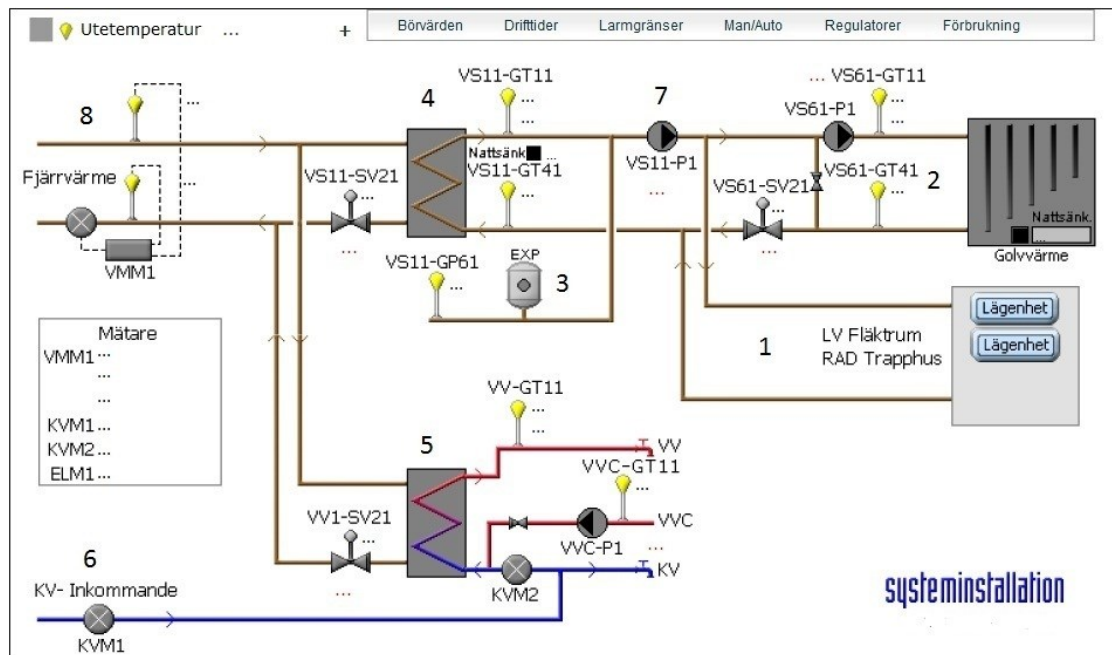

Figure 49. Principal configuration of district heat supply at the multi-family passive houses at Hertings gård in Falkenberg. 1: Secondary flow to distributor module, 2: Common secondary circuit for floor heating, 3: Secondary side expansion function, 4: Heat exchanger for SH, 5: Heat exchanger for DHW, 6: Cold water supply, 7: Secondary side main pump, 8: District heat supply. Source: [14].

The solar air installations installed above the entrance of each building covers 48 m² and are made of perforated steel, see Figure 50. This unique, and low-tech, solution is based on the principle of pre-heating incoming fresh ventilation air by passage through uniform air pipes enclosed in the construction. The ventilation system sucks the incoming air downwards through the pipes, at which heat exchange to solar heated air inside the construction takes place.



Figure 50. Solar air installation mounted above the entrance of building. Photo: The Author.

Heat distribution network

The Hertings gård site is connected to the heat distribution network of Falkenberg town by a 1.5 kilometer long twin DN100 Powerpipe[®] (1), stretching from the city grid at Tullbroskolan (see (2) in upper left corner of Figure 51) in a south-east direction alongside the river Ätran to the remote site location(not included in site network characteristics). At about one third of the distance from the connection point to the Hertings gård site, the distribution pipe is used also to supply district heat to a nursing home (Vårdhem (3)), adding to the total heat load of the connection.

According to personal communication with FEAB [15], the choice of slightly over-dimensioned DN100 distribution pipes were motivated by the possibility of completing a future ring-configuration, as the distribution pipe line to Hertings gård could be extended southward/southwest to re-connect with the city grid as the town district heating system expands (4). An overview of the connecting pipe line to the city network is presented in Figure 51.



Figure 51. Overview of heat distribution pipe line to Hertings gård from Falkenberg city district heating network. Source: [16].

At arrival to the Hertings gård site, the main distribution pipe is down-scaled to twin DN40 service pipes entering each building (5). The thermal heat conductivity of the piping insulation is the same for the DN40 pipes as the main distribution pipe (see Table 7 below). The length of each service pipe is estimated to approximately 20 meters. As can be seen in Figure 51 and Figure 52, the main distribution pipe connects also to two additional heat customers at the site. In these extensions, pipe dimensions of DN50 and DN65 are used before final heat supply in DN40 service pipes.

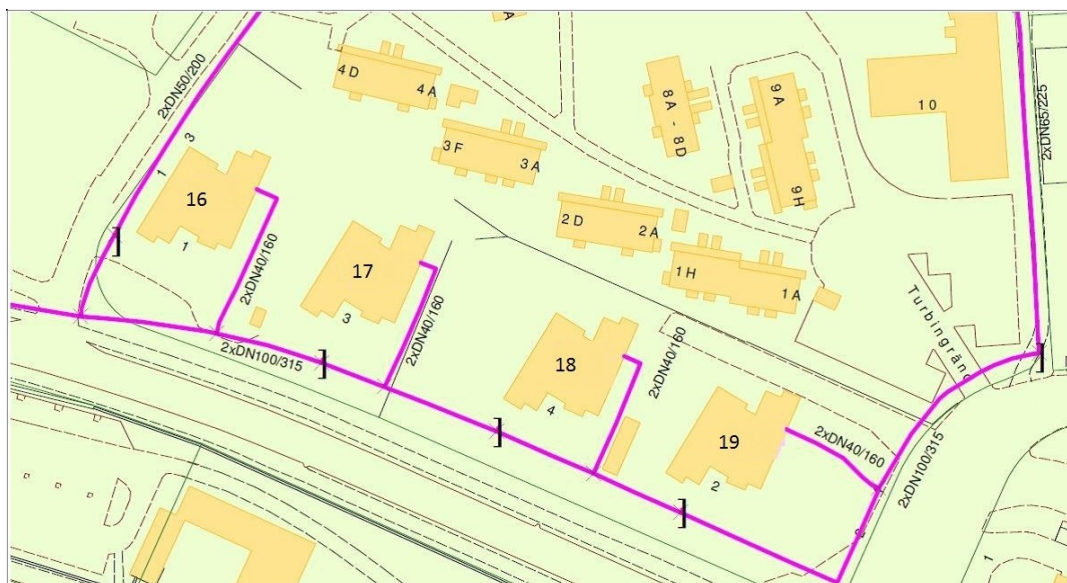

Figure 52. Site heat distribution network at Hertings gård multi-family passive houses in Falkenberg. Source: [16].

The district heating system in Falkenberg town began operation in 1984 and has been expanding rapidly ever since. In 2008, 54.5 GWh of heat was supplied to city customers, of which approximately 9% were single family houses. Heat generation is based primarily on incineration of wooden chips (77%) and bio oil (11%) in eight medium sized boilers ranging from 2.0 MW to 8.3 MW [16], see Figure 53 below. Additional heat generation is fuelled by pellets (8%) and minor shares of natural gas and fossil oil.

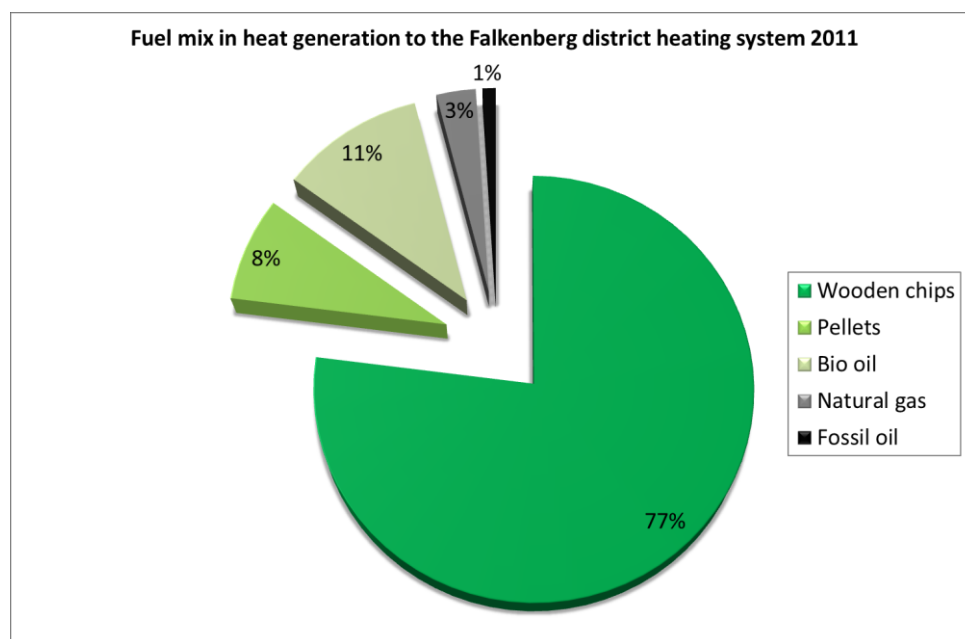

Figure 53. Fuel mix in heat generation to the Falkenberg district heating system in 2011. Source: [16].

As indicated earlier, the district heat supply at Hertings gård multi-family passive houses operates at conventional 3rd generation temperature levels, and is thus not - in a strict sense of the word - an example of low-temperature district heating implementation. Still, the combination of district heat supply to low-energy buildings, be it at medium or low temperature levels, is of general interest since the future of district heating is closely related to the development of thermal performance in the building stock.

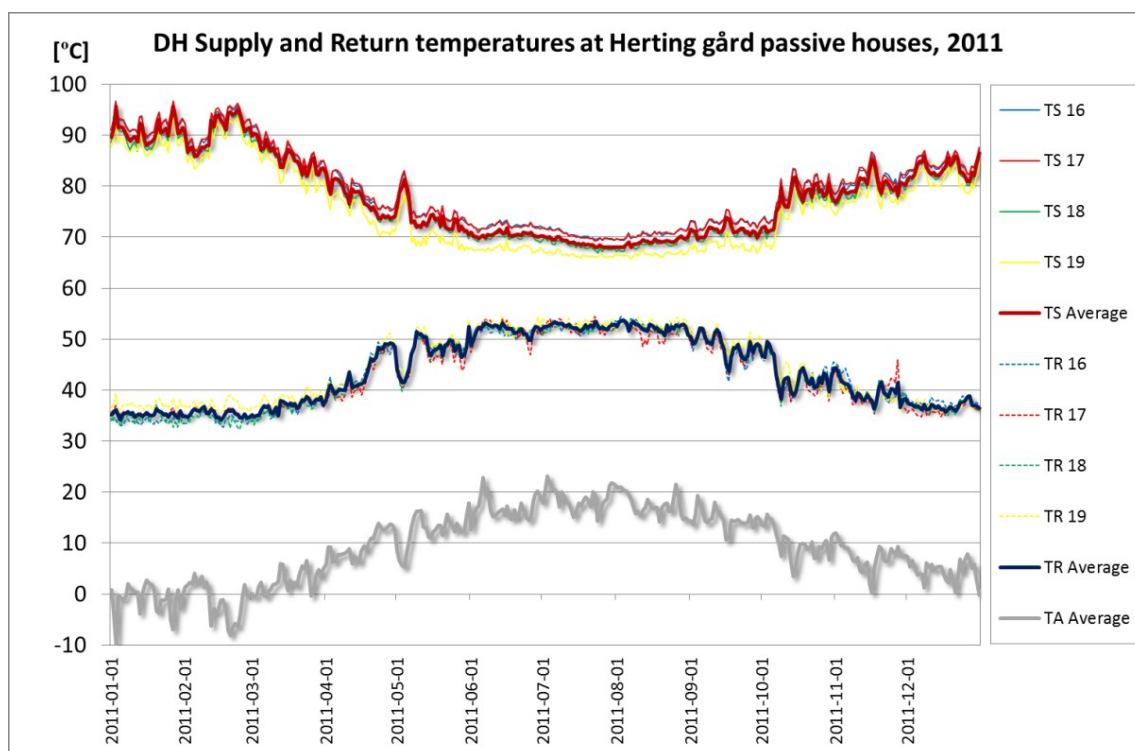

Figure 54. District heat supply and return temperatures at Hertings gård in Falkenberg for the year 2011. Source: [14].

In Figure 54, daily average district heat supply and return temperatures at all four multi-family passive houses at Hertings gård are assembled for the year 2011, together with average ambient temperatures gauged at site. Daily average supply temperatures range from 75 °C to 95 °C during heating season, and remain within a narrower interval between 65 °C to 75 °C in the summer season. Daily average return temperatures are markedly higher in the summer season (pending at 50 °C) than during heating season, where an approximate temperature difference in the interval of 50 °C to 60 °C manages to lower these to 35 °C. Once again, all four building show very similar patterns with regard to supply and return temperatures, why it can be concluded that the operation of sub-stations and ventilation air systems in each building is representative for the site in general.

In the context of the IEA-DHC/CHP Annex X project; Towards 4th Generation District Heating, the work programme is divided into two phases. The first phase aims at assembling a folder of case studies, such as this one, with national examples of low-temperature and low-energy district heating implementations. In the second phase, which is scheduled for the latter part

Annex X Final Report: Toward 4th Generation District Heating

of 2012 and the spring of 2013, the assembled case studies of the first phase will provide information for analysis in search of general and common features characteristic for 4th generation applications. One such feature is the specific investment cost for district heating networks, the distribution capital cost [17]. To provide relevant in-data parameters for such – and other – calculations, it has been proposed during the research process for all case studies to provide information according to the data categories (Quantity) presented in Table 7. In this table, corresponding values for the Hertings gård multi-family passive house project in Falkenberg are presented.

Table 7. District heating input data parameters at Hertings gård multi-family passive houses in Falkenberg. Source: [14] and own estimations as indicated

Quantity	Label	Value	Unit
Trench length	L	342 (estimated)	m
Annually sold heat - total	Q _S	1252	GJ/year
Annually sold heat - total	Q _S	348	MWh/year
Linear heat density	Q _S /L	3.66	GJ/m,year
Linear heat density	Q _S /L	1.02	MWh/m,year
Average pipe diameter ¹	d _a	0.076	m
Thermal conductivity of pipe insulation ²	k	0.026	W/(m°C)
Average supply temperature	T _S	78	°C
Average return temperature	T _R	44	°C
Average ambient temperature	T _A	9	°C
Average supply temperature(heating season) ³	T _{S,hs}	85	°C
Average return temperature(heating season)	T _{R,hs}	38	°C
Average ambient temperature(heating season)	T _{A,hs}	4	°C
Average supply temperature(non-heating season) ⁴	T _{S,nhs}	72	°C
Average return temperature(non-heating season)	T _{R,nhs}	49	°C
Average ambient temperature(non-heating season)	T _{A,nhs}	15	°C

¹Weighted arithmetic mean value of distribution pipe line and service pipes.

²[18].

³ 1st November – 30th April (Denmark, Sweden).

⁴ 1st May – 31st October (Denmark, Sweden).

Planning principles and implementation strategies

Applied urban planning policies/instruments

The multi-family passive house project at Hertings gård was on an initial stage set to fulfill clearly defined targets and ambitions. In short, these ambitions were to use the latest methods and techniques for housing construction in the areas of:

- Energy conservation
- Insulation/building envelope
- High performance windows (low thermal conductivity)
- High performance energy equipment (energy efficient appliances)
- Advanced control and monitoring systems
- Solar air system integrated in the building envelope

Annex X Final Report: Toward 4th Generation District Heating

- Individual metering of domestic energy and water use

Quantified project specifications within these categories were defined within the Concerto initiative and the Energy in Minds project.

Tools used for energy monitoring

Each apartment is equipped with a Smart-box – a small wall mounted computer and information terminal with wireless connection to a centrally placed computer server with system information for:

- Individual metering of water use
- Individual metering of DHW use
- Individual metering of household electricity (HE) use

All heat energy supply and use at the Hertings gård multi-family passive houses are recorded and accessible through the web-interfaced monitoring system provided by REGIN through the EXO4 Web server 2010 [14].

SWOT Analysis

	Helpful to achieving the objective	Harmful to achieving the objective
Internal origin	<p>Strength</p> <ul style="list-style-type: none"> - Strong ambition to achieve efficient housing alternatives to community residents by municipality. - Clearly defined and quantified project specifications regarding energy performance of buildings. - Good planning and outsourcing, well performed construction. 	<p>Weakness</p> <ul style="list-style-type: none"> - No weakness known.
External origin	<p>Opportunities</p> <ul style="list-style-type: none"> - Participation and partial project funding through the Concerto initiative Energy in Minds, under the 6th framework programme. - Cooperation with other external parties, e.g. offering research opportunities for local universities. 	<p>Threats</p> <ul style="list-style-type: none"> - Not fully satisfactory level of initial communication between project management and external heat supplier, regarding expected magnitude of annual heat deliveries and installed heat supply capacity.

Conclusions and lessons learnt

Annex X Final Report: Toward 4th Generation District Heating

The Hertings Gård multi-family passive house project has – technically and in general – provided evidence for the viability of combining extremely low building energy demands for SH with heat supply from conventional district heating. From an energy efficiency viewpoint, the settlement serves as a good example of how future multi-family housing can be designed and constructed, to facilitate high living comfort while simultaneously minimizing energy use. The choice of district heating as heat supply, in the Falkenberg case furthermore generated by a >95% biomass originated fuel mix, allows additionally for a significantly reduced carbon footprint with respect to the required energy supply to satisfy SH and DHW demands in the settlement.

From an economical perspective regarding the feasibility of the district heat supply, which naturally is challenged by the low linear heat density of the remote – and low energy – connection, an important lesson from the project appears to be *clear initial communication between project partners*. The reduced margins for profitability in low energy conventional district heating applications implies enhanced detail in initial project planning and dimensioning of expected heat loads. Revenues from delivered district heat need to be balanced appropriately between initial connection fees (load levels) and the continuous prices on heat sales (energy volumes), a balance depending largely on mutually sincere and precise project partner communication.

References

- [1] Concerto initiative, “Energy in Minds,” [Online]. Available: <http://www.energy-in-minds.de/>. [Accessed 11 06 2012].
- [2] J. Hurtig, “Report-evaluation of multi-storey low energy houses at Hertings gård, Falkenberg, Sweden (Energy in Minds),” Halmstad University, Halmstad, 2010. Available at: <http://www.hh.se/download/18.147a3bde12f0373a11980002601/Report.pdf>.
- [3] D. Nilsson, “Fjärrvärmeanslutna passivhus: Fallstudie av värmelaster och innetemperaturer i fyra flerbostadshus,” Halmstad University, Halmstad, 2012.
- [4] Eurostat, “Area of the regions [demo_r_d3area],” [Online]. Available: <http://epp.eurostat.ec.europa.eu/portal/page/portal/eurostat/home>. [Accessed 01 03 2012].
- [5] Statistics Sweden, “Folkmängd i riket, län och kommuner 31 december 2011 och befolkningsförändringar 1 oktober - 31 december 2011 (population statistics),” [Online]. Available: http://www.scb.se/Pages/TableAndChart___228185.aspx. [Accessed 11 06 2012].
- [6] Statistics Sweden, “Kommunarealer den 1 januari 2012 (km²),” Statistiska Centralbyrån, Stockholm, 2012.

Annex X Final Report: Toward 4th Generation District Heating

- [7] Statistics Sweden, "Tätorternas landareal, folkmängd och invånare per km² 2005 och 2010," Statistiska Centralbyrån, Stockholm, 2012.
- [8] Boverket, "Regelsamling för byggande, BBR 2012 (Regulations for construction, BBR 2012)," Boverket, Karlskrona, 2011.
- [9] FEBY, "Kravspecifikation för Passivhus (Demand specification for passive houses)," Forum för Energieffektiva Byggnader/IVL Svenska Miljöinstitutet AB, Göteborg, 2009.
- [10] FaBo, *Personal communication with Barbro Hammar 12-06-07*, Falkenberg Bostads AB, Falkenberg, 2012.
- [11] S. Lembke, "Passivhus i ett svenskt klimat - en byggnadsfysikalisk riskinventering och erfarenhetssammanställning av befintliga passivhusprojekt," Examination thesis, Institutionen för bygg- och miljöteknik, Chalmers Tekniska Högskola, Göteborg, 2008.
- [12] FEAB, *Personal communication with Karin Becker 12-06-11*, Falkenberg Energi AB, Falkenberg, 2012.
- [13] U. Persson and S. Werner, "District heating in sequential energy supply," *Applied Energy*, vol. 95, pp. 123-131, 2012.
- [14] EXO4 Webserver 2010 Edition 3, Licenced to FaBo, "Regin - the Challenger," [Online]. Available: <http://www.regin.se/>. [Accessed 13 06 2012].
- [15] FEAB, *Personal communication with Anders Andersson 12-06-11*, Falkenberg Energi AB, Falkenberg, 2012.
- [16] FEAB, "Falkenberg-energi.se," Falkenberg Energi AB, [Online]. Available: <http://www.falkenberg-energi.se/fjarrvarme/fjarrvarmesystem-i-falkenberg>. [Accessed 13 06 2012].
- [17] U. Persson and S. Werner, "Heat distribution and the future competitiveness of district heating," *Applied Energy*, vol. 88, pp. 568-576, 2011.
- [18] Power pipe, "Powerpipe.se (Installation instructions Chapter 9)," [Online]. Available: <http://www.powerpipe.se/>. [Accessed 12 06 2012].

Appendix 3. District heating as base load heat supply for space heating (SH) and domestic hot water (DHW) demands in new construction multi-family and pair passive houses at Söndrums Kyrkby in the city of Halmstad, Sweden.

General description

Project background and objectives

The Söndrums Kyrkby multi-family and pair passive house settlement in the city of Halmstad, Sweden, was constructed during a two year period between 2008 and 2010 on behalf of the municipal real-estate company Halmstads Fastighets AB (HFAB). The company, which in 2011 possessed approximately 9800 residential rental apartments[1], had some years prior adopted a general energy efficiency program in which refurbishment of existing buildings and new energy lean constructions were recognized as key priority areas. Upon planning for the Söndrums Kyrkby settlement in late 2007, a dedicated task group within the company visited new construction projects in near-by cities – among which the Hertings Gård multi-family passive house settlement in Falkenberg was the first – to learn and find inspiration in new pioneering building technology projects. Thus, without any prior explicit objective to apply passive house technology in the project, none other than a general ambition to build energy efficient new housing, it was decided that the project would be designed to meet Swedish passive house standards and recommendations. Some general information about the Söndrums Kyrkby multi-family and pair passive house project is presented in Table 8.

Table 8. General information about the Söndrums Kyrkby multi-family and pair passive houses in Halmstad, Sweden. Sources: [2], [3], and own estimations as indicated

General information		
Country	Sweden	
City	Halmstad	
Heating degree days ¹	3577	
Specific information		Unit
Project initiator /leader	Halmstads Fastighets AB (HFAB)	
Year of construction/energy renovation	2008-2010 (new construction)	
Site area	1.2 (estimated)	ha
Building units (residential)	Two multi-family and eight pair passive houses	
Number of residents	96 (estimated)	n
Building units (tertiary)	-	
Heated area	4307	m ²
Plot ratio ²	0.36	1

¹ Base temperature: 17°C.

² Built floor area/Site area (in this case: Heated area/Site area).

As the project ground site was located in close vicinity of an existing district heat main distribution pipe, it was further decided that district heat would be used for heat supplies and, as a consequence of this choice, the first plan drawings of the site consisted of two added

multi-family buildings among eight initially planned ground level pair houses (see Figure 55) – deliberately included to increase the linear heat density of the settlement and thus to improve the feasibility of the district heat supply.



Figure 55. Illustration of the Söndrums Kyrkby settlement site. Source: [3].

At project start-up in 2008, the experienced task group came to introduce an unconventional approach to the purchase of contract work, according to [4]. As a means to secure project buildings to be built in accordance with the passive house standard of the time [5], and to reach a high level of consensus among project staff, consultants, and sub-contractors, three unique project documents were produced and combined in a single project description. The first document, the so called “moisture” document, detailed expected protective procedures during the construction phase to avoid unintentional damp damages. The second document addressed issues of building envelope tightness, and the third document, finally, consisted of a complete energy design analysis of the settlement to be, based on plan-drawings, passive house standards, and available data on dimensions and materials to be used during the construction.

The third document, the energy design analysis, was performed by an independent external energy consultant firm and modeling results were compiled in a report [2]. In the context of this case study, this report constitutes the central source of information regarding the energy performance of the settlement. Since the settlement was not fully habituated until late 2011, no full year operational data sequences for the entire site have up to date been available. Still, some (first) operational data information from the spring of 2012 was recently communicated by the municipal energy company Halmstads Energi och Miljö AB (HEM), the district heat supplier in the city of Halmstad, although in non-edible form why the information is of minor relevance for this study. Additional sources of information consist of various project brochures, site visits, and personal communications with project partners. Hence, the accounts presented and referred to in this case study are a mixture of mainly estimated and

Annex X Final Report: Toward 4th Generation District Heating

calculated, and for a lesser part, registered information about the multi-family and pair passive houses at the Söndrums Kyrkby settlement.

Images and location

As illustrated in Figure 55 and detailed in Figure 56, the SöndrumsKyrkby settlement consists in all of ten passive houses; two five-story multi-family houses (A) and eight ground level pair-houses with two apartments in each (B and C), see also Figure 57 below. The settlement is located approximately 4.2 kilometers from the Halmstad city center and is connected to the city district heating system by connection to a main distribution pipe passing the settlement site at some 100 meters distance. The settlement is further equipped with a car parking area and a centrally placed common green recreational area. The layout of the settlement and the three different kinds of dwellings is presented in Figure 57.



Figure 56.Principal site plan of the Söndrums Kyrkby multi-family and pair passive house ground site. Building types are: (A) Multi-family houses, (B) Pair-houses with a two-room and a four-room apartment, and (C) Pair-houses with two three-room apartments. Source: [3].

All the passive house buildings of the Söndrums Kyrkby project were built and completed during the two year period between 2008 and 2010, and the settlement was ready for limited occupation by the 1st of July 2010. According to own estimates¹⁰, the resident density has been anticipated to 1.7 persons per apartment, which would imply a total occupancy of

¹⁰Based on the assumption that each two-room apartment of the settlement will house one resident on average, each three-room apartment will house two residents on average, and each four-room apartment will house three residents on average.

Annex X Final Report: Toward 4th Generation District Heating

approximately 96 residents within the whole settlement, see also Table 8. By this estimate, a specific residential building space of 45 square meters per resident could be expected when referring to total heated area of the settlement (4307 m²).

By this site configuration, 71% of the total heated area of the settlement is located within the two multi-family buildings, while the relative share of ground area that these two buildings occupy corresponds to less than 25% of all built area on the site. This condition did prove advantageous when district heat was connected to the settlement, since this heat supply option eventually would have had to be discarded if only ground level pair passive houses were to be heated. Another beneficial circumstance regarding the district heat supply to the settlement was that the district heat distributor (HEM) early agreed to distribute heat directly to heat exchanger sub-stations in each project building, which allowed HFAB to eliminate the alternative of installing a settlement heat sub-network for internal heat distribution on site [4]. By this agreement, all distribution heat losses occurring during site heat deliveries are consequently the responsibility of the heat distributor – and not one for the heat customers at the settlement. Additional conditions and information regarding the district heat supply at the Söndrums Kyrkby settlement are further described in section “Heat distribution network” below. In Table 9, some specific information about the Söndrums Kyrkby passive houses are assembled.

Table 9. Specific information about the Söndrums Kyrkby multi-family and pair passive houses in Halmstad, Sweden. Sources: [2] and [3]. It should be noted that apartment areas stated in [2] differ marginally from those given in [3]

Type	Number of buildings	Number of apartments per type (heated floor area in parentheses [m ²])				Count of apartments	Heated floor area [m ²]
		2 rooms	2 rooms	3 rooms	4 rooms		
A	2	4 (57)	8 (61)	7 (82)	2 (120)	42	3060
B	3	-	1 (64)	-	1 (95)	6	477
C	5	-	-	2 (77)	-	10	770
Total	10	8	19	24	7	58	4307

The issue of building envelope tightness, in itself one of three basic characteristics of passive houses (the other two being low thermal transmission and exhaust air heat recovery), were of special interest at project start-up. The dedicated and experienced project task group at HFAB shared a common general interest in this matter, and was eager to learn more through the planning and construction of the Söndrums Kyrkby settlement. Apart from low leakage in walls, ceilings, and floors, special attention was given to the sealing of plastic foils in windows and door mountings, in ways which would allow convenient conditions upon future replacements. As visible in Figure 57, a main consideration in the project was also to keep window and door areas unexaggerated, so as to maximize fully isolated outer wall areas in all settlement buildings.



Figure 57. Facades of the two multi-family passive houses at the Söndrums Kyrkby site (left), and one of eight two apartment ground pair houses (right). Source: [3].

The municipality of Halmstad is one of six municipalities within the Swedish administrative unit of Hallands län (SE231 in the NUTS3 region classification). In all, Hallands län covers a land area of 5720 km²[6] and hosts a total population of 301724 residents (December 31st, 2011 [7]), rendering a general population density of approximately 53 residents per square kilometre, see Figure 58. The municipality of Halmstad stretches over a land area of 1014 km²[8] and its population density is approximately 91 residents per square kilometre. In the city of Halmstad the total population reached 58577 residents on the 31st of December 2010, equalling a population density of 1716 residents per square kilometre, given a town land area of 34.13 km²[9].

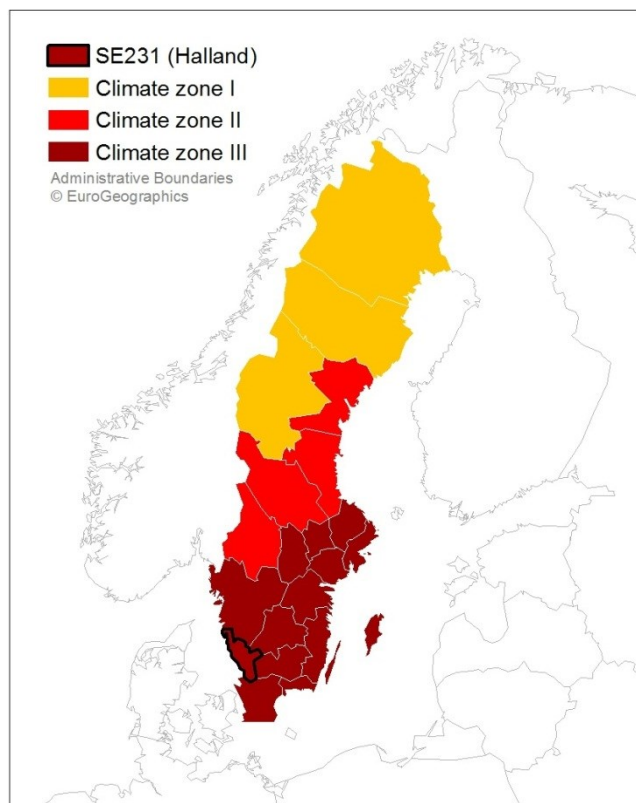

Figure 58. Swedish climate zones as defined in BBR 2012. NUTS3 region SE231 (Hallands län) marked by black perimeter. Source: [10].

Regulations for construction of new buildings in Sweden are assembled in a reoccurring publication from the Swedish housing agency (Boverket). In the latest version, the 2012 set of construction regulations (Regelsamling för byggande, BBR 2012 [10]), three climate zones are used to distinguish between northern, central, and southern regions of the country (Figure 58). As can be seen in

Table 5, general requirements with respect to specific energy use for new constructions¹¹ are allowed to increase with increasing latitude. In climate zone III, where the municipality of Halmstad is situated, the corresponding level of specific energy use is set to 90 kWh/m² heated area and year, for any new construction supplied with energy from non-electric alternatives. For electrical energy supply options, the levels are markedly reduced.

¹¹The sum of all bought energy for SH, DHW, and building electricity (BE) demands, not including household electricity (HE). Building electricity (BE) referring to electricity for e.g. circulation pumps, fans, common appliances and lighting.

Annex X Final Report: Toward 4th Generation District Heating

Table 10. Swedish standards of specific energy use for SH and DHW by three climate zones; BBR 2012 national regulations for new constructions and FEBY 2009 recommendations for Swedish passive houses

Climate zone	Zone I	Zone II	Zone III	Unit
BBR 2012 (Residential buildings)				
Spec. Energy use	130	110	90	kWh/m ² heated area, year
Spec. Energy use – electric heating	95	75	55	kWh/m ² heated area, year
FEBY 2009 (Residential and school buildings - recommendations)				
Spec. Energy use	58	54	50	kWh/m ² heated area, year
Spec. Energy use – electric heating	34	32	30	kWh/m ² heated area, year

As regards to the passive house concept, no formal regulations on specific energy use exist in Sweden today¹². But, recommendations have been assembled by the *Forum för Energieffektiva Byggnader* (FEBY, Forum for energy efficient buildings), which comprises an experienced work group with support from, among others, the Swedish Energy Agency. In the publication [11], corresponding levels of recommended specific energy use in passive houses are defined, as outlined in Table 10. From these it is evident that passive houses are expected to meet energy demands for SH, DHW, and building electricity (BE), by much lower supply levels compared to ordinary buildings. In the context of this case study, the term “low-energy” district heating implementation is hence deliberately chosen in the main heading, to distinguish between pure low-temperature district heating applications and conventional district heating technology in conjunction with low-energy buildings.

Technical description

The term “passive” in the passive house concept refers to the relatively enhanced dependency on internal heat contributions to meet total heat demands of a building. Internal heat contributions, originating in the use of e.g. electrical appliances, human activities, solar irradiation etc., constitute a relatively higher share of the total heat supply in passive houses compared to ordinary buildings, why thermal comfort in passive houses is more sensitive to resident behavior.

Two basic principles of passive houses are (i) massive insulation (low transmission losses) and (ii) high degree of air-tightness, both acting to minimize energy losses through the building envelope. One important consequence of these principles is that in-door surface temperatures remain close to room temperatures, why thermal comfort can be maintained without the use of traditional radiators [12]. Instead, the use of controlled air systems are

¹² In the energy design analysis performed for the Söndrums Kyrkby project [2], the 2008 version of the BBR regulations were used. In the 2008 version, newly constructed residential buildings in the southern climate zone of Sweden were prompted to be designed with specific energy use below 110 kWh/(m² heated area, year), including SH, DHW, and BE use. For passive houses in the same climate zone, the corresponding specific energy use was determined to 45 kWh/(m² heated area, year), although it remains uncertain whether this value was to be interpreted as a regulation or a recommendation.

Annex X Final Report: Toward 4th Generation District Heating

frequently seen in passive houses, which by additional exhaust air heat recovery contributes to further reducing the need of external heat supply. According to Swedish passive house recommendations, as expressed by FEBY [11], the use of controlled air systems with exhaust air heat recovery is in principle mandatory, although exceptions from this are accepted on the basis of geographical location.

In the case of Sweden, the two basic principles of passive houses are expressed quantitatively by a specified heat transfer coefficient demand for windows not exceeding $0.90 \text{ W}/(\text{m}^2\text{°C})$. From practice, a general average building envelope heat transfer coefficient of $0.1 \text{ W}/(\text{m}^2\text{°C})$ is common in Swedish passive houses. Compared to standard passive houses in central Europe, e.g. in Germany and Switzerland, where corresponding k-values often range from 0.11 to $0.25 \text{ W}/(\text{m}^2\text{°C})$ [12], the heat transfer coefficient values from the Swedish example indicate an adaptation to colder seasonal climate.

The two multi-family tower block passive houses are built on flat plates upon the ground and the outer walls are fitted with 310 - 340 mm of insulation, rendering average outer wall heat transfer coefficients of $0.14 \text{ W}/(\text{m}^2\text{°C})$. Since the multi-family buildings comprises relatively less outer wall areas for each apartment compared to the ground pair houses, the insulation thickness were designed not to match those used in these. In the ground pair houses, a slightly thicker outer wall insulation thickness of 400 mm is used, rendering average heat transfer coefficients of $0.09 \text{ W}/(\text{m}^2\text{°C})$. In both multi-family buildings and in all pair houses, ground floor insulation thickness of 300 mm is used ($0.10 \text{ W}/(\text{m}^2\text{°C})$ and $0.08 \text{ W}/(\text{m}^2\text{°C})$, respectively), as well as 500 mm insulation thickness in building roofs ($0.07 \text{ W}/(\text{m}^2\text{°C})$ and $0.085 \text{ W}/(\text{m}^2\text{°C})$, respectively).

Regarding building envelope tightness, the FEBY specifications indicate maximum air leakages at +/- 50 Pa pressure difference to no more than $0.30 \text{ dm}^3/(\text{sm}^2)$. Initial testing of the two multi-family buildings at the Söndrums Kyrkby settlement, where the complete building envelope was measured, recorded average air leakages of $0.19 \text{ dm}^3/(\text{sm}^2)$ [4]. Outer wall areas designated for the use of windows correspond to 20-22% of heated area in the multi-family buildings, to 18.5% of heated area in pair house (B), and to 16.5 % of heated area in pair house (C).

As described above, the apartments in the multi-family houses range from two rooms to four rooms, and in the pair-houses; combinations of a two-room and a four-room apartment, or two three-room apartments. In Figure 59 and Figure 60, schematic overviews of plan configurations in both multi-family buildings and pair houses are presented.

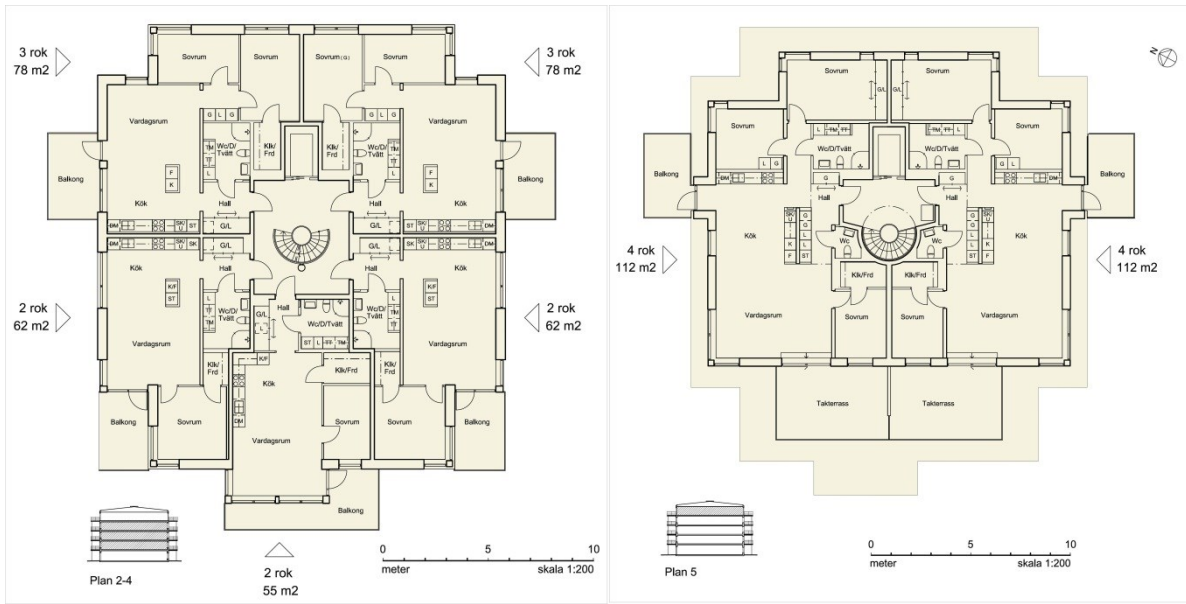

Figure 59. Schematic overview of apartments in multi-family passive houses (A), floors 2 to 4 (left), and floor 5 (right). Source: [3].

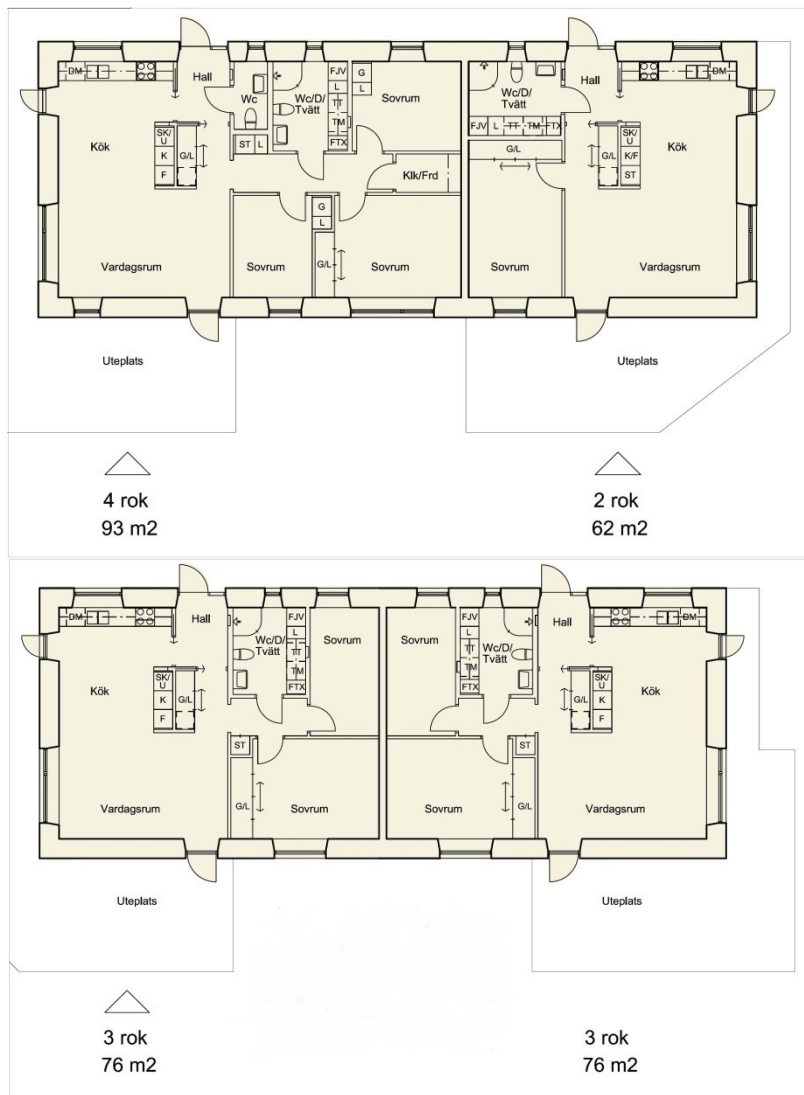

Figure 60. Schematic overview of apartments in pair passive houses B (above), and apartments in pair passive houses C (below). Source: [3].

An interesting experience from the Söndrums Kyrkby project is – in contrast to often heard conceptions of passive house technology – that it is not reaching recommended apartment indoor temperatures in wintertime that presents the hardest challenges: it is rather to avoid over-temperatures in summertime that constitutes the largest difficulties [4]. Highly insulated and air-tight constructions are equally capable of reducing transmission flows from the inside and out (a typical winter situation), as well as from the outside ambience to the inside (typical summer situation). As the passive house building slowly heats up during long, hot summer days, the low heat conductivity properties of the building envelope prevents effective night cooling, why measures to prevent over-heating was considered in the project.

One measure taken was to install windows with solar protective glass in all façade windows. According to the energy design analysis [2], windows in the two multi-family buildings were thus to meet demands on solar energy transmittance corresponding to 35-40%, and in the ground pair houses corresponding to 35%. Alternative solutions to this problem could also be adjustable wall shields to screen out incoming sun light.

Heat demand

A critical issue often noted in relation to passive houses and district heating is the potential conflict of high investment costs for network heat supply, and the relatively low heat demands of passive houses. Expansions of district heating systems are dependent on heat distributors being able to achieve feasibility on the basis of heat sales, which might be hazardous in areas with low-energy housing [13]. Well aware of this circumstance, the project task group decided early on to integrate the two multi-family tower block buildings among the eight ground pair houses to increase the linear heat density of the settlement site. As already mentioned above, the project initiators, HFAB, were also keen to establish a thorough agreement with the local district heat supplier, HEM, at an early stage of the project.

This agreement, according to personal communication with the project coordinator at HFAB [14], came to resemble a mutual benefit for both parties. As for HFAB and the Söndrums Kyrkby passive house settlement, additional costs for site distribution heat losses could be avoided by arranging for the district heat to be supplied directly to each building (see further Figure 64 and Figure 65 below). Additionally, HFAB commissioned the district heat supplier to recommend and deliver suitable plate heat exchangers to be used in all the ground pair houses¹³, a purchase thus streamlined for its purpose. As for HEM, the city municipal energy company distributing the district heat, the agreement and site configuration provided evidence (for public relations) that district heating very well may be a viable alternative in passive house residential areas. As more housing areas are expected to have reduced heat demands for SH in the future, the commercial value of such an experience is of natural importance for the

¹³In the multi-family buildings, HFAB were themselves responsible for the choice and purchase of heat exchangers. As customary in Sweden, the responsibility of the district heat supplier was in this case to provide the service pipe to and within the building wall.

Annex X Final Report: Toward 4th Generation District Heating

company. Economic conditions, e.g. specific distribution capital costs, for the current district heat supply to the settlement site have not been possible to investigate at this stage.

At the Söndrums Kyrkby passive house settlement, the most reliable information on average annual energy use at current date is the calculated values presented in the initially performed energy design analysis [2]. According to this document, the calculated annual average energy use for SH in the multi-family building apartments are 11 kWh/m² (referring to indoor temperature levels of 20 °C). Annual average heat demands for DHW are calculated to 29 kWh/m², and an additional annual average of 5 kWh/m² calculated for BE, thus totaling at 45 kWh/m². At this indoor temperature, the corresponding specific power was further estimated to 10 W/m². For four-room apartments in ground pair-house (B), corresponding calculated annual average energy use for SH was 9 kWh/m², for DHW; 28 kWh/m², and for BE; 4 kWh/m², totaling at 41 kWh/m², see further Table 6.

Table 11. Heat loads and energy demands for SH, DHW, and BE, at the Söndrum Kyrkby multi-family and pair passive house settlement in Halmstad. Measurements refer to year 2011. Sources: [15] and [2]

Heat loads and energy demands	Value	Unit
Peak power SH & DHW - per building (A) ¹	20	kW
Peak power SH & DHW - per apartment (B) – 4 rooms ¹	2	kW
Peak power SH & DHW - per apartment (B) – 2 rooms ¹	1	kW
Peak power SH & DHW - per apartment (C) – 3 rooms ¹	1	kW
Peak power SH & DHW - all buildings	59	kW
Total heat demand SH & DHW - per building (A) ¹	70260 (measured)	kWh/year
Total heat demand SH & DHW - per building (A) ¹	253 (measured)	GJ/year
Total heat demand SH & DHW - per building (B) ¹	8316 (measured)	kWh/year
Total heat demand SH & DHW - per building (B) ¹	30 (measured)	GJ/year
Total heat demand SH & DHW - per building (C) ¹	11848 (measured)	kWh/year
Total heat demand SH & DHW - per building (C) ¹	43 (measured)	GJ/year
Total heat demand SH & DHW - all buildings ²	224708 (estimated)	kWh/year
Total heat demand SH & DHW - all buildings ²	809 (estimated)	GJ/year
Specific heat loads and energy demands	Value	Unit
Spec. SH demand (DH) – per building (A) ³	11 (calculated)	kWh/m ² heated area, year
Spec. DHW demand (DH) – per building (A) ³	29 (calculated)	kWh/m ² heated area, year
Spec. BE demand (EI) – per building (A) ³	5 (calculated)	kWh/m ² heated area, year
Total SH, DHW & BE demand – per building (A) ³	45 (calculated)	kWh/m ² heated area, year
Spec. SH demand (DH) – per apartment (B) – 4 rooms ³	9 (calculated)	kWh/m ² heated area, year
Spec. DHW demand (DH) – per apartment (B) – 4 rooms ³	28 (calculated)	kWh/m ² heated area, year
Spec. BE demand (EI) – per apartment (B) – 4 rooms ³	4 (calculated)	kWh/m ² heated area, year
SH, DHW & BE demand – per apartment (B) – 4 rooms ³	41 (calculated)	kWh/m ² heated area, year
Spec. SH demand (DH) – per apartment (B) – 2 rooms ³	12 (calculated)	kWh/m ² heated area, year
Spec. DHW demand (DH) – per apartment (B) – 2 rooms ³	21 (calculated)	kWh/m ² heated area, year
Spec. BE demand (EI) – per apartment (B) – 2 rooms ³	5 (calculated)	kWh/m ² heated area, year
SH, DHW & BE demand – per apartment (B) – 2 rooms ³	38 (calculated)	kWh/m ² heated area, year
Spec. SH demand (DH) – per building (C) – 3 rooms ³	11 (calculated)	kWh/m ² heated area, year
Spec. DHW demand (DH) – per building (C) – 3 rooms ³	23 (calculated)	kWh/m ² heated area, year
Spec. BE demand (EI) – per building (C) – 3 rooms ³	4 (calculated)	kWh/m ² heated area, year
SH, DHW & BE demand – per building (C) – 3 rooms ³	38 (calculated)	kWh/m ² heated area, year

¹ Annual measurement in one of each characteristic building/apartment according to [15].

² Assessment based on measurements, not including optional extra individual electrical heating of inlet air.

³ Calculated average annual values according to [2].

Annex X Final Report: Toward 4th Generation District Heating

Since data covering a full year of operation for the entire settlement yet is not available, the scarce and incomplete accounts that have been made available from the district heat distributor serves in this context as indications only. Still, according to these schematic data, which are detailed for one multi-family building (A), for one ground pair house (B), and for one ground pair house (C) [15], the measured levels of energy use and heat loads at the site during 2011 are as presented in Table 6. District heating provides the base load for SH and DHW, although additional SH is opted for by individual use of electrical heating of the ventilation inlet air. Apartments are leased to tenants with (district heat) space heating included in the monthly charge, while use of additional heat supply by means of electrical heaters are charged individually on the electricity bill.

Further, monthly rental charges are designed to reflect individual use of DHW, which is made possible by volume metering of DHW flows in each apartment, see also **Fejl! Henvisningskilde ikke fundet.** below. A “normal” volume of DHW is included in the monthly rental charge, but excesses are charged extra analogously as sparse use of hot water is honored by corresponding cost reductions of the monthly fare.

Building installations

In each of the two multi-family passive houses at the Söndrums Kyrkby settlement, a ground floor technique room houses the forced air ventilation systems, the district heating sub-stations, heat exchangers for DHW, and additional equipment. District heat for SH is supplied to the inlet air as it passes through the air inlet channel after pre-heating through heat recovery from the exhaust air – a process which is performed by a centrally placed rotating heat exchanger operating at an average recovery efficiency of 85-90%, see Figure 61. The heat load for SH in each multi-family building apartment is thus met firstly by recovery of heat in the exhaust air, secondly by additional district heat to reach the required apartment indoor temperature of 20 °C (see also **Fejl! Henvisningskilde ikke fundet.** (left)), and – as a third option – by additional individual use of electrical heating of the inlet air in each apartment to reach higher indoor temperatures.



Figure 61. Forced air ventilation system with centrally placed rotating heat exchanger and subsequent district heat added as base load heat supply. Photo: The Author.

Regarding exhaust air heat recovery by means of a centrally placed rotating heat exchanger, the experiences from the project task group indicate that maintained high recovery efficiency in this vital component is crucial for continued operation within passive house requirement levels regarding specific energy use [4]. As any project designer is interested in locating and installing as cost-efficient and price-worthy equipment as possible, this unit – the rotating heat exchanger – is advisably not the component to be stingy about. Another related issue concerning the use of rotating heat exchangers, also experienced at the Söndrums Kyrkby settlement, is the risk of odour recovery as well as heat recovery during operation. To counteract this risk, a centrally placed carbon filter is installed in the inlet air channel, as well as individual carbon filters above stoves in each apartment kitchen [14]. By these measures, no major problems with contaminated inlet air have occurred in the project.

By a separate plate heat exchanger unit also placed in the ground floor technique room, DHW is prepared by district heat supply and individually distributed to each apartment, see **Fejl! Henvisningskilde ikke fundet.** (right). Typical for passive houses, the annual heat load for DHW comprises a relatively more dominant share of the total yearly heat load, compared to regular buildings, why it is especially important to also have DHW prepared by district heat when district heating is connected to passive house settlements. If an electrical alternative were to be chosen instead, it is likely that the remaining heat load (SH only) wouldn't be sufficient enough to provide feasible network heat distribution conditions. Analogously, heat peak loads in passive houses often occur during night hours, due to high dependency on internal heat gains not present during such hours, which liberates (by time shifting) district heat generation from part of the regularly high morning load. Visible in **Fejl! Henvisningskilde ikke fundet.** (right) are also the expansion unit for the DHW circuit, two motor driven valves and some gauging equipment.

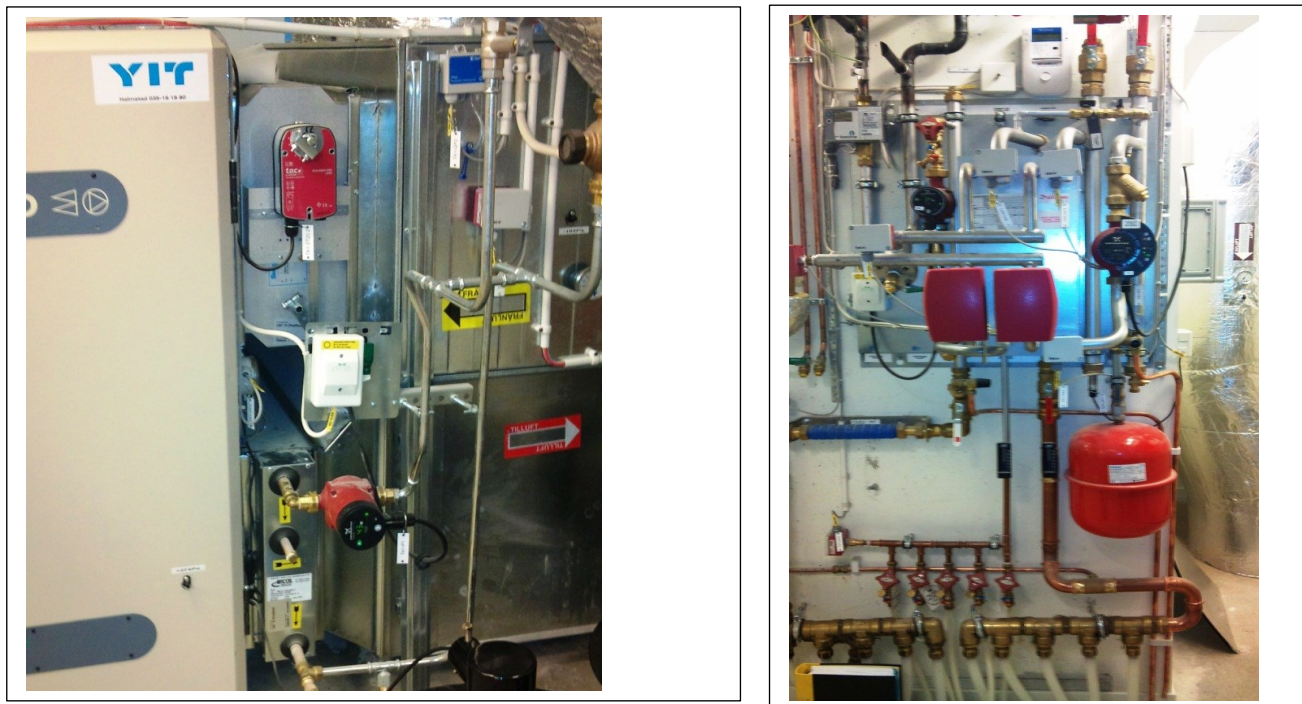

Figure 62. Close up of district heat supply heat exchanger in central air ventilation system (left), and district heat supply heat exchanger for DHW (right). Photos: The Author.

In the ground pair houses, in which each apartment is individually connected to the district heat supply by standard counter current heat exchangers placed in apartment WC's, the heat load is also satisfied partly by exhaust air heat recovery and district heat supply. The district heat load for SH and DHW is, according to [16], dimensioned to deliver approximately 1500 kWh for SH and 4000 kWh for DHW annually per ground pair houses apartment. In all buildings at the Söndrums Kyrkby settlement, equipment to facilitate individual measurement of DHW use in each apartment has been installed, as presented in **Fejl! Henvisningskilde ikke fundet.** As mentioned above, the use of DHW is reflected in the monthly rental charge and gauging thus stimulates efficient resident use of DHW.



Figure 63. Installed equipment to facilitate individual metering of DHW use in each apartment. Photo: The Author.

Measurement data of DHW use, as well as of district heat delivery volumes, district heat supply and return temperatures, are gathered and stored by the district heat supplier HEM through an internet interface. Regretfully, no satisfactory admission to these data has been possible during the work with this case study. For this reason, data on district heat supply and return temperature levels given in Table 12 below, which are based on temperature data for a limited time sequence (January 1st to mid-June, 2012) given by HEM [16], are anticipated average values based on extrapolations of given information.

Heat distribution network

The Söndrums Kyrkby settlement site is connected to the heat distribution network of the city of Halmstad by a short (100 meters) twin DN50 standard pipe (1) stretching from the main distribution pipe line (2) to the site location (3), see Figure 64. The main distribution network is dimensioned for a maximum pressure of 16 bar(a), but operating pressures are approximated to 10 bar(a) in the supply pipe and to 8 bar(a) in the return pipe. As the main distribution network provides heat supply for industrial customers downstream of the Söndrums Kyrkby settlement site, supply temperatures are stated to never be below 90 °C, except during summer months (≈ 70 °C), according to [16]. From the scarce data available on site district heat supply and return temperatures, mentioned above and detailed in Table 12 below, the question arises whether some cooling (mixing with cool return flow) of the site district heat supply is performed since recorded temperatures are lower than the above stated. This eventuality remains to be investigated.

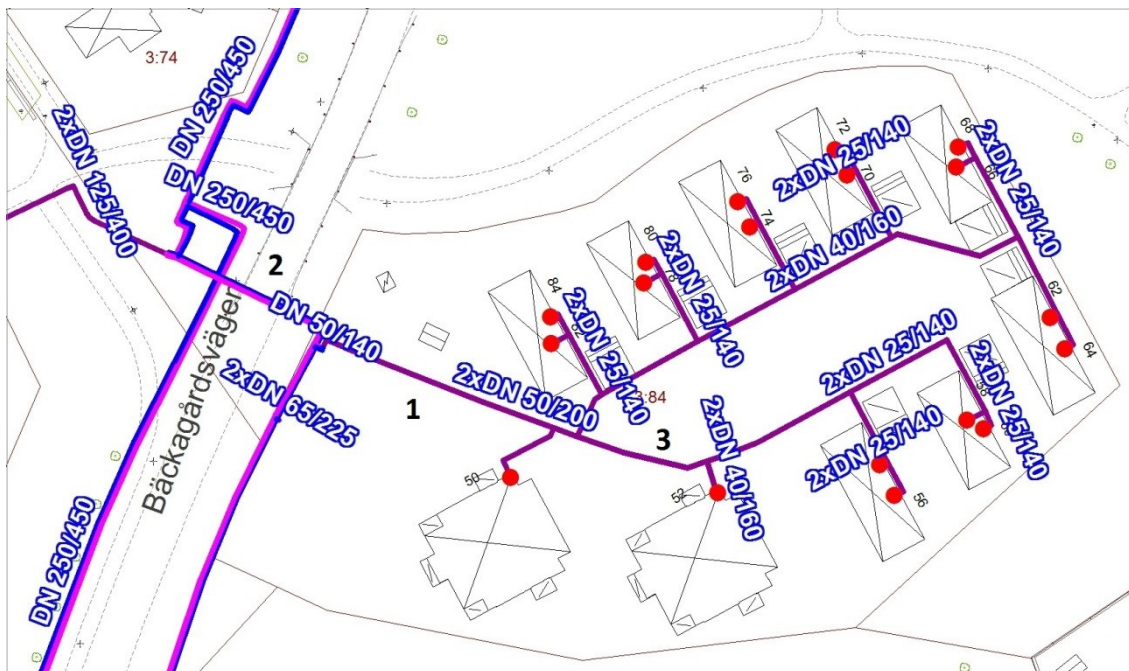

Figure 64. Overview of the heat distribution pipe line from the district heating network of the city of Halmstad and the connection pipe to the Söndrum Kyrkby settlement site. Source: [17].

At the ground site, the district heat supply is sub-distributed to 18 separate connection points, one at each multi-family building and two at each ground pair house (see red dots in Figure 64 and Figure 65), by use of DN40 scaled service pipes to the two multi-family buildings and DN25 service pipes to the ground pair houses. Heat deliveries to the 18 connection points are charged to HFAB by HEM, and HFAB subsequently charges the settlement residents for heat use as an integrated part of the monthly rental charge.

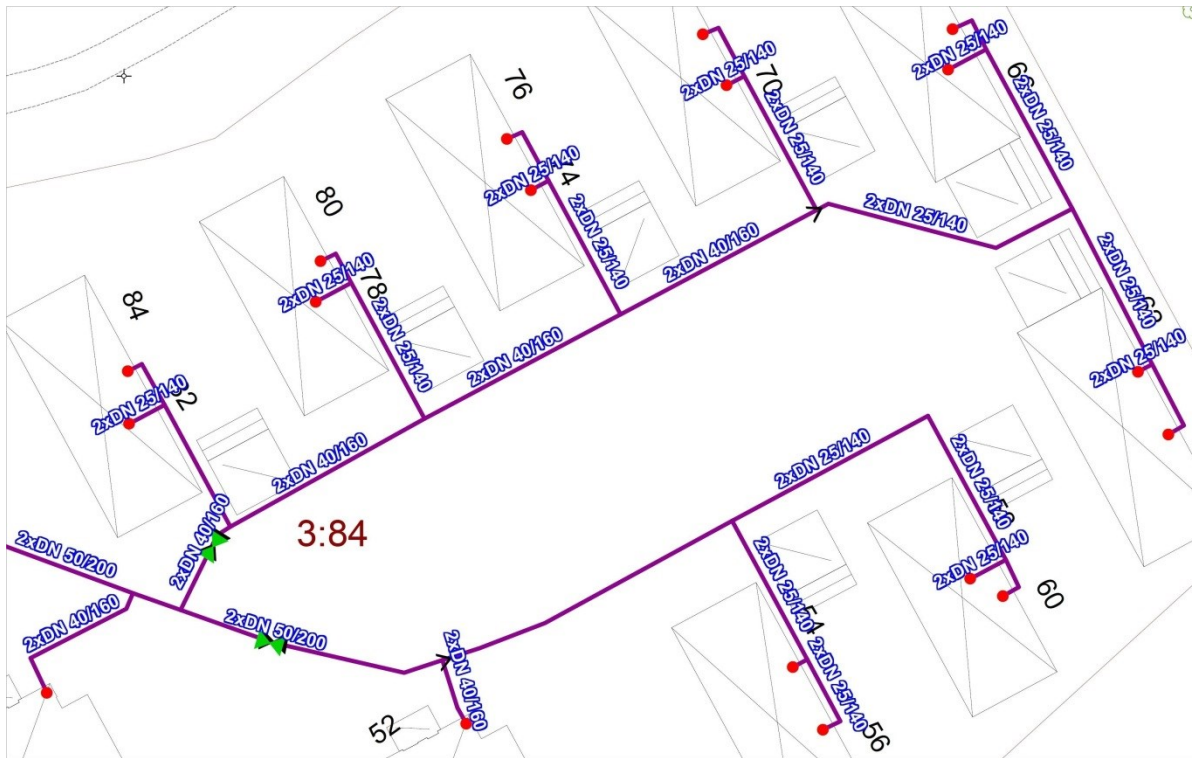

Figure 65. Configuration and dimensions of the Söndrums Kyrkby site heat distribution network. Source: [15].

The first district heat deliveries in the city of Halmstad began already in 1980, at this time operated by the city municipality as part of the common service. In 2006, as many previous municipal activities in Sweden were converted to commercial enterprises during the latter part of the 1990's and in the early 21st century, the energy company Halmstad Energi och Miljö AB (HEM) – owned at 100% by the city municipality – began operating the district heat distribution in the city and supplied in 2011 approximately 45000 city residents with energy and environmental services (district heat, electricity and MSW management) [18].

The energy company HEM relies mainly on incineration on municipal solid waste (MSW) and biomass for the fuel mix in the district heat supply, with some additional industrial excess heat recovery from a locally placed Pilkington glass mill. According to [19], a total of 652 GWh was supplied into the district heating network of Halmstad in 2008, a supply which consisted of 85% municipal and industrial solid wastes, 10% biomass mainly in the form of wood residues, 4% natural gas, and 1% crude oil. At this high share of non-fossil fuel sources – although some minor fossil shares are present in the form of plastics in the used waste streams – the district heat in the city of Halmstad provides city residents with a truly low carbon footprint heat supply.

Annex X Final Report: Toward 4th Generation District Heating

By deciding to use the city district heating network for base load heat supplies at the Söndrums Kyrkby site, although challenged by the relatively low linear heat densities there, the project task group ensured that the multi-family and pair passive house settlement could enjoy both energy efficient housing and environmentally sound heating. This case study hence serves as an example on a successful combination of these two parameters, and especially to point out that district heating very well may operate in conjunction with low energy housing.

In the context of the IEA-DHC/CHP Annex X project; Towards 4th Generation District Heating, the work programme is divided into two phases. The first phase aims at assembling a folder of case studies, such as this one, with national examples of low-temperature and low-energy district heating implementations. In the second phase, which is scheduled for the latter part of 2012 and the spring of 2013, the assembled case studies of the first phase will provide information for analysis in search of general and common features characteristic for 4th generation applications. One such feature is the specific investment cost for district heating networks, the distribution capital cost [20]. To provide relevant in-data parameters for such – and other – calculations, it has been proposed during the research process for all case studies to provide information according to the data categories (Quantity) presented in Table 7. In this table, corresponding values for the Söndrums Kyrkby multi-family and pair house passive house settlement in Halmstad are presented.

Table 12. District heating input data parameters at Söndrums Kyrkby multi-family and pair passive houses in Halmstad. Source: [2], [16], and own estimations as indicated

Quantity	Label	Value	Unit
Trench length	L	470	m
Annually sold heat - total	Q _S	809	GJ/year
Annually sold heat - total	Q _S	225	MWh/year
Linear heat density	Q _S /L	1.7	GJ/m,year
Linear heat density	Q _S /L	0.48	MWh/m,year
Average pipe diameter ¹	d _a	0.038	m
Thermal conductivity of pipe insulation ²	k	0.026	W/(m°C)
Average supply temperature	T _S	70 (anticipated) ⁵	°C
Average return temperature	T _R	38 (anticipated) ⁵	°C
Average ambient temperature	T _A	8	°C
Average supply temperature(heating season) ³	T _{S,hs}	76 (anticipated) ⁵	°C
Average return temperature(heating season)	T _{R,hs}	40 (anticipated) ⁵	°C
Average ambient temperature(heating season)	T _{A,hs}	4	°C
Average supply temperature(non-heating season) ⁴	T _{S,nhs}	60 (anticipated) ⁵	°C
Average return temperature(non-heating season)	T _{R,nhs}	34 (anticipated) ⁵	°C
Average ambient temperature(non-heating season)	T _{A,nhs}	15	°C

¹Weighted arithmetic mean value of site supply and service pipelines.

²No data. Value refers to average thermal conductivity of standard pipe insulation.

³ 1st November – 30th April (Denmark, Sweden).

⁴ 1st May – 31st October (Denmark, Sweden).

⁵ Anticipated average values extrapolated from limited temperature data (January to June, 2012) given in [16].

Planning principles and implementation strategies

Applied urban planning policies/instruments

The multi-family and pair passive house project at Söndrums Kyrkby was on an initial stage set to fulfill clearly defined targets and ambitions. The targets were synonymous to those applied

Annex X Final Report: Toward 4th Generation District Heating

for Swedish passive house standards of the time regarding specific energy use, heat transfer coefficients of building envelopes, windows etc. The ambitions of the project work group were concentrated in three specific project documents. In short, these documents addressed:

- Energy design analysis – a thorough evaluation of the energy performance of the planned settlement, performed by an external consultant at project start-up
- How to avoid moisture in building materials during construction phase – a consensus document to unite actions of project coordinators, sub-contractors, HVAC installers, and other personal during settlement construction
- Detailed specification document on how to achieve high building envelope tightness, with instructions to project sub-contractors and installers.

It is likely that the development of these documents supported the coordination of the project and helped establish a high level of mutual understanding among project partners regarding the critical issues addressed. Further, the choice of district heating for site heat supplies, although alternatives such as solar thermal panels and heat pumps were considered, proved to be beneficial – especially by the reaching of an early agreement regarding the design of the heat supply with the local district heat operator. The project was completed according to the construction time table, and entered into operation during the summer of 2010, see Figure 66.



Figure 66. The Söndrums Kyrkby multi-family and pair passive house settlement in operation. Source: [14].

Tools used for energy monitoring

All heat energy supply and use at the Söndrums Kyrkby multi-family and pair passive houses are recorded by the HEM monitoring system, although this data was not in full made available during the writing of this case study. The data from energy monitoring is continuously made available to the settlement owners, HFAB, which uses some of this data to correctly size monthly rental charges for site residents (individual DHW use being reflected in these), and to perform continuous evaluations of the operation of building installations.

SWOT Analysis

	Helpful to achieving the objective	Harmful to achieving the objective
Internal origin	<p><i>Strength</i></p> <ul style="list-style-type: none"> - Good planning; three project documents produced at project start-up detailing expected levels of project partner discipline and targeted energy design etc. - At choosing district heat for base heat load supplies: recognition of need for increased linear heat density of site. Inclusion of two multi-family buildings in site plan. - Individual metering of DHW use – measure to stimulate efficient resident water use. 	<p><i>Weakness</i></p> <ul style="list-style-type: none"> - Choice of using electrical heating as optional additional heat supply in individual apartments.
External origin	<p><i>Opportunities</i></p> <ul style="list-style-type: none"> - Early agreement with DH supplier – mutual benefit achieved. - Cooperation with other external parties, e.g. offering research opportunities for local universities. 	<p><i>Threats</i></p> <ul style="list-style-type: none"> - In passive houses; more hazardous to prevent indoor over-temperatures during non-heating season than securing required indoor temperatures during heating season. Early planning need to recognize this and include solar shading equipment etc.

Conclusions and lessons learnt

From the perspective of energy efficiency and the key property of district heating systems to recover and distribute excess heat that would otherwise be wasted [21], district heat represents a strategic and environmentally beneficial solution, in comparison to fossil fuels and electricity being directly used to satisfy low temperature residential and service sector heat demands. As such, passive houses – and especially multi-family passive houses – could ideally add value to the operation of future district heating systems, by acting as temporal thermal heat storages to level out shorter periods of peak heat demands, and also by time dispersion of peak heat demands. In a development with larger proportions of low-energy houses with high thermal inertia connected to traditional district heating systems, reduced demand for investments in peak generation facilities could improve the economy of 3rd generation network heat distribution. By the reduced supply and return temperatures associated with the 4th generation of district heating – and the subsequent possibility to use alternative and less costly pipe materials – these features of low-energy buildings are likely to gain in importance.

Annex X Final Report: Toward 4th Generation District Heating

The Söndrums Kyrkby settlement provides evidence for the viability of combining extremely energy lean housing and district heating as base load heat supply. Although significantly reduced SH demands inflict equally reduced linear heat densities at passive house settlements, district heating – here relatively more dependent on demands for DHW – constitute a beneficial heat supply options as long as heat generation is performed with high shares of non-fossil fuel sources and network heat distribution can be achieved under acceptable economic conditions. In this respect, an important experience from this case study is found in the proactive engagement of the project owners, as they early on managed to establish a mutually beneficial agreement with the district heat operator regarding the design, installation, connection, and operation of the district heat supply at the project site.

References

- [1] HFAB, “Årsredovisning 2011 (Annual financial report 2011),” Halmstads Fastighets AB, Halmstad, 2012.
- [2] K. Adalberth, “HFAB, Söndrums Kyrkby, Nybyggda bostäder Söndrum 3:8, Halmstad Kommun, 11.9 Beskrivning Energidesign Utförande entreprenad (HFAB, Söndrums Kyrkby, Newly Built Dwellings Söndrum 3:8, Halmstad Kommun, 11.9 Description Energy design Execution Contract),” Prime Project AB, Lund, 2009.
- [3] HFAB, “Söndrums Kyrkby Bofaktabroschyr (Söndrums Kyrkby Fact Brochure),” Halmstads Fastighets AB, Halmstad, 2009.
- [4] HFAB, *Personal communication with Ulf Johansson 2012-08-15*, Halmstads Fastighets AB, Halmstad, 2012.
- [5] Boverket, “Regelsamling för byggande, BBR 2008 (Regulations for construction, BBR 2008),” Boverket, Karlskrona, 2007.
- [6] Eurostat, “Area of the regions [demo_r_d3area],” [Online]. Available: <http://epp.eurostat.ec.europa.eu/portal/page/portal/eurostat/home>. [Accessed 01 03 2012].
- [7] Statistics Sweden, “Folkmängd i riket, län och kommuner 31 december 2011 och befolkningsförändringar 1 oktober - 31 december 2011 (population statistics),” [Online]. Available: http://www.scb.se/Pages/TableAndChart____228185.aspx. [Accessed 11 06 2012].
- [8] Statistics Sweden, “Kommunarealer den 1 januari 2012 (km²),” Statistiska Centralbyrån, Stockholm, 2012.
- [9] Statistics Sweden, “Tätorternas landareal, folkmängd och invånare per km² 2005 och 2010,” Statistiska Centralbyrån, Stockholm, 2012.

Annex X Final Report: Toward 4th Generation District Heating

- [10] Boverket, "Regelsamling för byggande, BBR 2012 (Regulations for construction, BBR 2012)," Boverket, Karlskrona, 2011.
- [11] FEBY, "Kravspecifikation för Passivhus (Demand specification for passive houses)," Forum för Energieffektiva Byggnader/IVL Svenska Miljöinstitutet AB, Göteborg, 2009.
- [12] D. Nilsson, "Fjärrvärmeanslutna passivhus: Fallstudie av värmelaster och innetemperaturer i fyra flerbostadshus," Halmstad University, Halmstad, 2012.
- [13] S. Lembke, "Passivhus i ett svenskt klimat - en byggnadsfysikalisk riskinventering och erfarenhetssammanställning av befintliga passivhusprojekt," Examination thesis, Institutionen för bygg- och miljöteknik, Chalmers Tekniska Högskola, Göteborg, 2008.
- [14] HFAB, *Personal communication with Ulf Johansson 2012-04-20*, Halmstads Fastighets AB, Halmstad, 2012.
- [15] HEM, *Personal communication with Birgitta Andersson 2012-02-14*, Halmstad Energi och Miljö AB, Halmstad, 2012.
- [16] HEM, *Personal communication with Thore Carlsson 2012-06-21*, Halmstad Energi och Miljö AB, 2012.
- [17] HEM, *Personal communication with Birgitta Andersson 2012-06-26*, Halmstad Energi och Miljö AB, Halmstad, 2012.
- [18] HEM, "Vår verksamhet 2011, Halmstad Energi och Miljö AB," [Online]. Available: http://www.hem.se/extra/pod/?id=979&module_instance=1&action=pod_show. [Accessed 22 08 2012].
- [19] Länsstyrelsen i Hallands Län, "Energiläget i Halland 2010, Meddelande 2010:20 (Energy situation in Halland 2010, Message 2010:20)," Länsstyrelsen i Hallands Län, Halmstad, 2011.
- [20] U. Persson and S. Werner, "Heat distribution and the future competitiveness of district heating," *Applied Energy*, vol. 88, pp. 568-576, 2011.
- [21] U. Persson and S. Werner, "District heating in sequential energy supply," *Applied Energy*, vol. 95, pp. 123-131, 2012.

Appendix 4. Solar District Heating Network Munich Ackermannbogen - SNAB

General description

Project background and objectives

General information	
Country	Germany
City	Munich
Heating degree days ¹	4046
Specific information	
Project initiator /leader	Landeshauptstadt Muenchen
Year of construction/energy renovation	2006
Site area [ha]	2,3
Building units (residential)	320
Number of residents	
Building units (tertiary)	
Heated area [m ²]	28550
Plot ratio ²	1,3

¹ (base temperature: 20°C) ² built floor area/site area

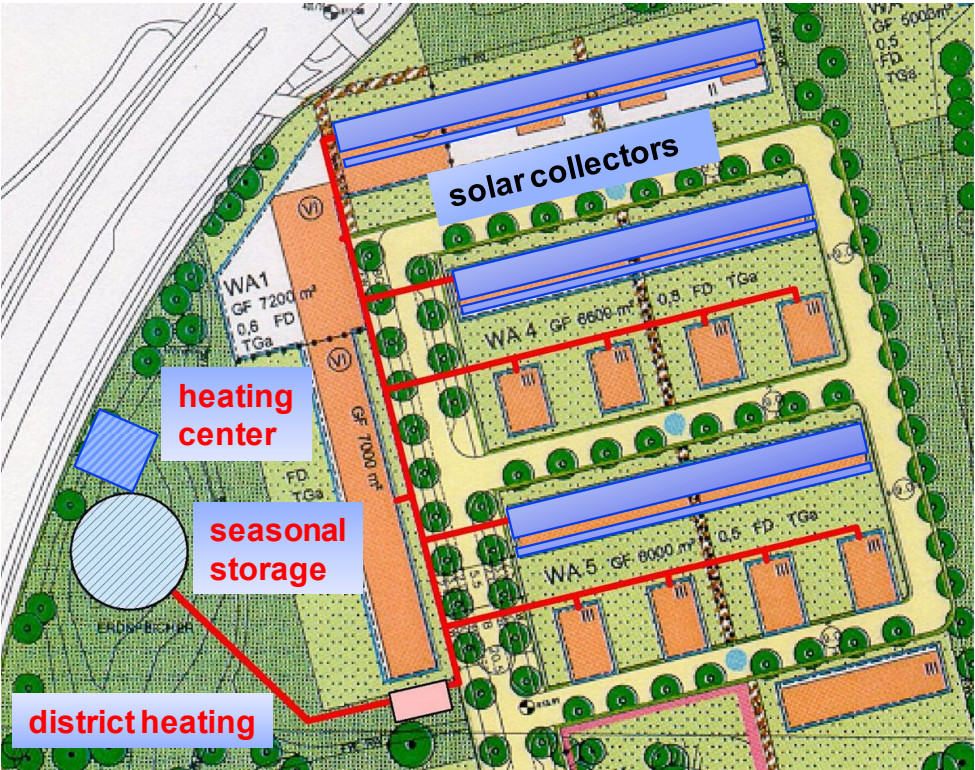

Annex X Final Report: Toward 4th Generation District Heating

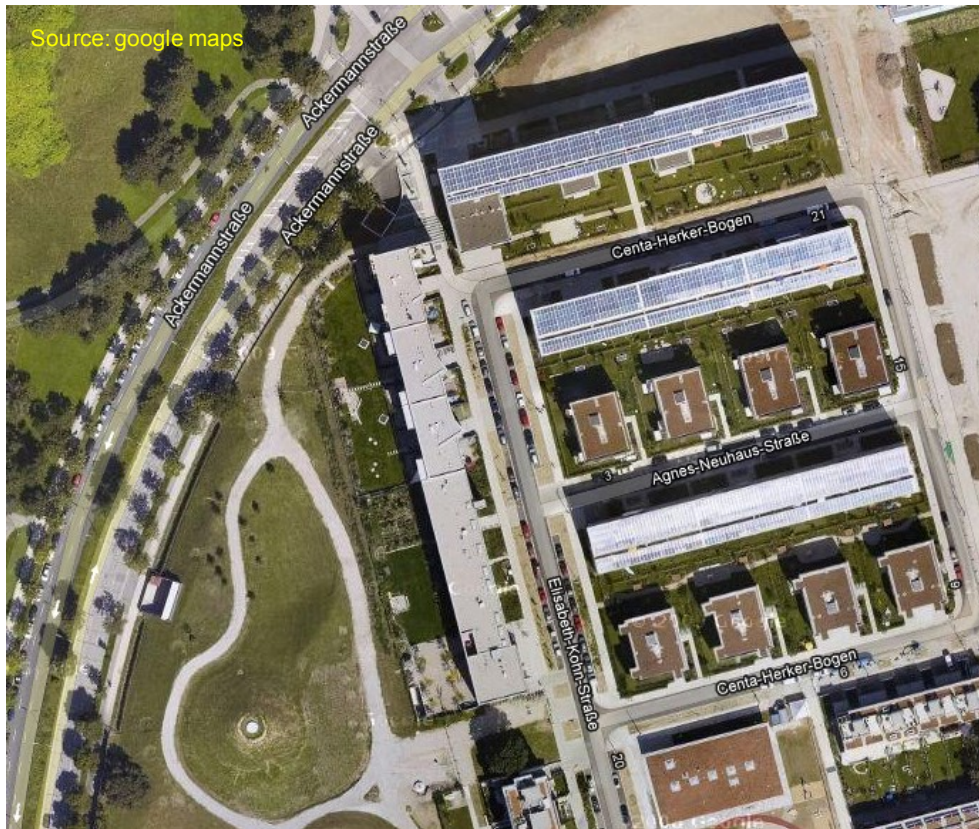



Technical description

Heat demand

Peak power [kW]	1534 kW (3 min average)
	450 kW (day average) (measured)
Total heat demand [GJ/yr]	6267 (measured)
Specific heat demand (residential)	
Specific space heating demand [$\text{kWh}_{\text{th}}/\text{m}^2$]	50 $\text{kWh}/\text{m}^2/\text{a}$ (design calculation)
Specific domestic hot water demand [$\text{kWh}_{\text{th}}/\text{m}^2$]	25 $\text{kWh}/\text{m}^2/\text{a}$ (design calculated)
Total [$\text{kWh}_{\text{th}}/\text{m}^2$]	62 $\text{kWh}/\text{m}^2/\text{a}$ (measured in 2008/2009)

Building installations

Direct flow through building

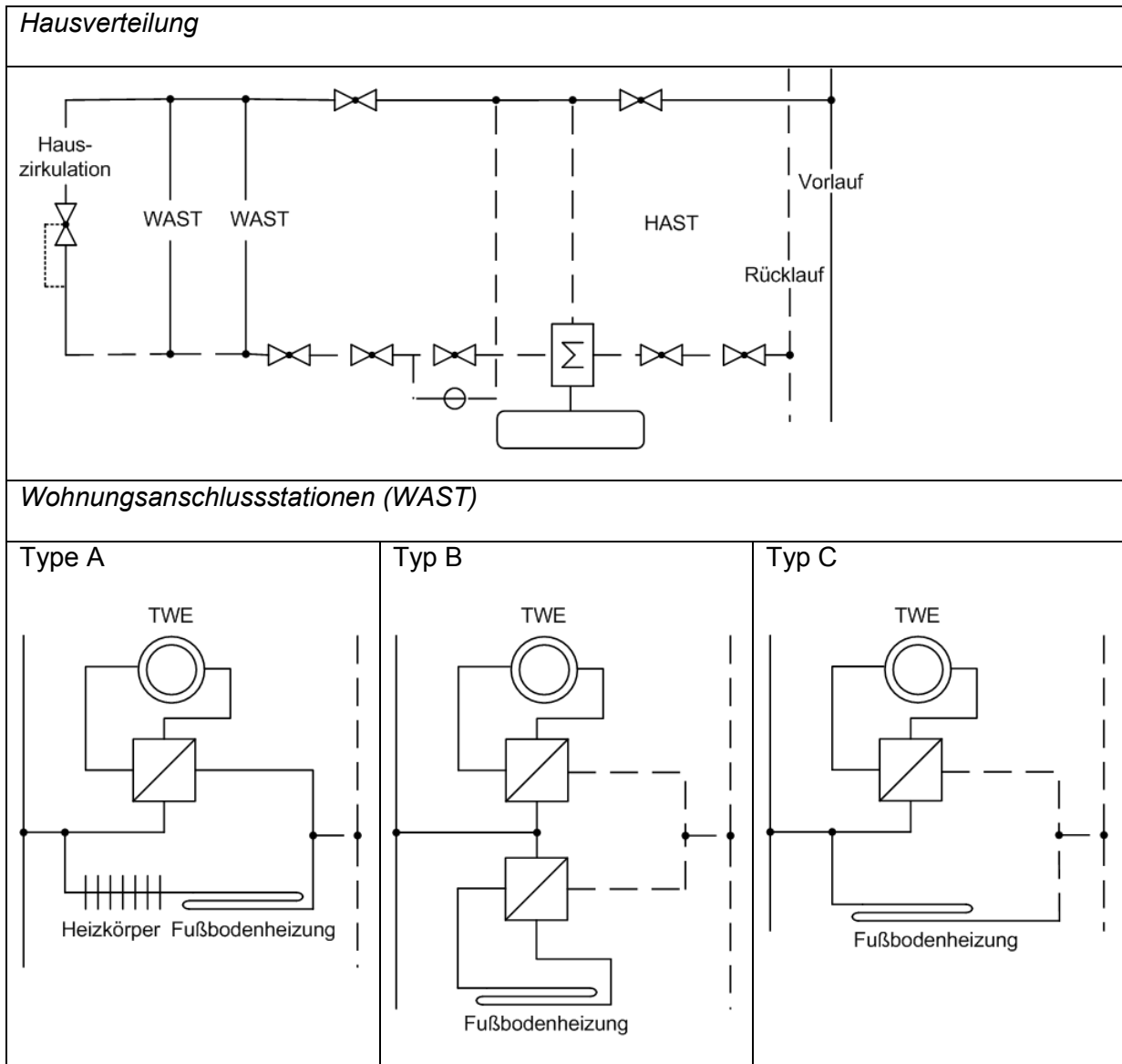

Space heating installations

Three types:

Direct flow radiator and floor heating

Direct floor heating

Indirect floor heating

Annex X Final Report: Toward 4th Generation District Heating

Domestic hot water installations

Flow Type heater

Domestic hot water distribution

No distribution, division at WAST

Heat distribution network

[...]

Trench length [m]	1240
Linear heat density [kWh/(m·yr)]	1430
Average T_{supply} [°C] (heating season) ¹	55
Average T_{return} [°C] (heating season) ²	30
Average T_{supply} [°C] (non-heating season)	55
Average T_{return} [°C] (non-heating season)	30

¹ In Denmark, 1st November – 30th April

² In Denmark, 1st May – 31st October

Heat sources

Solar Collectors (aperture 2761m², 18,5° average inclination, 14° SSE orientation)

Absorption Heat Pump (550 kW thermal power, 230 kW chilling power, COP 1.7, District heating driven)

Heat Storage 6000 m³ (85°C-15°C) (5700 m³ of water at 20 °C)

District Heating (Backup-System, 1650 kW)

Special R&D topics/issues

Analysis of all relevant energy flows.

Performance monitoring of the solar system and the absorption heat pump

Annex X Final Report: Toward 4th Generation District Heating

Analysis of the stratification unit in the water storage [...]

Additional energetic aspects

(Implemented measures reducing the heat demand, or targeting energy-efficiency heat generation and distribution, or RE exploitation; other...)

The insulation standard of the buildings realized was better than the by law required standard at the moment of building the houses. This results in an annual heating energy consumption reduced by 25 %.

Planning principles and implementation strategies

Applied urban planning policies/instruments

[...]

Applied energy models/tools

TRNSYS simulation of the whole system [...]

Tools used for energy monitoring

The system was equipped with temperature sensors and flow meters to register all relevant energy flows in the system. This allowed a detailed scientific analysis. [...]

Cost figures / Financial set-up / Incentives

[...]

SWOT Analysis

	Helpful to achieving the objective	Harmful to achieving the objective
--	---------------------------------------	---------------------------------------

Annex X Final Report: Toward 4th Generation District Heating

Internal origin	<p><i>Strength</i></p> <p>Scientific advisory team was involved from concept phase, in design and accompanied construction.</p> <p>Scientific monitoring and evaluation after commissioning.</p> <p>Several optimization measures could be realized</p>	<p><i>Weakness</i></p> <p>Project management team in the construction phase had a lack of experiences in the field of large solar installations and seasonal storage technology</p>
External origin	<p><i>Opportunities</i></p> <p>Funding program Solarthermie 2000plus</p>	<p><i>Threats</i></p> <p>Consultants and designers lack of experiences and thus hesitate to realize innovations</p>

Conclusions and lessons learnt

Very low return temperatures possible throughout the year (even at part load conditions) with this type of connection of flats and domestic hot water

Very low heat loss in network

Stratification units for large storage tank still require R&D

References

Kuckelkorn, Reuß, Schölkopf, Schweigler: Solare Nahwärme “Am Ackermannbogen” in München, EuroHeat&Power, 2008, Heft 4, Seiten 62-67

W. Dallmayer, J. Kuckelkorn, M. Radspieler, M. Reuß (project leader), W. Schölkopf, C. Schweigler, L. Staudacher: „Begleitforschung Solare Nahwärme Am Ackermannbogen – Endbericht“, ZAE Bayern, Garching, 2010

Robbi, Haas, Wirths, Eckstädt: „Multilevel District Heating – Teilthema II Multifunktionale Fernwärmesysteme – Endbericht“, TU Dresden, 2010

Appendix 5. Solar District Heating in the Drake Landing Community, Okotoks, Alberta, Canada

General description

Project background and objectives

The Drake Landing Solar Community in Okotoks, Alberta, Canada utilizes a solar thermal system with a Stratified Short Term Thermal Storage (STTS) and a seasonal thermal storage (Borehole Thermal Energy Storage, BTES) to supply space heating to 52 energy-efficient, detached houses through a low-temperature district heating network. The system was designed to supply at regime more than 90% of the space heating requirements with solar energy and it is the first large-scale solar district heating system (nominal capacity higher than 700 kW_{th}) operating in an extremely cold climate (HDD>5000).

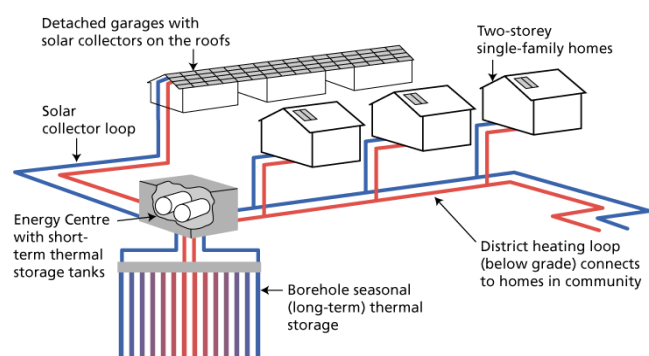

Figure 1 Picture of the Drake Landing Community and scheme of the solar district heating system [1].

Table 1 Project information

General information	
Country	Canada
City	Okotoks, Province of Alberta
Heating degree days ¹	5200
Specific information	
Project initiator /leader	CanmetENERGY, others (see 0)
Year of construction	2005-2007
Site area [ha]	2.95
Building units (residential)	52
Building units (tertiary)	1 (service building)
Heated area [m ²]	~7650

¹ (base temperature: 18°C)

Technical description

Heat demand

The 52 houses are single-detached homes with rear garages and breezeways. They are built from six distinct two-story home designs, ranging from 139 m² to 155 m², in size. These designs are similar to other new homes across Canada, except for the equipment connected to the solar thermal installations and the low-temperature district heating network. Moreover, they were certified to Natural Resources Canada’s R-2000 Standard for energy efficiency and, among other requirements, they had to be 30% more efficient than conventionally newly-built houses.

Building installations

Space heating installations

An integrated air handler and heat recovery unit, incorporating fans with electronically commutated motors and a water-to-air heat exchanger, supplies forced-air heating and fresh air. The unit adapts the conventional North American, air-based space heating systems for single-family houses to the requirements of the low-temperature district heating supply, which replaces the standard gas-fired furnace, from the functioning point of view. The indoor temperature is regulated by a conventional thermostat. The thermostat regulates the opening of an automatic valve that allows hot water to flow from the district heating loop through the heat exchanger in the air-handler unit. The heat transfer area of heat exchanger is larger than in conventional units. A fan blows air across the hot coil, heating the air and distributing it throughout the home in high volume, low velocity ductwork, similarly to conventional systems. The heat recovery ventilator exhausts warm, moist, stale air from within the home's wet rooms to the outside, and preheats cool, fresh incoming air.

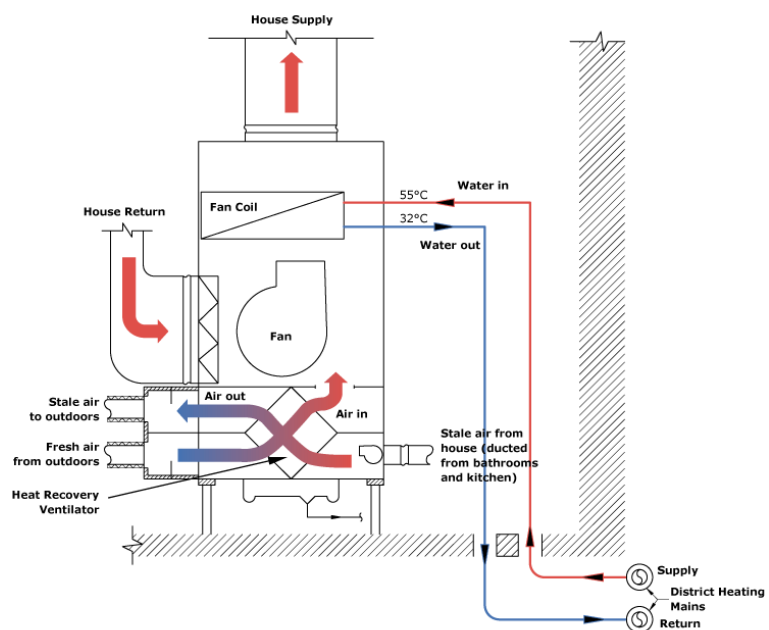

Figure 2 Picture and scheme of the low-temperature air-handling unit [1].

Annex X Final Report: Toward 4th Generation District Heating

Domestic hot water installations

Stand-alone solar domestic hot water systems installed on every house are designed to supply 50% to 60% of the annual energy demand for water heating. These systems include two self-regulating solar collectors mounted on the roof of each house. Solar energy is captured and transferred to a propylene glycol solution that circulates in a closed loop to a heat exchanger coupled to a solar hot water storage tank in the basement. Each stand-alone system is connected and backed-up with a high-efficiency gas-fired storage water heater that operates as needed to meet the water heating demands of the house.

Domestic hot water distribution

The in-house service pipes for domestic hot water were designed for the following loads: showers: 7.5 L/min; bathroom faucets: 4L/min; kitchen faucets: 6 L/min. All hot water pipes were insulated. Larger homes where the distance from the hot water tank to the furthest hot water tap exceeds 11 m were required to have a recirculation pump.

Heat distribution network

The solar heat absorbed by the flat-plate collectors, mounted on the roofs of the detached garages, is stored in soil underground and later is extracted and distributed through a district heating system to each home in the subdivision, when needed for space heating. Space heating is supplied to the 52 energy-efficient, detached houses through 4 parallel branches of a 2-pipe district heating system. Plastic, insulated, underground pipe is used to distribute heated water from the community's Energy Centre back to the homes. The hot water circulating through the plastic media pipes is typically between 40-50°C. These low operating temperatures match the requirements of reduced heat losses from the pipes and a large annual solar fraction.

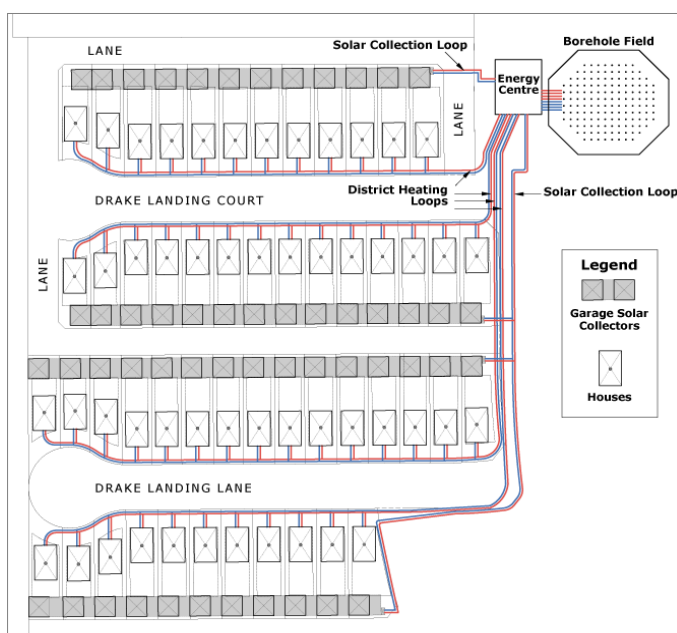

Figure 3 Scheme of the district heating and solar collector lines.

Annex X Final Report: Toward 4th Generation District Heating

The Energy Centre

The 230 m² energy centre building is located in the corner of the community park and it houses the Short-Term Thermal Storage (STTS) tanks and most of the mechanical equipment such as pumps, heat exchangers, and controls. The solar collector loop, the district heating loop, and the Borehole Thermal Energy Storage (BTES) loop pass through the energy centre. Approximately 70 % of the floor space is filled with two large, horizontal, insulated water tanks, each 3.7 m in diameter and 11 m long (combined water volume of 240 m³). The STTS acts as a buffer between the collector loop, the district loop, and the BTES field, accepting and dispensing thermal energy as required. The STTS tanks are critical to the proper operation of the system, because they can accept and dispense heat at a much higher rate than the BTES storage which, in contrast, has a much higher capacity. During periods of intense summer sunshine, the BTES field cannot accept energy as quickly as it can be collected; thus heat is temporarily stored in the STTS tanks, with transfer to the BTES continuing through the night. This situation is reversed in the winter, when heat cannot be extracted from the BTES field quickly enough to meet peak heat demands, typically in the early morning hours. Variable speed drives are employed to power the collector loop and district heating loop pumps to minimize electrical energy consumption while handling a wide range of thermal power levels.

Borehole Thermal Energy Storage (BTES)

A borehole thermal energy storage (BTES) system is an underground structure for seasonal heat storage. A BTES consists of an array of boreholes resembling standard drilled wells. After drilling, a plastic pipe with a “U” bend at the bottom is inserted down the borehole. To provide good thermal contact with the surrounding soil, the borehole is then filled with a high thermal conductivity grouting material (40 mm grout tube: 9% blast furnace cement, 9% Portland cement, 32% fine silica sand, 50% water).

The BTES consists of 144 boreholes, each stretching to a depth of 35 meters and planned in a grid with 2.25 meters between them. The BTES field covers 35 metres in diameter. At the surface, the U-pipes are joined together in groups of six that radiate from the centre to the outer edge, and then connect back to the energy centre building. The entire BTES field is then covered in a layer of insulation and then soil – with a landscaped park built on top. When solar heated water is available to be stored, it is pumped into the centre of the BTES field and through the U-pipe series. Heat is transferred to the surrounding soil and rock, and the water gradually cools as it reaches the outer edge and returns to the energy centre. Conversely, when the houses require heat, cooler water is pumped into the edges of the BTES field and as the water flows to the centre it absorbs heat. The heated water passes to the short-term storage tank in the energy centre and is then circulated to the house through the district heating loop. It was calculated that it will take approximately three years to fully charge the BTES field at a max. temperature of 80°C by the end of summer, achieving a solar annual fraction of approx. 90%.

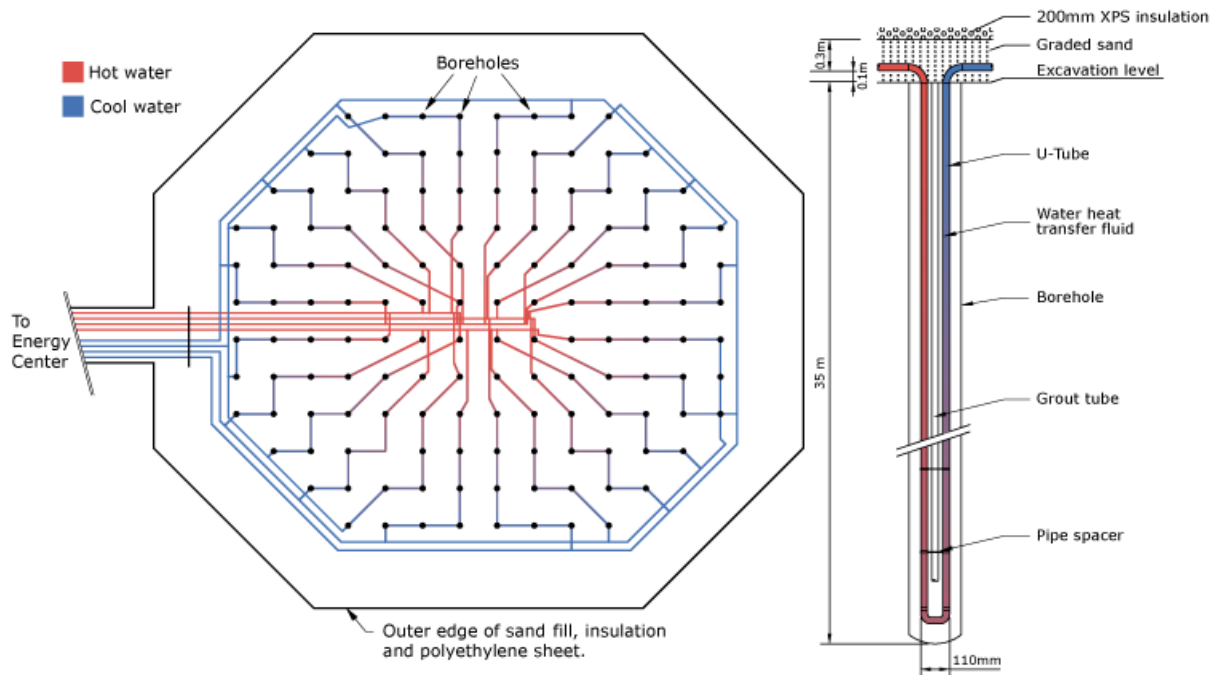

Figure 4 Aerial view of the BTES (left) and side view of a single borehole tube (right) [1].

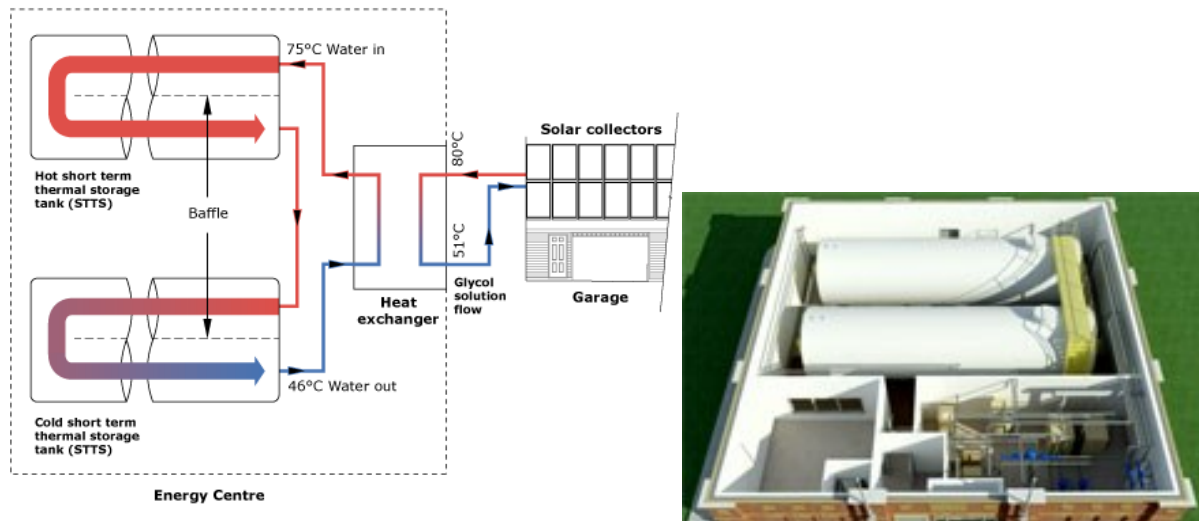

Figure 5 Picture of the Stratified Short Term Thermal Storage (STTS) Tanks and scheme of the solar collector loop [1].

Heat sources

The solar thermal collection system consists of 798 flat plate solar panels (total gross area: 2,293 m²) organized into four rows mounted on the detached garages. The collectors are connected via an underground, insulated pipe that carries the water-glycol solution to the community energy centre, where the heat is transferred through a heat exchanger to 2 short-term storage water tanks. The flow rate through the collectors is constant, whilst the flow rate on the water side of the heat exchanger is automatically adjustable.

Annex X Final Report: Toward 4th Generation District Heating

Planning principles and implementation strategies

Applied energy models/tools

Control strategy

Thermal stratification is important in both the BTES and the STTS to allow the high temperature water to be available for space heating needs while making relatively low temperature glycol available to supply the collectors. Both glycol and water collector loops utilize variable speed pumping. The control system was designed to vary the flow rate to achieve a 15°C temperature rise in the glycol loop and the water side pump would mimic the glycol side flow rate. This strategy enhances stratification in the STTS while reducing pump electricity consumption. The supply water temperature in the district heating network is varied linearly from 37°C for ambient air temperatures of -2.5°C or above to 55°C for ambient air at -40°C. Variable water flow rates are also used in the district heating circuit.

System design and simulation

During the project design phase, a model in the software TRNSYS was developed to simulate the system including the solar thermal collectors, the short term storage, the seasonal storage and the district heating system, the piping and controls. The house heating loads were predicted using detailed building energy simulations with the software ESP-r.

Tools used for energy monitoring

The complete solar system began operation during summer 2007 and its performance has been monitored since then using an automated control and data acquisition system.

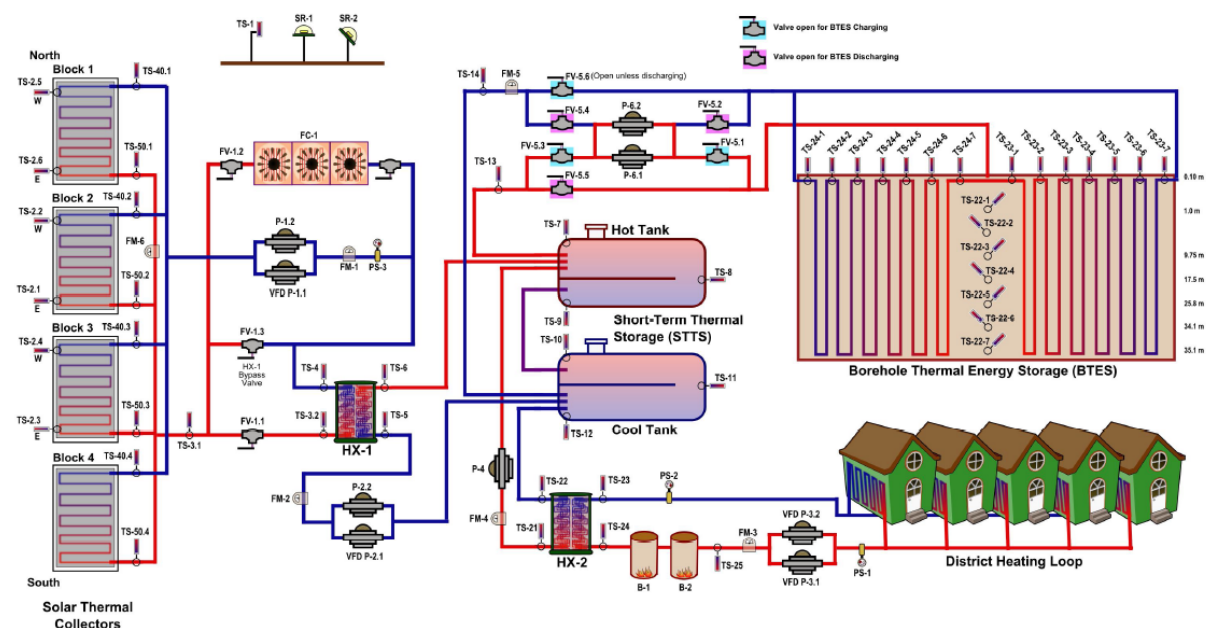

Figure 6 Functional System Schematic [2].

Annex X Final Report: Toward 4th Generation District Heating

Table 2 Main performance characteristics. Source: [2.]

Year of Operation (July 1-June 30)	2007-2008	2008-2009	2009-2010	2010-2011
Heating Degree-Days	5060	5230	4890	5480
Horizontal Global Irradiation [GJ/m ²]	4.63	4.96	4.65	4.58
Incident Global Irradiation [GJ/m ²]	5.82	6.07	5.49	5.45
Collected Solar Energy [GJ]	4470	4580	4270	4060
Collector Efficiency [*]	0.34	0.33	0.34	0.33
STTS Efficiency	0.96	0.91	0.95	0.93
Energy into BTES [GJ]	2610	2810	2500	2260
BTES Efficiency	0.06	0.2	0.35	0.54
Avg. BTES Core Temperature [°C]	38.7	50	54.1	52.2
Solar Energy to District Loop [GJ]	1670	1790	2030	2460
Total Energy to District Loop [GJ]	3040	2960	2550	2860
Solar Fraction	0.55	0.6	0.8	0.86
District Heating Heat Loss[GJ]	235	385	142	141

^{*}Based on gross collector area.

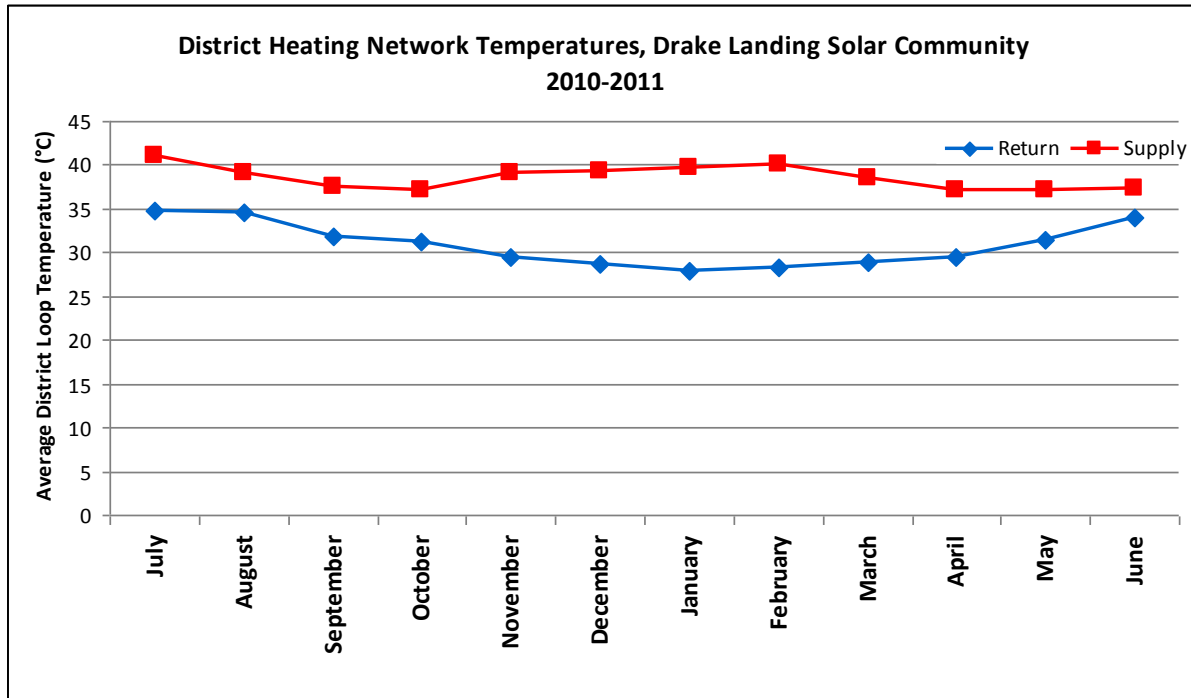

Figure 7. Average operating temperatures

Cost figures

Investment costs are listed below, for the main components of the system. If annual operating and maintenance costs and an allowance for future replacement of most of the collectors is added, the unit cost of solar energy delivered over 40 years was estimated to be approximately 0.17 CAD \$/kWh. Funding partners are listed in 0.

Table 3 Investment costs. Source: [2].

Item	Cost [CAD\$]
Solar Collectors Purchase	710,000
Installation	430,000
Seasonal Storage Borehole Field	620,000
District Heating & Solar Collection Circuits	1,025,000
Energy Centre including STTS Tanks	600,000
Total	3,385,000

* In the period 2005-2007

Table 4. Summary of system operating parameters, Drake Landing Solar Community, Okotoks, Canada

Quantity	Unit	Value ⁴
Trench length, L	m	1045
Annually sold heat, Q _s	GJ/a	2564
Linear heat density, Q _s /L	GJ/ma	2.42
Average pipe diameter d _a ¹	m	0.043
Thermal conductivity of pipe insulation, k	W/(mK)	0.023
Average supply temperature, T _S	°C	39.9
Average return temperature, T _R	°C	31.9
Average ambient temperature, T _A	°C	3.9
Average supply temperature (heating season), T _{S,hs} ²	°C	39.6
Average return temperature (heating season), T _{R,hs} ²	°C	29.2
Average ambient temperature (heating season), T _{A,hs} ²	°C	-4.2
Average supply temperature (non-heating season), T _{S,nhs} ³	°C	40.2
Average return temperature (non-heating season), T _{R,nhs} ³	°C	34.5
Average ambient temperature (non-heating season), T _{A,nhs} ³	°C	12.0

¹Distribution network, includes service lines to homes

²1st November – 30th April

³1st May – 31st October

⁴Measured values based upon 2-year average (July 2009-June 2011)

SWOT Analysis

Annex X Final Report: Toward 4th Generation District Heating

	Helpful to achieving the objective	Harmful to achieving the objective
Internal origin	<p><i>Strength</i></p> <ul style="list-style-type: none"> - Monitoring of the system made successive adjustments and improvements possible - Design based on advanced energy models - Annual solar fraction above 80-90% - Having individual solar domestic hot water systems in each home eliminates potential Legionella issues of operating the low temperature DES 	<p><i>Weakness</i></p> <ul style="list-style-type: none"> - Required substantial public funding grants at this scale - DES and individual DHW heating systems require back-up natural gas fired boilers
External origin	<p><i>Opportunities</i></p> <p>The improvement in the system performance during the years is due to modifications to the system and controls whose sub-optimal functioning was recognized by the monitoring system.</p>	<p><i>Threats</i></p> <ul style="list-style-type: none"> - Proper control and integration of the different sub-system is necessary

References

www.dlsc.ca (July 2012)

Sibbitt, B, McClenahan, D, Djebbar, R, Thornton, J, Bill Wong, B, Carriere, J, Kokko, J. Measured and simulated performance of a high solar fraction district heating system with seasonal storage. Available at 0.

www.oeo.nrcan.gc.ca (July 2012)

Appendix 6. Geothermal Low-Temperature District Heating (DH) System in Kirşehir, Turkey

General description

Project background and objectives

General information	
Country	Turkey
City	Kirşehir
Heating degree days	3044 ¹⁴
Specific information	
Project initiator /leader	The Governorship has the main share in the property of the DH company, while the Municipality is the co-owner.
Year of construction/energy renovation	March 1994 – supply to 400 dwellings February 1995 – supply to 1800 dwellings
Building units (residential)	1,800 standard dwellings in high-rise multi-family buildings (1 standard dwelling = 100 m ²)
Heated area [m ²]	180,000 ¹⁵

Availability of low-temperature (approx. 57°C) geothermal sources in the region close to the Turkish city of Kirşehir encouraged the local authority to establish a low-temperature DH system. Earlier investigations carried out at the existing in-house heating systems showed that low-temperature supply could satisfy the heating demand of the houses, since the existing in-houses heating systems were found to be over-dimensioned, up to three times larger than required. Hence, low-energy DH system was considered to be established with a design supply temperature from the geothermal reservoir of 57°C; no renovation was applied at in-house heating systems or at the building envelope. There was skepticism during the planning and design stage about the feasibility of the low-temperature DH system and the practicability of using low-temperature operation in such a cold climate, where the design outdoor temperature is -12°C (the same value used at higher latitudes such as in Denmark). Nevertheless, the low-temperature DH system has been in-operation since the year 1994 without any complaints from the consumers, for the 10-year operation period documented [1].

¹⁴ Data from [2].

¹⁵ Based on the information given in [1] and engineering practice in Turkey, the heated area of the reference house is 100 m². The DH system was dimensioned for 1800 reference houses.



Figure 7 The plate heat exchangers used at Kırşehir DH system [1].

Technical description

Heat demand

The main design parameter considered while dimensioning the low-temperature DH system was a total peak heat load of 16,740 kW, equivalent to 0.093 kW_{th}/m².

Building installations

Each in-house system is based on the control philosophy of “priority of domestic hot water heating”, which envisages that the supply of heat to the space heating system is stopped when domestic hot water is tapped. In fact, the thermal comfort conditions were considered not be jeopardized by the lack of space heating supply during the periods of domestic hot water use, whose duration was assumed to not exceed 10-15 minutes.

Space heating installations

The space heating emission system is based on radiators. The radiators installed at each house operate, on a yearly basis, with an average supply temperature of 53-54°C and an average return temperature of 40-41°C.

Domestic hot water installations

Two concepts were investigated during the preliminary design of the domestic hot water system. The first one envisaged the use of the water flow from the return line of the space heating system for pre-heating the domestic hot water, since the return temperature is at relatively high temperature level, approx. 40°C. The second concept is based on the aforementioned “priority of domestic hot water heating”. The latter was chosen because the economic advantages in terms of network pipe sizes, i.e. smaller media pipe diameters thanks to lower design peak loads, and savings in the in-house equipment were assessed more decisive in comparison to heat savings, the improved cooling of the district heating supply water and the consequent better exploitation of the geothermal reservoir.

The preparation of domestic hot water is ensured by instantaneous heat exchanger units –with heat transfer area in the range of 3–38.2 m², depending on the energy transfer unit type. During test measurements, for the design flows, the temperature of the domestic hot water was found to be 48°C, when the temperature of the cold water at the end-user’s side was 15°C.

Heat distribution network

The DH network consists of two pipeline circuits: the primary geothermal circulation line and the secondary distribution network, with energy transfer units based on plate heat exchangers at the interface between the two circuits. The re-injection pipes and some parts of the distribution network return pipes are not insulated, since the extra-insulation would not have been an economical investment, due to the extremely low heat price.

Table 4 *Yearly-averaged operating temperatures of the primary and secondary network.*

	Average Temperature [°C]
T_{supply} (Geothermal Line)	56 – 57
T_{return} (Geothermal Line)	38
T_{supply} (Distribution Network)	54
T_{return} (Distribution Network)	41

The distribution network consists of a pair of single pipes, either pipes of fiberglass-reinforced polyester or pre-insulated steel pipes, directly buried at 1.5–2.0 m below the ground surface, without concrete blocks. The temperature drop along the supply line was observed to be approx. 0.4°C/km and the distance between the geothermal wells and the furthest building in the settlement is 2 km. The operation of the pumping stations is controlled separately both in the geothermal loop and in the distribution network, in order to adjust the flow rate/pressure depending on the outside temperature and the minimum pressure levels required by the critical installations in the network. Each pumping station consists of three pumps. The first stage pump was chosen to satisfy the base load, equivalent to approx. 16% of the peak load and is the one that is used in the summer months too. In case the overall demand increases, the second stage pump was defined to be activated to satisfy the overall heat demand equivalent to 39% of the peak load. Then, the third stage pump was defined to be activated to satisfy the overall heat demand equivalent to 78% of the peak heat demand.

The second control philosophy of “increasing the supply temperature” was considered to be used if the overall heat demand could not be satisfied by use of three pumps in operation altogether. The supply temperature was considered to be increased to 61°C by means of oil boilers, during peak-load conditions.

Heat sources

The Kırşehir district heating system has two heat sources (W-1 and W-2) of low-temperature geothermal heat, which are shown in the table below. The distance between these two wells is around 100 m. In addition to those, there is a third well, named W-3, situated at 400-meter

Annex X Final Report: Toward 4th Generation District Heating

distance from the heat extraction wells, and used for re-injection of the geothermal water from the return pipeline.

The geothermal wells for heat extraction in Kirşehir.

Well	Depth [m]	Source Temperature [°C]	Mass Flow Capacity [kg/s]	Establishment Year
W-1	274	57	110	1991
W-2	280	57	185	1993

Two oil boilers were designed to be used to increase the supply temperature to approx. 61°C during peak load conditions. The total heating power of the boilers is 5.8 MW (2 x 2.9 MW). The operation of the secondary distribution network with supply/return temperatures of 54/41°C satisfied 78% of the annual heat demand while the remaining part is provided with a supply temperature of 61°C.

Planning principles and implementation strategies

Cost figures / Financial set-up / Incentives

The investment cost was approx. 2 million USD resulting in 1350 \$/dwelling, including engineering costs and installation. The heat price for the final consumers was equivalent to 0.65 c\$/kWh in the year 2000.

SWOT Analysis

	Helpful to achieving the objective	Harmful to achieving the objective
Internal origin	<p><i>Strengths</i></p> <ul style="list-style-type: none"> - Abundance of geothermal reservoirs at relatively low depth. - No need to change the in-house space heating system 	<p><i>Weakness</i></p> <ul style="list-style-type: none"> - Relatively-high initial investment. The consumers had to pay an initial cost equivalent to almost half of the investment.

External origin	<p><i>Opportunities</i></p> <ul style="list-style-type: none"> - Security of energy supply, thanks to the use of locally-available heat sources - Use of a fully renewable heat source - Fibreglass-reinforced polyester and pre-insulated steel pipes, thanks to the low, constant operating temperatures, do not require expansion joints, as the expansion strength due to thermal stress remains below the pipe mechanical resistance. 	<p><i>Threats</i></p> <ul style="list-style-type: none"> - High-level expertise and know-how is required
-----------------	---	---

Conclusions and lessons learnt

The low-temperature DH system operating in the Turkish city of Kirşehir since 1994 is a unique example of how low-temperature systems based on renewable energy could be applied even in existing buildings with their existing in-house space heating systems. Geothermal district heating systems have an important meaning to the Turkish citizens who make use of these systems, since a clean environment and comfort has been provided to residences in a cost-effective way. According to the experiences so far and the situation in Turkey, the investments in geothermal district heating have a pay-back time of 5–8 years. They are characterized by a low heat cost in comparison to conventional fuels such as coal, lignite and fuel-oil or imported natural gas: for example, the price of the unit of geothermal energy is between 4 times and 7 times lower of heating with natural gas in Turkey [7].

Acknowledgements

This document is based on the information contained in [1], [4]-[7]. Mr. Hakan Tol from Technical University of Denmark is acknowledge for his help in preparing the document and translating documents from Turkish.

References

- [1] O. Mertoğlu. Geothermal Applications in Turkey. Antalya, Turkey : s.n., 2005. Proceedings World Geothermal Congress, 1-5.
- [2] Turkish State Meteorological Service. Heating and Cooling Degree Days [in Turkish]. Available at www.dmi.gov.tr (January 2012)
- [3] M. Foged. Low temperature operation. 1999, DBDH, 4-9.
- [4] O. Mertoğlu, N. Bakır, T. Kaya. Geothermal Applications in Turkey. 2003, Geothermics, 419-28.

Annex X Final Report: Toward 4th Generation District Heating

- [5] O. Mertođlu, et al. Alternative Energy Sources and Low-Temperature Geothermal District Heating Systems [in Turkish]. 1999, TESKON, 917-29.
- [6] O. Mertoglu, A. Canlan, N. Bakir, I. Dokuz, T. Kaya. Geothermal direct use applications in turkey: technology and economics. Proceedings of the World Geothermal Congress, Kyushu-Tohoku, Japan.
- [7] K. Kaygusuz, A. Kaygusuz. Geothermal energy in Turkey: the sustainable future. Renewable and Sustainable Energy Reviews, 2004;8:545-563.

Appendix 7. Low-temperature district heating network for newly-built Zero Carbon Housing Development - Greenwatt Way – in Slough, United Kingdom

General description

Project background and objectives

In 2006 the UK Government announced that new housing constructed from 2016 onwards would be 'Zero Carbon'. The Greenwatt Way houses were built to demonstrate if the 'Zero Carbon' home standard was achievable with a range of renewable heat sources. It was decided to see if this could be achieved via a district heating scheme rather than having individual renewable heating systems for each house. To ensure efficient performance of the heat pumps it was essential to operating the DH and house heating systems at the lowest possible temperatures.

'Zero Carbon' is demonstrated through achievement of Level 6 of the Code for Sustainable Homes (CfSH). CfSH encompasses not only energy efficiency but also other environmental factors such as water conservation, ecology and material selection. The energy element of the CfSH is calculated through the Standard Assessment Procedure (SAP). SAP, based on design data, encompasses all domestic heat consumption and a limited proportion of the electricity consumption. The 'Zero Carbon' definition did include for all household electricity demand at the time these house were certified but this has now changed only include the SAP estimated electricity which is for lighting, pumps and ventilation fans only.

Once the houses were occupied the objective of the project was to verify in practice the actual energy performance of houses, DH and renewable heat generation technologies. Monitoring, on a 5 minutely basis for 2 years was done to measure the performance and the demand patterns.

Table 13. General information about the newly-built Zero Carbon Housing Development Greenwatt Way – in Slough, United Kingdom

General information	
Country	UK
City	Slough
Heating degree days ¹	3191
Specific information	
Project initiator /leader	Scottish and Southern Energy
Year of construction/energy renovation	2010
Site area[ha]	0.18
Building units (residential)	10
Number of residents	25
Building units (tertiary)	1
Heated area	845
Plot ratio ²	0.47

¹ Base temperature: 20°C, Thames Valley region, 2007-2011

² built floor area/site area

Images

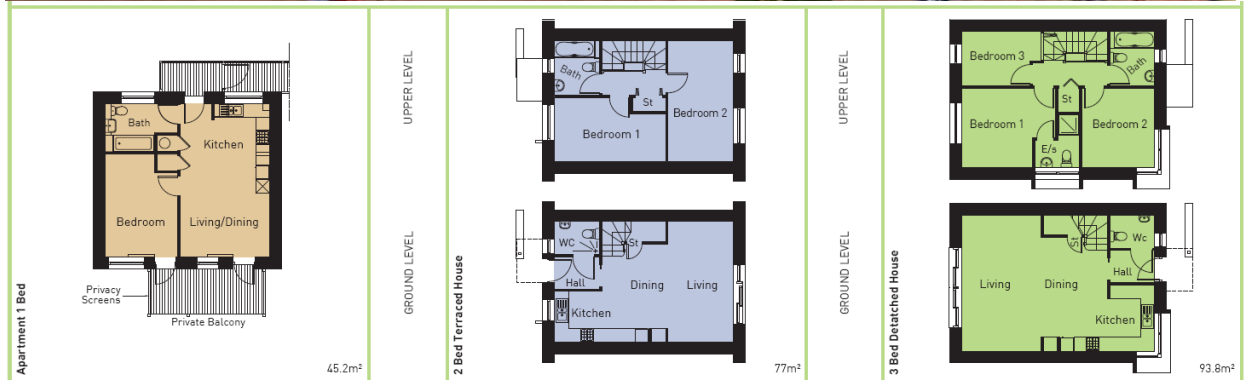

Technical description

Heat demand

Peak power [kW]*	34 (measured)
Total heat demand [GJ/yr]**	180 (measured)
Total heat demand [MWh/yr]**	50 (measured)
Specific heat demand (residential)	
Specific space heating demand [kWh _{th} /m ²]	27 (derived)
Specific domestic hot water demand [kWh _{th} /m ²]	15 (measured)
Total [kWh _{th} /m ²]	42 (measured)

*Average hourly. Based on heat supplied from energy centre.

** Based on heat supplied to houses.

Building

The site consists of ten dwellings; two 1 bed apartments (45 m² each), a terrace of three 2 bed houses (80 m² each), a terrace of three 3 bed houses and two 3 bed detached houses (94 m² each). There is also the Energy Centre and a meeting room.

Four houses are built from timber frame panels manufactured offsite with the remaining buildings constructed in masonry block. Both types of construction are typical for the UK but had to be insulated to a much higher standard as to meet achieve CfSH Level 6. The heat loss parameter (HLP) must be less than 0.8 W/m²K, to achieve this the U-value for floors and roof is 0.10 W/m²K, walls 0.12 W/m²K and windows 0.78 W/m²K and a Mechanical Ventilation Heat Recovery (MVHR) unit is fitted in each house. The MHVR along with a high level of air tightness helps achieve the required HLP standard.

District Heating Scheme

The district heat (DH) for space heating and domestic hot water is provided from the site's Energy Centre. The DH scheme is built with a mix of steel and Aluflex pre-insulated twin pipe to minimize heat losses. The district heating scheme operates at a flow temperature of 55°C. The energy centre has both ground and air source heat pumps and a biomass boiler. In addition there is 20m² of evacuated tube solar thermal. Control of the energy centre is via a Trend 963 BMS.

Space heating installations

Each house is equipped with directly connected substation, the space heating distribution system consists of single large radiator in the open plan lounge/kitchen and towel rails in bathrooms. Additionally a heater battery is installed on supply ventilation after the MVHR unit, which is connected in series after the radiators. The radiators have pre-settable TRV which ensures the design flow rates for the radiators, to achieve 55/35C, are not exceeded. The heater battery then cools the DH further, the level of cooling dependent upon external air temperature giving a final return temperature from the space heating of between 25-30°C. The measured space heating demands are significantly higher than the SAP design estimates. We believe a major part of this may be due to the installation of the MVHR unit and some long

Annex X Final Report: Toward 4th Generation District Heating

length of duct in the attic, outside the insulated envelope of the house. SAP makes no allowance for the additional heat losses arising from this.

Domestic hot water installations

Domestic hot water (DHW) is supplied at 43°C via an on-demand heat exchanger within the substation. The temperature control is achieved by the Samson thermostatic control valve being driven from the gas space sealed on the end plate of the HX. Operating at 55°C is below the specified control range of this valve. The 43°C DHW set point is low but increasing the temperature differential between the DHW setpoint and the DH flow temperature assists the valve to operate. The low DHW setpoint also ensures the control valve will close if the DH flow temperature drops. The measured DHW demand is very close to the SAP estimate.

There are separate heat meters in the substation for DHW and the space heating. This allows accurate monitoring and profiling of these loads individually.

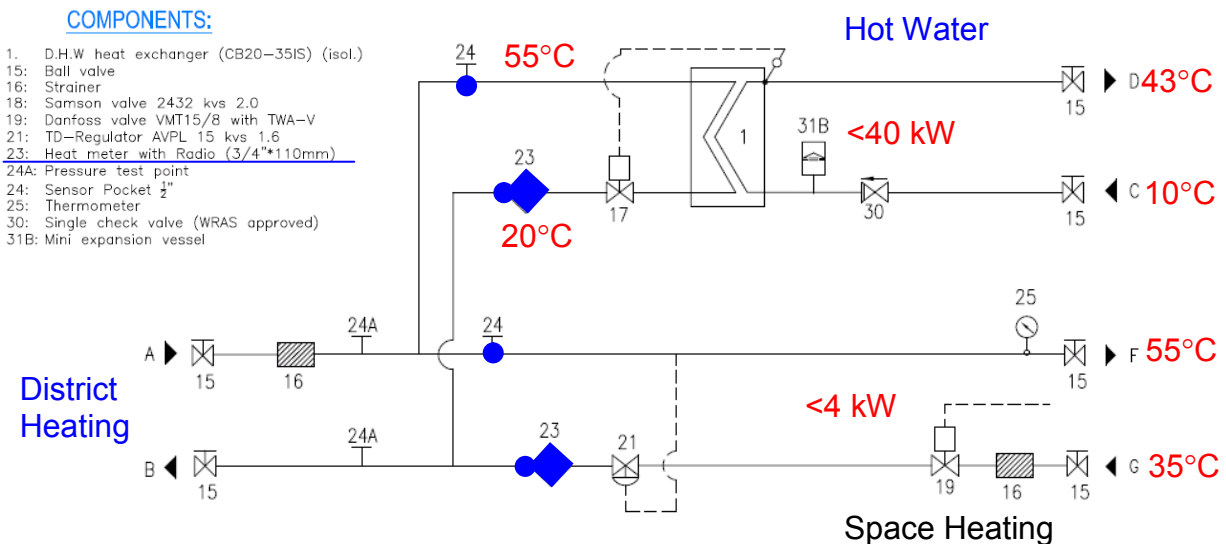

Domestic hot water distribution

The DHW systems in houses are built with plastic pipes of 22 mm diameter. The UK design standards are based on conservative assumption, like most of the taps being on simultaneously at high flowrates and assume the lowest of supply pressure. Additionally the CfSH requires flow restriction on most taps to conserve water but pipe sizing standards do not account for this. This leads to the use of 22 and 15mm pipe and the contractor was of the belief that oversizing the pipes was a positive thing – so much of what could have been 15mm (or smaller) pipe was installed as 22mm. The end result is very slow DHW delivery times of over 30 seconds due to the low flow rates and large volumes in pipe.

Heat distribution network

Trench length [m]	165
Linear heat density [kWh/(m·yr)]	217
Average T_{supply} [°C] (heating season) ¹	51.7
Average T_{return} [°C] (heating season)	31.7
Average T_{supply} [°C] (non-heating season) ²	50.5
Average T_{return} [°C] (non-heating season)	38.1

¹ Measured between 1 October and 31 April

² Measured between 1 May and 30 September

The variation in DH flow temperature between winter and summer is not deliberate. The intention was to achieve 55°C at all times. The return temperature is high during the measured summer period due to a single poorly setup DHW control valve. The measured DH heat losses are close to the modeled value, but the above ground DH pipe had higher losses due to its lower standards of insulation. The monitored flow rates on DH show that the pipes are oversized and that hence heat losses could have been reduced through the use of smaller pipework.

Heat sources

Heat for the district heating scheme is generated in the integrated renewable Energy Centre. The centre consists of four renewable heating technologies:

- 30 kW biomass boiler with accompanying pellet storage silo,
- 2 x 17 kW ground source heat pumps (GSHP) with 7 boreholes of 100 m depth,
- 40 kW air source heat pump (ASHP),
- 20 m² evacuated tube solar thermal panels (STH),
- 8 m³ stratifying thermal store with multiple connections for staged heating of the store at different temperatures.

The area of solar thermal was limited by the need for sufficient roof space for PV to provide for the houses electrical demands. The design is such that all the heat demands could be supplied by either the GSHP, the ASHP or the biomass boiler in addition to the solar thermal. This was so each technology could be individually tested. The control system aims to optimise the system performance by staging the heat pump operation to maximise the heating of cooler lower parts of the store and so that on sunny days the limited solar thermal heats the top of the store whilst the heat pumps pre heat the bottom of the store. In operation the ASHP has achieved a COP of 2.1 and the GSHP a COP of 2.9– but there is still scope to improve the staged heating of the thermal store which will increase the proportion of heating done at lower temperatures.

Special R&D topics/issues

The research programme at GWW includes several work streams with an initial monitoring programme of two years and includes:

- Modelling and monitoring of the energy performance of the renewable energy centre, district heating scheme and domestic heat and power demand.
- Post occupancy evaluation of the tenants.

Annex X Final Report: Toward 4th Generation District Heating

- Evaluation of the whole house mechanical ventilation with heat recovery system (MVHR).
- Trial / evaluation of hot fill washing machine and dishwasher.
- Monitoring of water usage - mains and harvested rainwater.
- Monitoring of PV generation

Additional energetic aspects

(implemented measures reducing the heat demand, or targeting energy-efficiency heat generation and distribution, or RE exploitation; other...)

Planning principles and implementation strategies

Applied urban planning policies/instruments

The main driver of the GWW development was to explore the feasibility and practicality of the 2016 'Zero Carbon Homes' standard (Code for Sustainable Homes level 6). There were no local planning requirements necessitating the energy standards of this development. There was no requirement for DH.

Applied energy models/tools

The houses were modelled in IES. The energy centre plant in energyPRO. Thermal store simulation in Transys. The house energy consumption was also modelled in SAP – the UK assessment tool for demonstrating compliance with the section of the Building Regulations that details required energy standards (Part L). SAP tends to get used as an energy model – but it is really a tool to demonstrate compliance.

Tools used for energy monitoring

Separate heat meters on DHW and space heating loads of each house. Data logged at 5 minute intervals via the meter suppliers (Hydrometer) AMR system Half hourly metering on electricity (PV generation, import and export). All energy centre parameters logged at 5 minute intervals on Trend 963 BMS system. Monitoring of room temperatures and humidity's in houses.

Cost figures / Financial set-up / Incentives

Fully funded by SSE. Cost difficult to state due to accelerated development period, inclusion of monitoring kit, use of multiple heat sources in energy centre. The main incentive received is the feed in tariff for the large PV arrays on each house. The Renewable Heat Incentive could have been claimed for the renewable heat generation plant but the cost of required verification work was very high relative to the heat used and hence tariff value – particularly as SSE may not operate all of the renewable plant in the long run.

SWOT Analysis

	Helpful to achieving the objective	Harmful to achieving the objective
Internal origin	<p><i>Strength</i></p> <p>Low temperature DH operation worked well</p> <p>DH / energy centre designer / contractor met the challenge well.</p> <p>Radiators in series with heat battery in ventilation system was effective at bringing the DH return temperatures down</p>	<p><i>Weakness</i></p> <p>Complexity of control system for energy centre and thermal store.</p> <p>Comfort levels in the houses would have been improved if there had been a radiator in each room.</p> <p>DHW delivery times would be improved with use of smaller distribution pipe work.</p> <p>Locating the MVHR unit outside of the insulated envelope incurred large additional heat losses.</p>
External origin	<p><i>Opportunities</i></p> <p>Post construction analysis indicates that DH pipes could be reduced in size which would reduce capital costs and heat losses.</p> <p>Data from space heat and DHW monitoring will be very useful to improve the design of future low energy DH schemes</p>	<p><i>Threats</i></p> <p>Strict enforcement of the new UK Legionella regulations may have been difficult to implement.</p> <p>Weakening of the ‘Zero Carbon’ definition may make alternative non DH / non renewable heat approaches viable for future UK houses</p>

Conclusions and lessons learnt

Low temperature DH worked well all delivered good comfort to residents.

With monitored heat demand data we know the DH pipework is over sized and can be reduced in future projects.

In operation there have been few issues with low DHW temperature – use of a different substation design could have increased the DHW temperature.

Annex X Final Report: Toward 4th Generation District Heating

In operation there were no significant issues arising from direct connection of DH – although in the UK direct connection is commonly viewed as risky.

Low energy houses need radiators in each room to ensure even distribution of heat and control of individual room temperatures.

Placing MVHR in loft outside the building insulated envelope results in very high additional heat losses – but the UK regulations do not penalise this.